

RCAF "2 WING" MK6 SABRE

#72.18 1/72 SCALE

#48.13 1/48 SCALE

#32.07 1/32 SCALE

**Leading
Edge**
MODELS

High Quality Model Decal



421 "Red Indian"
Squadron

Decals provided to represent an F-86 of either
416, 421 or 430 Squadrons.



430 "Silver Falcon"
Squadron

RCAF SABRES
#2 FIGHTER WING
GROSTENQUIN, FRANCE
1953 - 1963

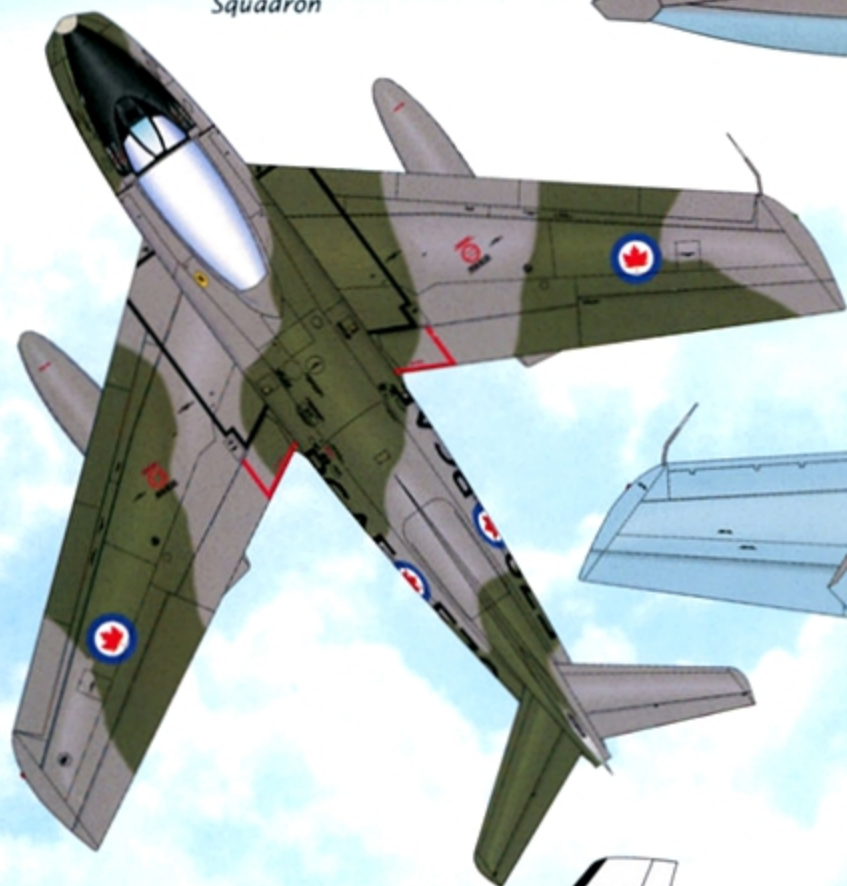

416 "Lynx"
Squadron



Dark Sea
Grey

Dark
Green

PRU
Blue

Reference Help:
 Tony Stachiw
 John Bradley

**RCAF "2 WING" MK6 SABRE
 OPTIONAL MARKINGS**

Sabre jocks:
 Ray Goeres 416
 John Ursulak 421
 John Ink 421
 C.J Simpson 421

Note:
 Position of roundel to airbrake varies.

416 Squadron

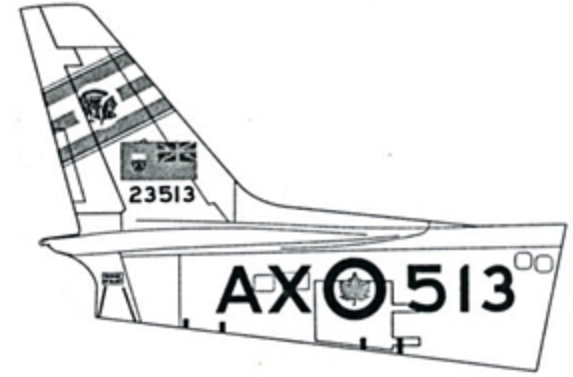
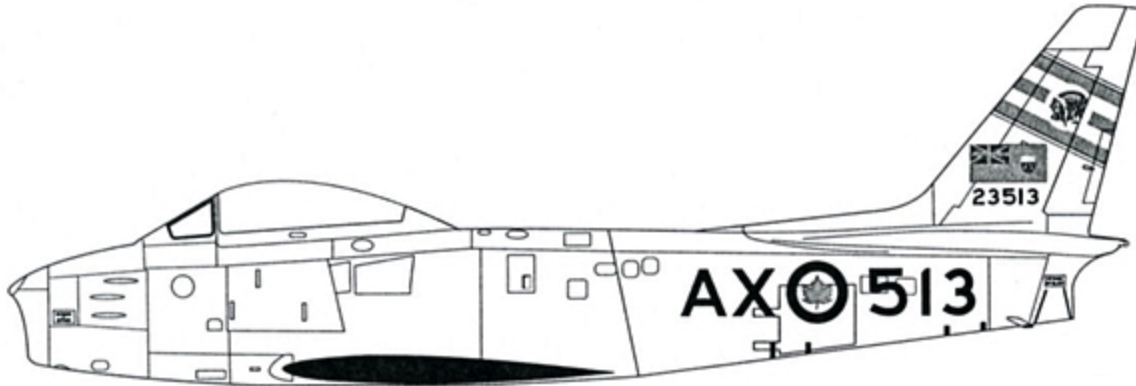
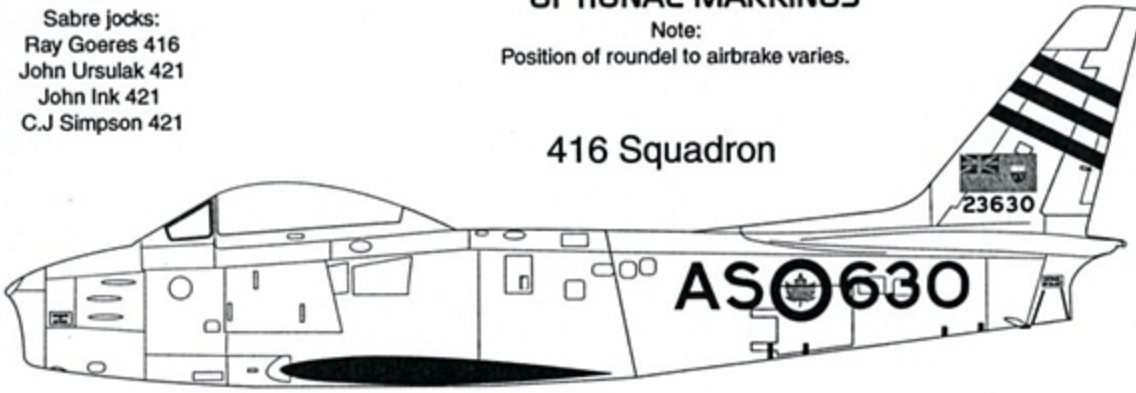

421 Squadron

Due to the variety of kits 1/72 & 1/48
 available, band is oversize
 to accommodate all kits.
 Trimming may be necessary.

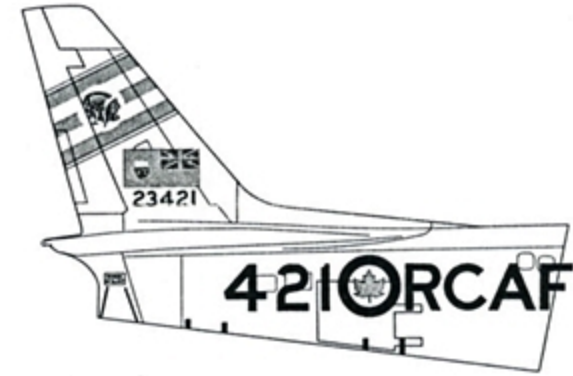
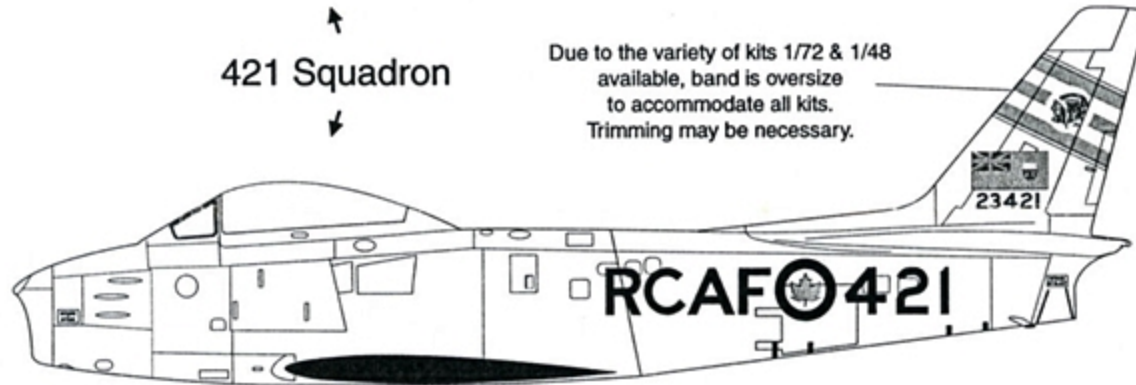

#586 markings may also be as #578 with "RCAF" as below.

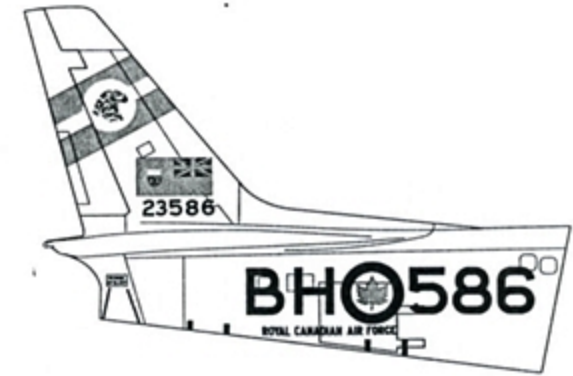

Smaller "Royal Canadian Air Force" decal.
 Larger lettering decals included not required
 for these options

430 Squadron

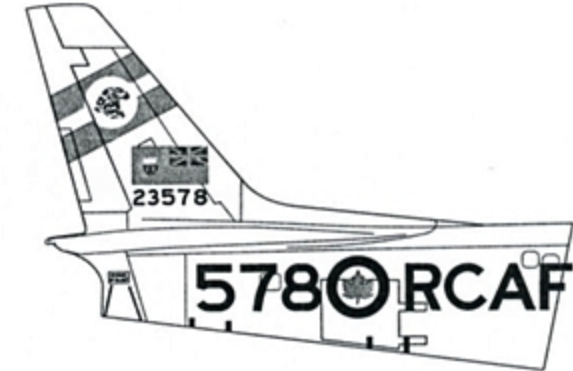

Note: You are modelling the best dog-fighting variant of all F-86s built. The Canadair Mk6, powered by the Orenda 14 engine with the slatted 6-3 wing no doubt ruled the skies over Western Europe in the mid and late 50's. The MK6 won all NATO air gunnery weapons competitions it participated in during the 1950's. The RCAF at it's height operated 12 Squadrons of Sabres in Europe.

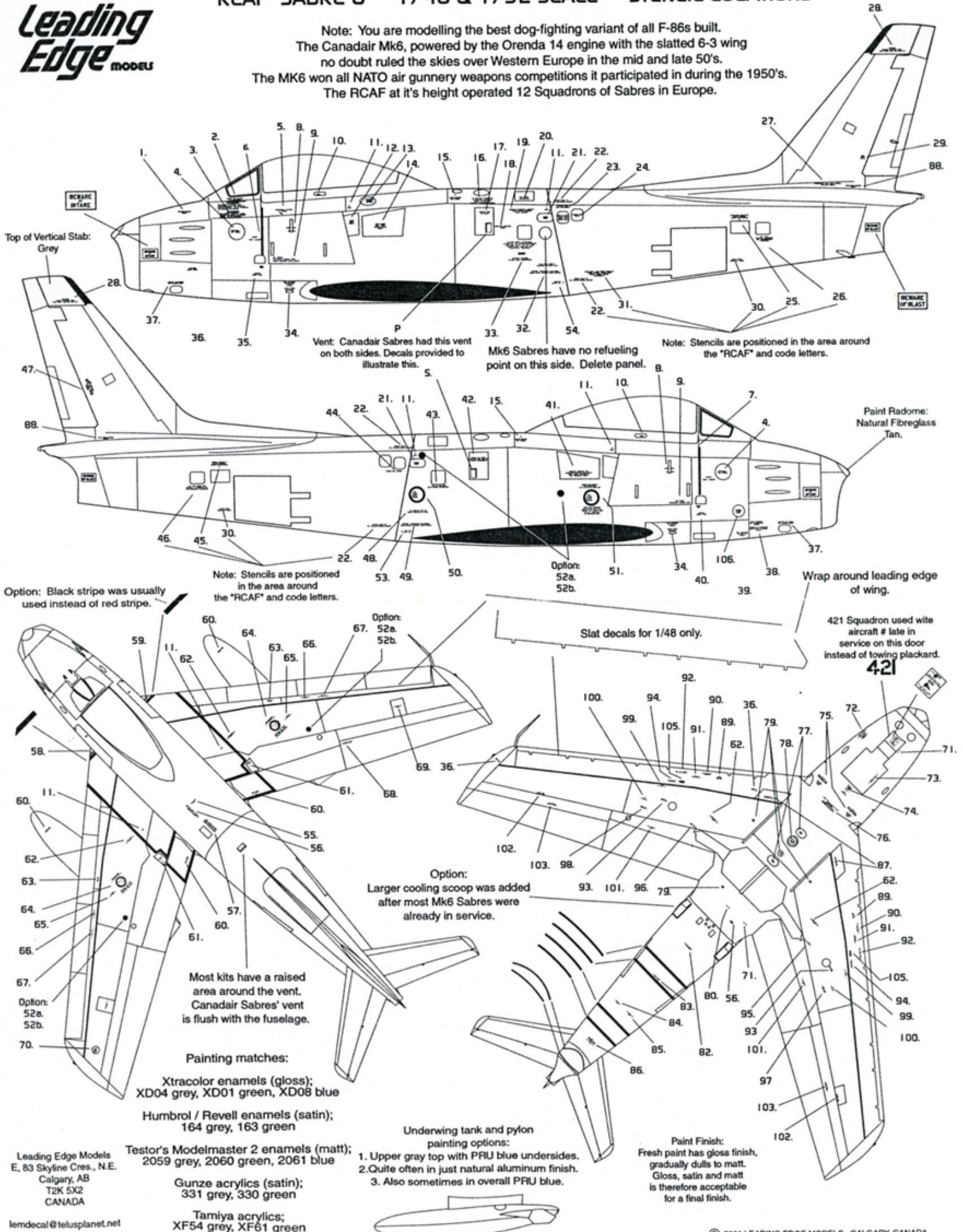

Top of Vertical Stab: Grey

REAR OF BLAST

Vent: Canadair Sabres had this vent on both sides. Decals provided to illustrate this.

Mk6 Sabres have no refueling point on this side. Delete panel.

Note: Stencils are positioned in the area around the "RCAF" and code letters.

Paint Radome: Natural Fibreglass Tan.

Option: Black stripe was usually used instead of red stripe.

Note: Stencils are positioned in the area around the "RCAF" and code letters.

Option: 52a, 52b

Wrap around leading edge of wing.

Slat decals for 1/48 only.

421 Squadron used wite aircraft # late in service on this door instead of towing placard.

421

Option: Larger cooling scoop was added after most Mk6 Sabres were already in service.

Most kits have a raised area around the vent. Canadair Sabres' vent is flush with the fuselage.

Painting matches:

Xtracolor enamels (gloss); XD04 grey, XD01 green, XD08 blue

Humbrol / Revell enamels (satin); 164 grey, 163 green

Testor's Modelmaster 2 enamels (matt); 2059 grey, 2060 green, 2061 blue

Gunze acrylics (satin); 331 grey, 330 green

Tamiya acrylics; XF54 grey, XF61 green

Underwing tank and pylon painting options:

1. Upper gray top with PRU blue undersides.
2. Quite often in just natural aluminum finish.
3. Also sometimes in overall PRU blue.

Paint Finish: Fresh paint has gloss finish, gradually dulls to matt. Gloss, satin and matt is therefore acceptable for a final finish.

Leading Edge Models
E, 83 Skyline Cres., N.E.
Calgary, AB
T2K 5X2
CANADA

lemdecals@telusplanet.net

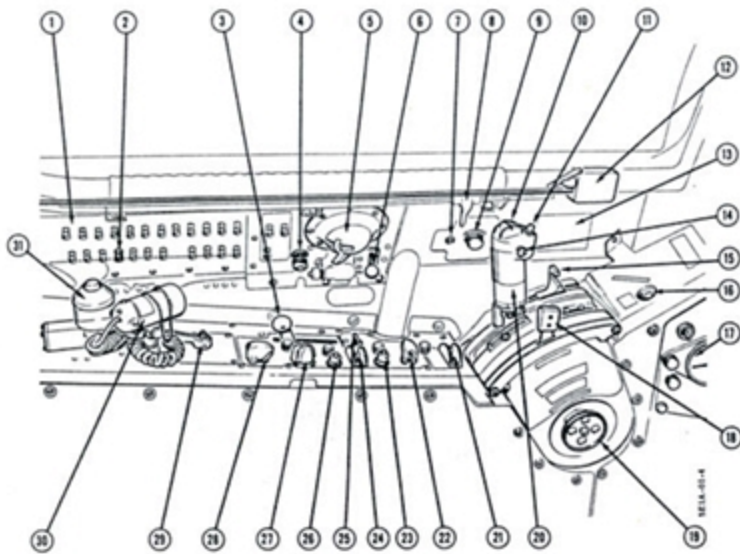

- | | |
|---|---|
| 1 Left circuit breaker panel. | 15 Jet pipe temperature limiter override tell tale. |
| 2 Landing gear control circuit breaker | 16 Bomb-rocket-tank jettison button. |
| 3 Cockpit air outlet selector. | 17 Oxygen regulator. |
| 4 Windshield anti-ice overheat warning light. | 18 Wing flap control. |
| 5 Cockpit sidewall air outlet. | 19 Throttle friction wheel. |
| 6 Windshield anti-ice control. | 20 Throttle control lever. |
| 7 Rocket release indicator dial. | 21 Flight control switch. |
| 8 Canopy and windshield auxiliary defrost control. | 22 Longitudinal alternate trim switch. |
| 9 Rocket release control. | 23 Rudder trim switch. |
| 10 Speed brake switch. | 24 Cockpit pressure control switch. |
| 11 Gunsight gyro caging button. | 25 Lateral alternate trim switch. |
| 12 Tow target emergency release. (Aircraft 23371 to 23430 inclusive.) | 26 Cockpit pressure schedule switch. |
| 13 Fuel specification placard. | 27 Cockpit temperature control rheostat. |
| 14 Microphone button. | 28 Cockpit temperature control switch. |
| | 29 Drop tank pressure shut-off lever. |
| | 30 Console floodlight. |
| | 31 Anti-G suit valve |

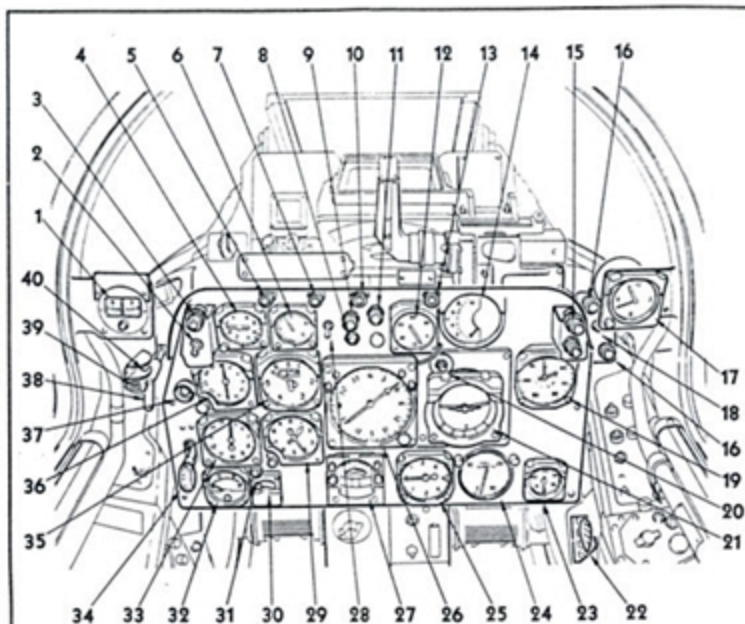

- | | | |
|---|--|---|
| 1 STANDBY MAGNETIC COMPASS | 13 TAKE-OFF TRIM POSITION INDICATOR LIGHT | 26 GYRO COMPASS |
| 2 EMERGENCY FUEL CONTROL SWITCH | 14 JET PIPE TEMPERATURE INDICATOR | 27 TURN AND BANK INDICATOR |
| 3 EMERGENCY FUEL CONTROL WARNING LIGHT | 15 DROP TANKS EMPTY WARNING LIGHTS | 28 HYDRAULIC PRESSURE GAUGE SELECTOR SWITCH |
| 4 ACCELEROMETER | 16 FIRE WARNING LIGHTS | 29 ALTITUDE METER |
| 5 MAIN INSTRUMENT INVERTER WARNING LIGHT | 17 CLOCK | 30 LOADMETER |
| 6 HYDRAULIC PRESSURE GAUGE | 18 FIRE WARNING LIGHT TEST BUTTON | 31 GENERATOR WARNING LIGHT |
| 7 BOTH INSTRUMENT INVERTERS WARNING LIGHT | 19 TACHOMETER | 32 MACHINETER |
| 8 GYRO COMPASS FAST SLAVING BUTTON | 20 ARTIFICIAL HORIZON FAST ERECTION BUTTON | 33 LANDING GEAR SELECTOR HANDLE |
| 9 FLIGHT CONTROL, ALTERNATE-ON LIGHT | 21 ARTIFICIAL HORIZON | 34 AIRSPEED INDICATOR |
| 10 MAIN RADAR INVERTER WARNING LIGHT | 22 ALTERNATE CANOPY JETTISON RELEASE | 35 RADIO COMPASS |
| 11 LOW FUEL PRESSURE WARNING LIGHT | 23 CABIN ALTITUDE | 36 LANDING GEAR EMERGENCY UP BUTTON |
| 12 OIL PRESSURE GAUGE | 24 FUEL QUANTITY GAUGE | 37 PARKING BRAKE HANDLE |
| | 25 VERTICAL SPEED INDICATOR | 38 TOW TARGET JETTISON SWITCH (ON AIRCRAFT 23371 TO 23430 INCLUSIVE.) |
| | | 39 CANOPY ACTUATING SWITCH |
| | | 40 |

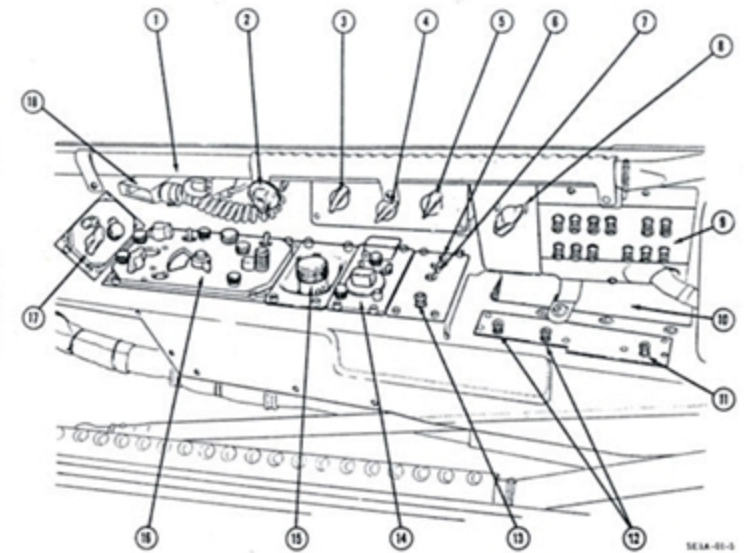

- | | |
|--|---|
| 1 Cockpit sidewall air outlet control. (behind console light). | 10 Map case. |
| 2 Console floodlight mount. | 11 Fire warning circuit breaker. |
| 3 Instrument panel primary light rheostat. | 12 Instrument inverter circuit breaker. |
| 4 Instrument panel auxiliary light rheostat. | 13 Ice detector circuit breaker. (Aircraft 23371 to 23490 inclusive.) |
| 5 Console and panel light control rheostat. | 14 IFF control panel. |
| 6 Air intake duct pitot heater switch. | 15 Gunsight test plug. |
| 7 Drop tanks empty lights switch. | 16 Radio compass control panel. |
| 8 N-9 camera lens aperture selector. | 17 VHF control panel. |
| 9 Right circuit breaker panel. | 18 Console floodlight. |

1/32 Wing Tip Conversion (from Hasegawa kit)

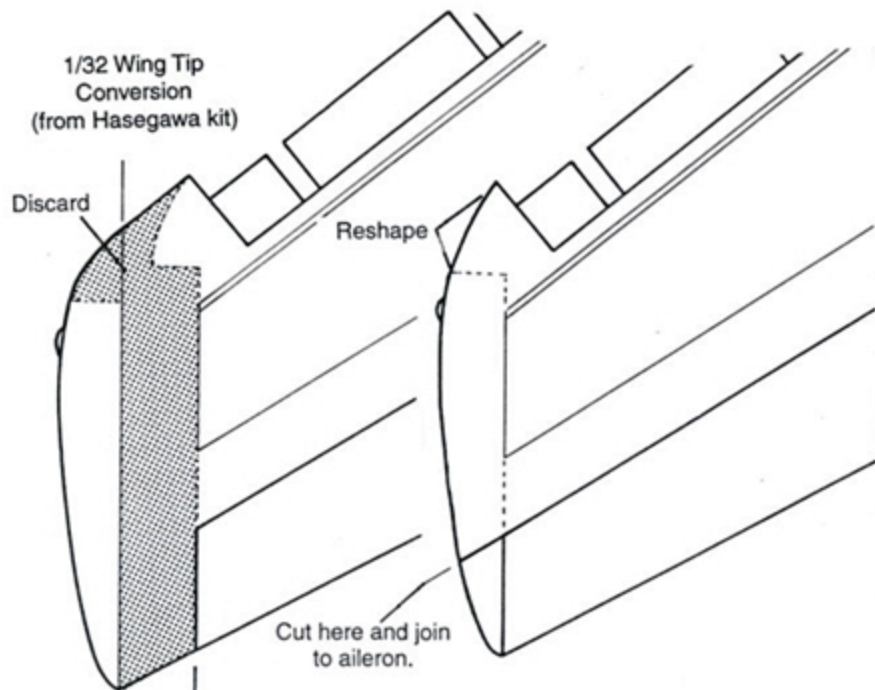

Cut along panel line.

Sabre Mk.6 pilot's manual illustrations.

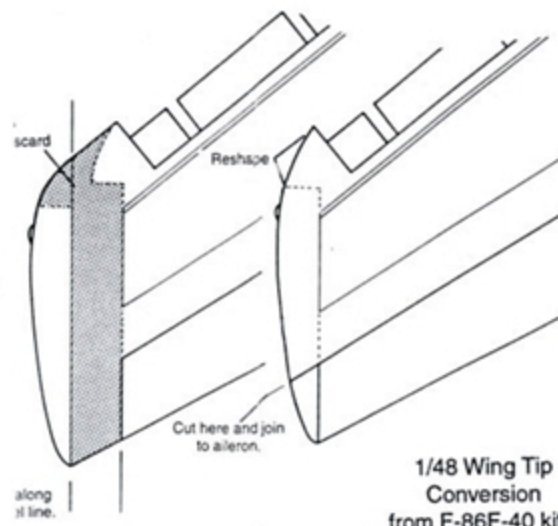

1/48 Wing Tip Conversion from F-86F-40 kits. (long wing Sabre)

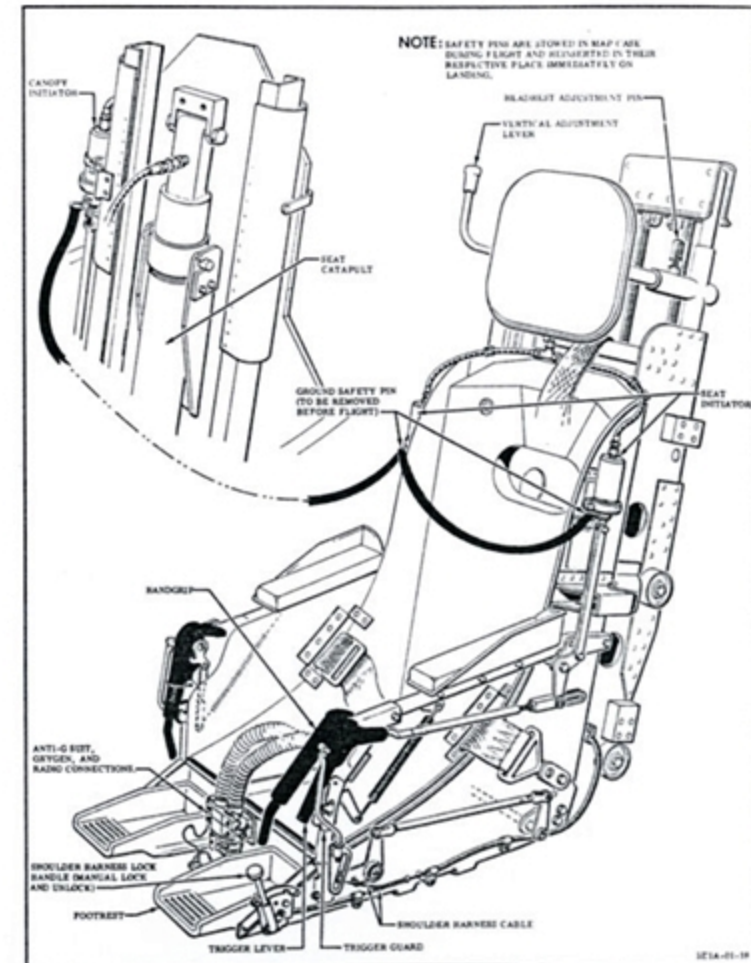

NOTE: SAFETY PINS ARE STORED IN MAP CASE DURING FLIGHT AND RECOVERED IN THEIR RESPECTIVE PLACES IMMEDIATELY ON LANDING.