

SOVIET TACTICAL RECCE AIRCRAFT 1:48 SCALE PLASTIC KIT



eduard

intro

ProfiPACK



The MiG-21 was one of a long list of Mikoyan-Gurevich products to be integrated into the armed forces of the Soviet Union, the Warsaw Pact, and allied client states. Its predecessors included such notable types as the MiG-15, MiG-17 and the supersonic MiG-19. The roots of this project reach back to the first half of the fifties. In 1954, the Ye-1 project came to an end, and was quickly picked up by the Ye-2. Both had a swept wing. The first machine to feature the delta wing was the Ye-4, which first took to the air on June 16th, 1955. It was also demonstrated a year later at the Moscow airfield Tushino. The first of the new line to enter production was the MiG-21F, which together with the MiG-21P and F-13 represented the first generation of the MiG-21, and was in production through the end of the fifties and the beginning of the sixties. Subsequent versions included the PF, FL, PFM, R, S, N and PD, the production of which peaked at the end of the sixties. The third generation started production in 1968, which included such versions as M, SM, MF, SMT, bis among others. Simultaneously, two-seat training versions were also produced designated MiG-21U, UM and US. Production of the MiG-21 ended in 1985, and was put into service with some fifty nations. Over the course of the cold war, the opponents of the MiG-21 included the likes of the Northrop F-5 Freedom Fighter and the Dassault Mirage III. NATO assigned it the reporting name 'Fishbed'. It became the most produced supersonic fighter in terms of quantity. The new machines came off Soviet production lines in Moscow, Gorky and Tbilisi. The MiG-21F-13 was also built under license in Czechoslovakia and the MiG-21FL, M and bis in India by Hindustan Aeronautics Ltd. The Soviet Union produced 10,645 examples of all versions, 194 were built in Czechoslovakia and 657 in India. Outside of the Soviet Union, the type flew with a long list of nations on all continents with the exception of Australia. The MiG-21 participated in combat in Vietnam, the Indo-Pakistan wars, the Cuban participation in Angola and in the Arab world's attempt to eliminate Israel. Thanks to the high volume of use, the highest number of aces produced on the type was in Vietnam. The top of the ladder is occupied by Nguyen Van Coc with nine kills. The type serving as a fighter-bomber served with the Soviet Union and other nations of the Warsaw Pact into the eighties, when it began to be displaced by the MiG-29 Fulcrum.

This kit is specific to the building of a model of the MiG-21R. In factory documentation, the export version is identified as 'Izdelye 94RA' and the version built for Soviet armed forces as 'Izdelye 94R'. It was powered by a Tumanskiy R-11F2-300. Hardpoints could still be loaded with RS-3US, R-3S missiles, UB-16-57 rocket pods, S-24 unguided rockets and bombs up to 500kg in size. NATO assigned MiG-21PFM the codename 'Fishbed H'.

úvodem

MiG-21 byl další konstrukcí kanceláře Mikojan-Gurjevič, která se zařadila do výzbroje Sovětského svazu, zemí Varšavské smlouvy a dalších ozbrojených sil. Jeho předchůdci byly tak významné typy jako MiG-15, MiG-17 či nadzvukový MiG-19. Kořeny vývoje letounu sahají do první poloviny 50. let minulého století. V roce 1954 byl dokončen projekt Je-1, velmi rychle nahrazený druhým prototypem Je-2. Oba měly šípové křídlo. Prvním strojem s delta křídlem byl prototyp Je-4, který se do vzduchu dostal poprvé 16. června 1955. Představil se také na letecké přehlídce, která se konala o rok později na moskevském letišti Tušino. Jako první se do sériové výroby dostala verze MiG-21F, která společně s MiG-21P a MiG-21F-13 reprezentovala první generaci tohoto typu, vyráběnou na přelomu 50. a 60. let minulého století. Následovaly další, pokročilejší verze – PF, FL, PFM, R, S, N a PD, jejichž produkce vyvrcholila ve druhé polovině 60. let. Od roku 1968 probíhala výroba třetí generace, která zahrnovala například verze M, SM, MF, SMT, bis a další. Souběžně se stavěly také dvoumístné cvičné jednadvacítky MiG-21U, UM a US. Výroba MiGů-21 skončila v roce 1985 a do výzbroje je zařadilo okolo 50 zemí světa. MiG-21 měl během studené války své protějšky v typech Northrop F-5 Freedom Fighter či Dassault Mirage III. Vojska NATO dalo typu kódové označení Fishbed. Stal se v největších počtech vyráběným nadzvukovým letounem. Nové stroje v Sovětském svazu sjížděly z továrních linek v Moskvě, Gorkém a Tbilisi. V licenci se stavěla verze MiG-21F-13 v Československu a MiG-21FL, M a bis v Indii u Hindustan Aeronautics Ltd. V Sovětském svazu vzniklo 10 645 exemplářů všech verzí, v Československu 194 kusů a v Indii 657 strojů. Kromě ozbrojených sil Sovětského svazu létal s řadě zemí, s výjimkou Austrálie na všech kontinentech. Zúčastnil se řady válečných konfliktů, včetně války ve Vietnamu, indicko-pákistánských potyček, kubánského tažení v Angole či arabské snahy o zničení Izraele. Díky největšímu zapojení do bojových akcí se největší počet stíhacích es zrodil ve Vietnamu. Na čele žebříčku stojí Nguyen Van Coc s devíti sestřely. V roli přepadového stíhacího letounu sloužily MiGy-21 v Sovětském svazu a dalších zemích Varšavské smlouvy až do 80. let, kdy jej jako plnohodnotná náhrada začaly z prvoliniové služby vytlačovat nové MiGy-29 Fulcrum.

Z této stavebnice si můžete postavit MiG-21R. V tovární dokumentaci tato verze figuruje pod označením Izdělje 94RA pro exportní stroje a Izdělje 94R pro letouny určené pro sovětské ozbrojené síly. Poháněl jej motor Tumanskiy R-11F2-300. Podvěsnou výzbroj tvořily rakety RS-3US, R-3S popř. raketové bloky UB-16-57, protizemní neřízené rakety S-24 a pumy do 500 kg. V kódu NATO nesly stroje označení Fishbed H.

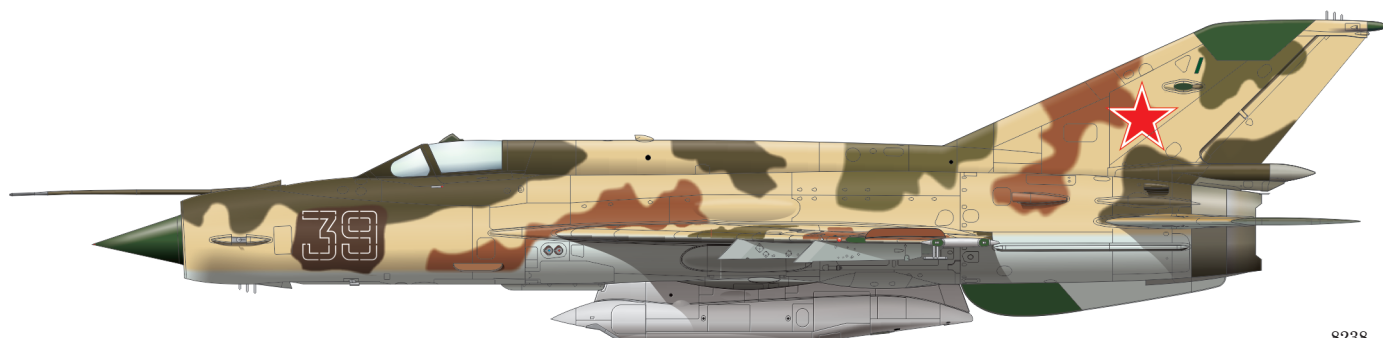

ATTENTION



UPOZORNĚNÍ



ACHTUNG



ATTENTION



注意



Carefully read instruction sheet before assembling. When you use glue or paint, do not use near open flame and use in well ventilated room. Keep out of reach of small children. Children must not be allowed to suck any part, or pull vinyl bag over the head.



Před započítím stavby si pečlivě prostudujte stavební návod. Při používání barev a lepidel pracujte v dobře větrané místnosti. Lepidla ani barvy nepoužívejte v blízkosti otevřeného ohně. Model není určen malým dětem, mohlo by dojít k požití drobných dílů.

INSTRUCTION SIGNS * INSTR. SYMBOLS * INSTRUKTION SINNBILDEN * SYMBOLES * 記号の説明

OPTIONAL
VOLBABEND
OHNOUTOPEN HOLE
VYVRTAT OTVORSYMMETRICAL ASSEMBLY
SYMETRICKÁ MONTÁŽREMOVE
ODŘÍZNOUTREVERSE SIDE
OTOČITAPPLY EDUARD MASK
AND PAINT
POUŽÍT EDUARD MASK
NABARVIT

PARTS



DÍLY



TEILE



PIĘCES



部品

PLASTIC PARTS

A>

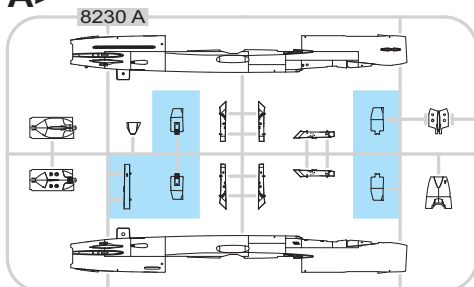

C>

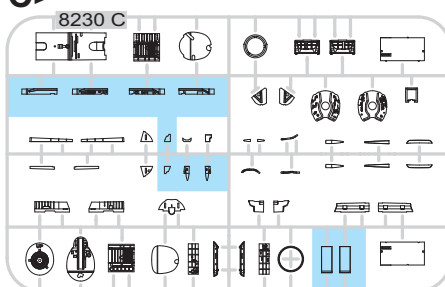

D>

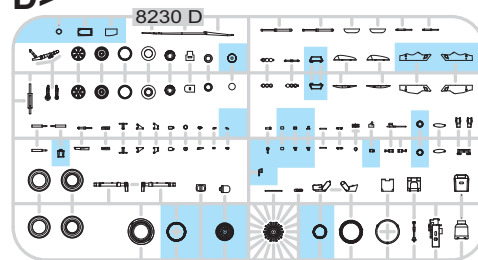

E> 2 pcs.

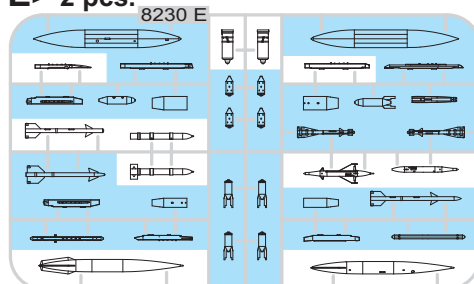

F>

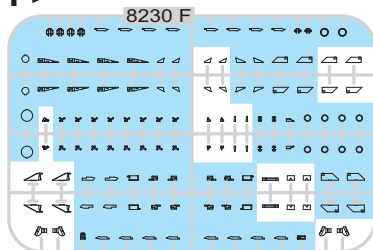

G>

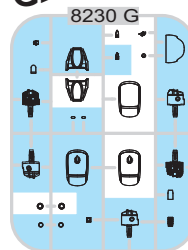

H>

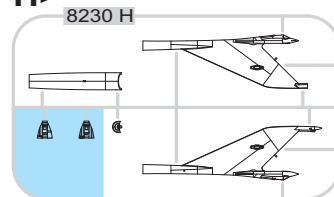

P>

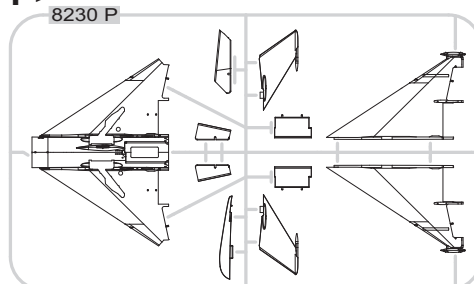

R>

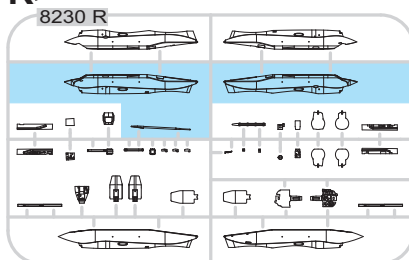
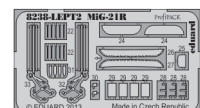
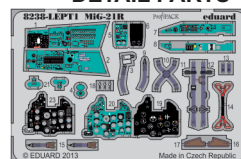
PE - PHOTO ETCHED
DETAIL PARTS

-Parts not for use. -Teile werden nicht verwendet. -Pièces à ne pas utiliser.
-Tyto díly nepoužívejte při stavbě. - 使用しない部品

COLOURS



BARVY



FARBEN



PEINTURE



色

GSI Creos (GUNZE)		
AQUEOUS	Mr.COLOR	
H 1	C1	WHITE
H 3	C3	RED
H 4	C4	YELLOW
H 5	C5	BLUE
H 12	C33	FLAT BLACK
H 26	C66	BRIGHT GREEN
H 27	C44	SAND
H 37	C43	WOOD BROWN
H 47	C41	RED BROWN
H 51	C11	LIGHT GRAY
H 53	C13	NEUTRAL GRAY
H 58	C27	INTERIOR GREEN

AQUEOUS	Mr.COLOR	
H 60	C16	GREEN
H 65	C18	BLACK GREEN
H 67	C115	LIGHT BLUE
H 70	C60	GRAY
H 77	C137	TIRE BLACK
H 84	C42	MAHOGANY
H 90	C47	CLEAR RED
H 94	C138	CLEAR GREEN
H 902	C302	GREEN
H 303	C303	GREEN
H 314	C314	BLUE
H 323	C323	LIGHT BLUE
H 324	C324	LIGHT GRAY

AQUEOUS	Mr.COLOR	
H 330	C330	DARK GREEN
H 332	C332	LIGHT GRAY
H 442	C122	LIGHT GREEN
H 442	C8	SILVER
H 442	C34	SKY BLUE
H 442	C80	COBALT BLUE

Mr.METAL COLOR		
MC213		STAINLESS STEEL
MC214		DARK IRON
MC218		ALUMINIUM
Mr.COLOR SUPER METALLIC		
SM06		CHROME SILVER

INTERIOR COLOUR BARVA INTERIÉRU

INTERIOR

60% C34 SKY BLUE + 20% C66 BRIGHT GREEN + 20% C80 COBALT BLUE

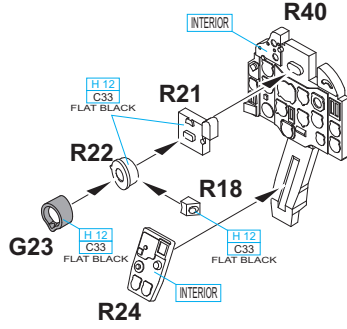
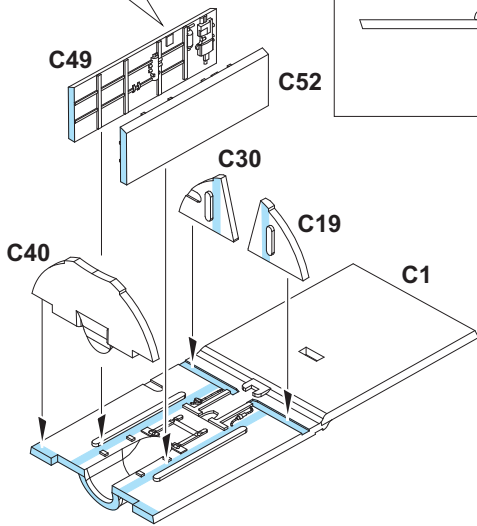
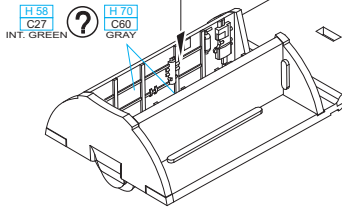
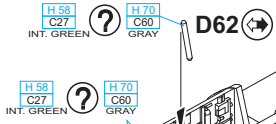
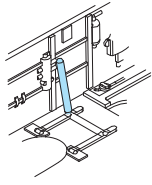

PE23 - MARKING E ONLY

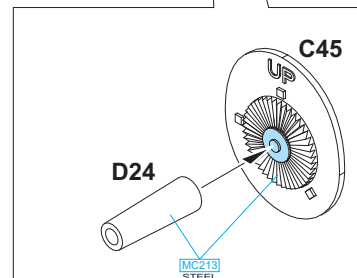
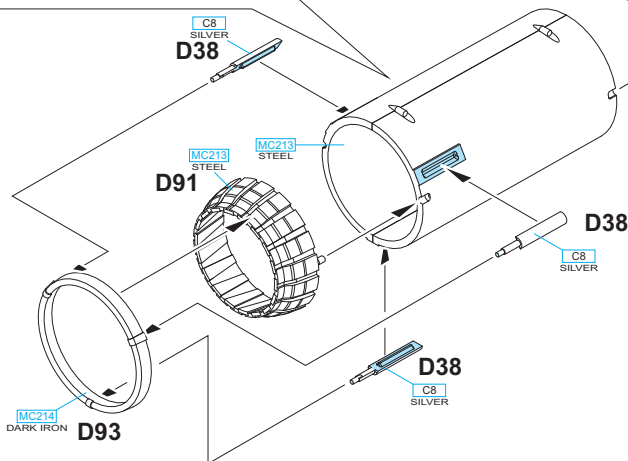
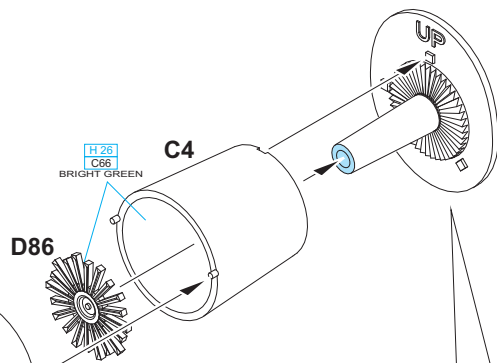
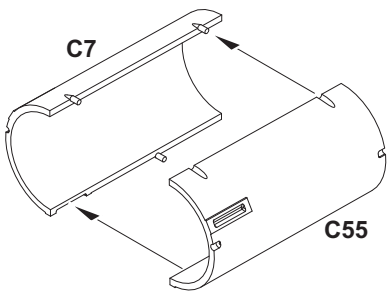
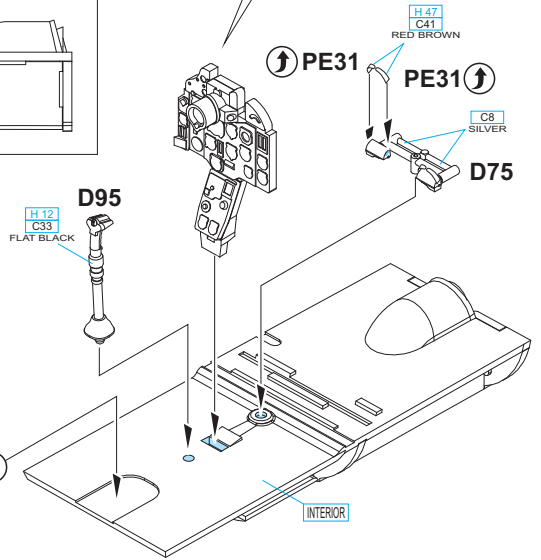
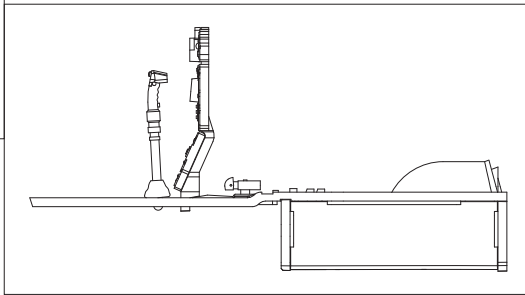
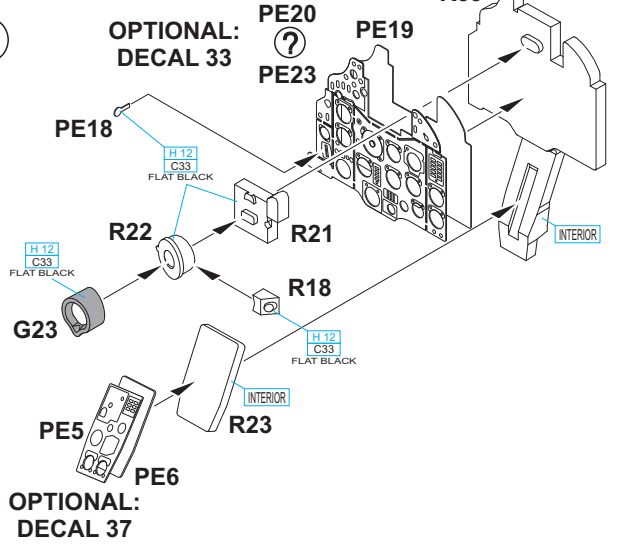

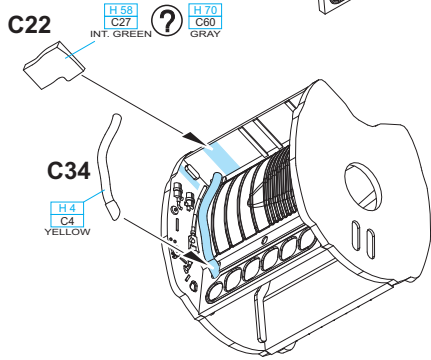
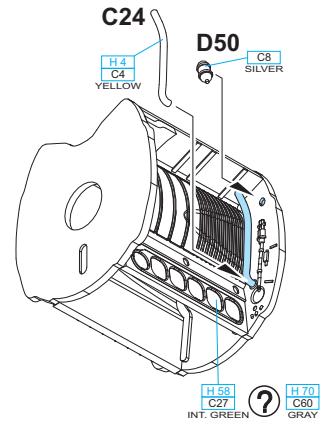
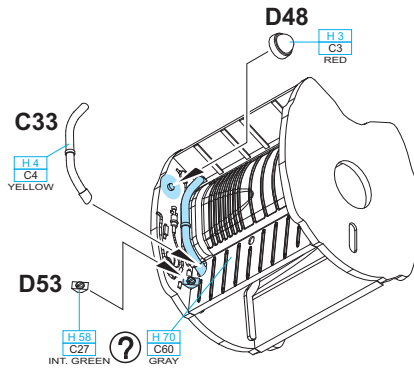
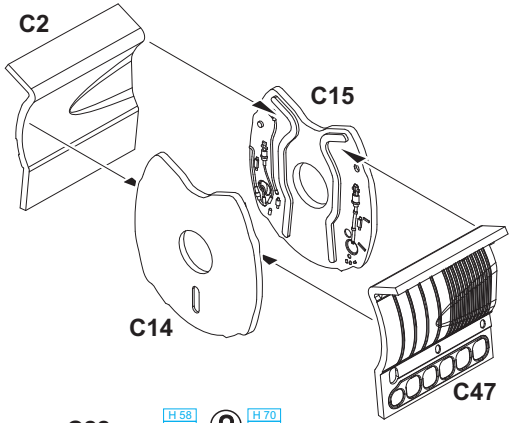

OPTIONAL:
DECAL 34

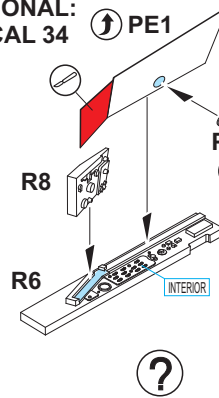

OPTIONAL:
DECAL 34, 35

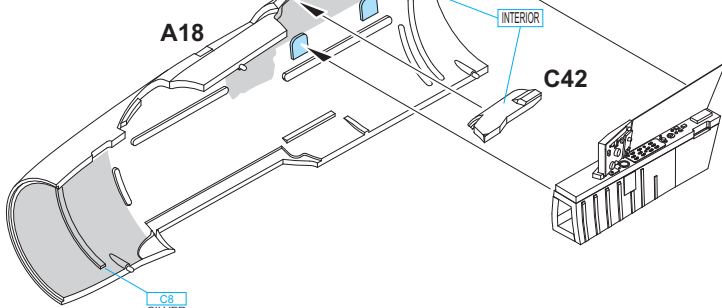
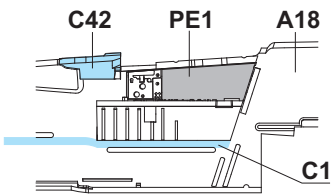
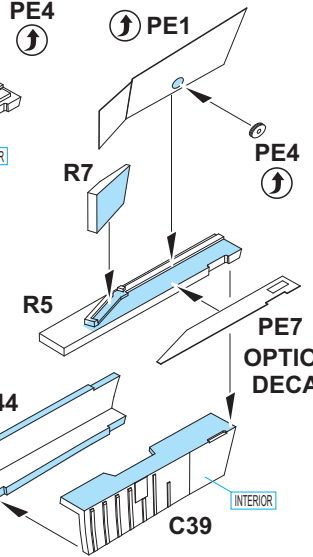

OPTIONAL:
DECAL 32

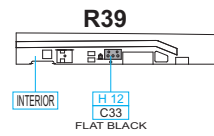

OPTIONAL:
DECAL 36

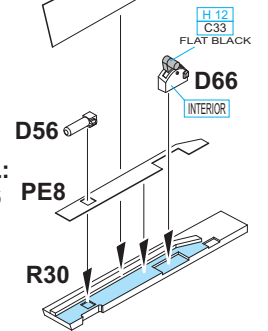

OPTIONAL:
DECAL 32

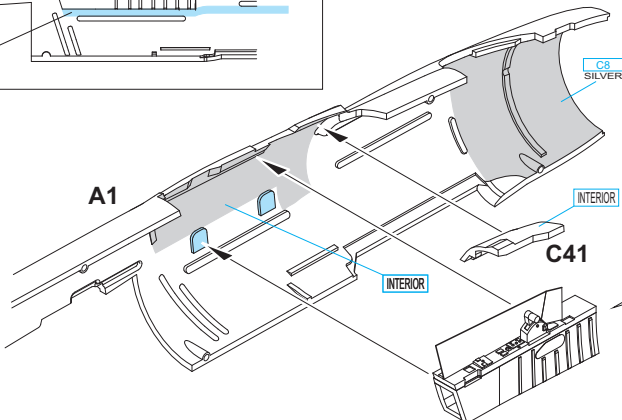
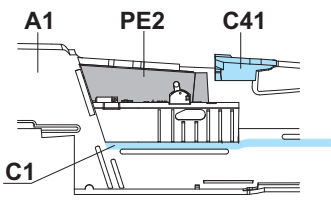
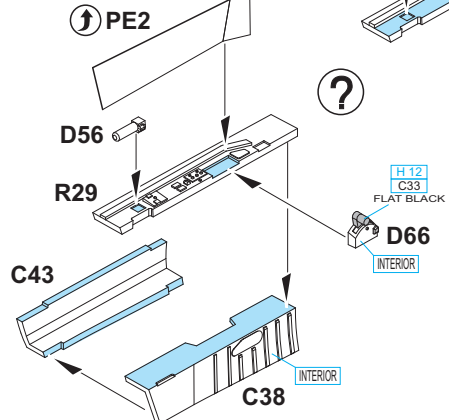

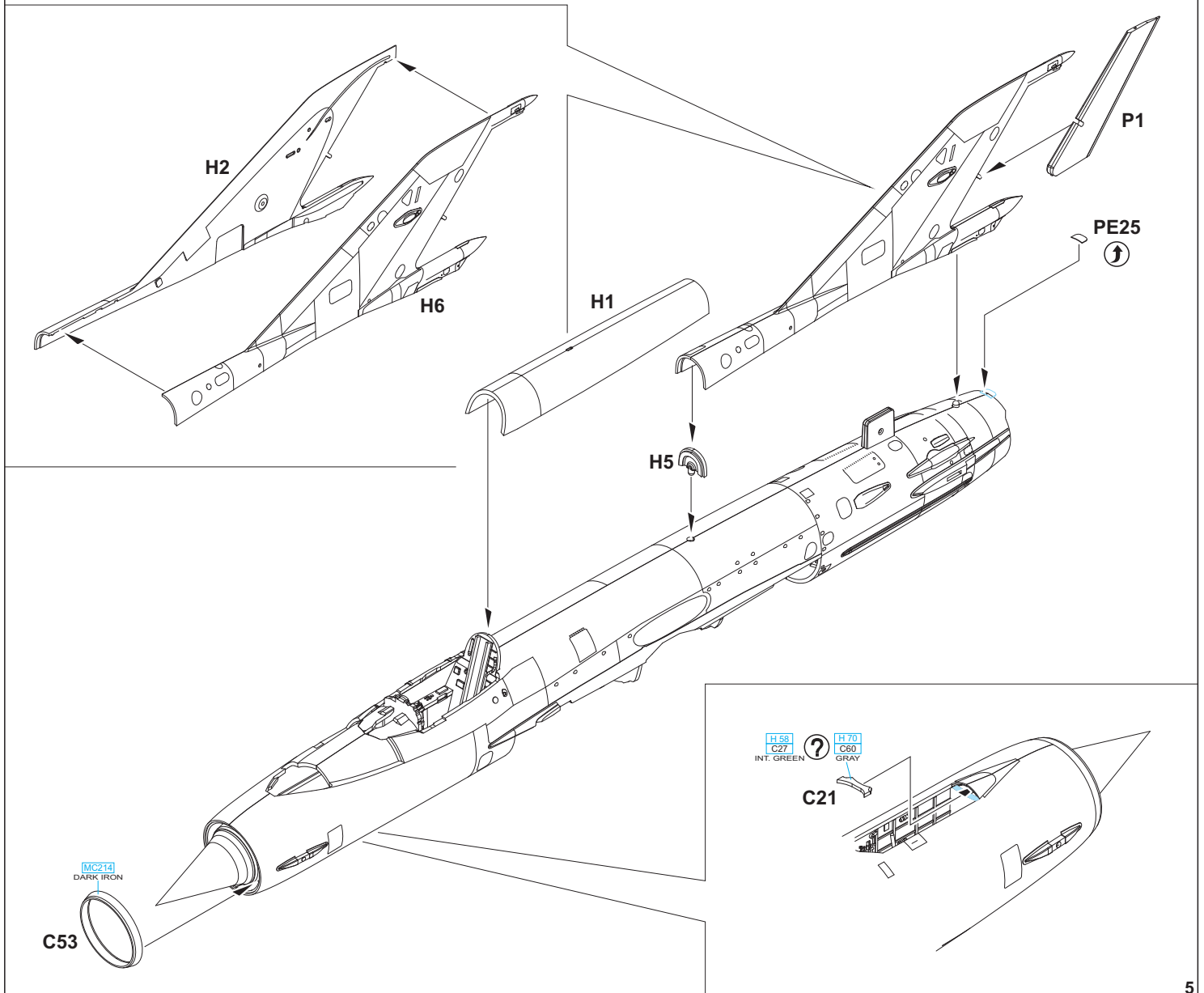
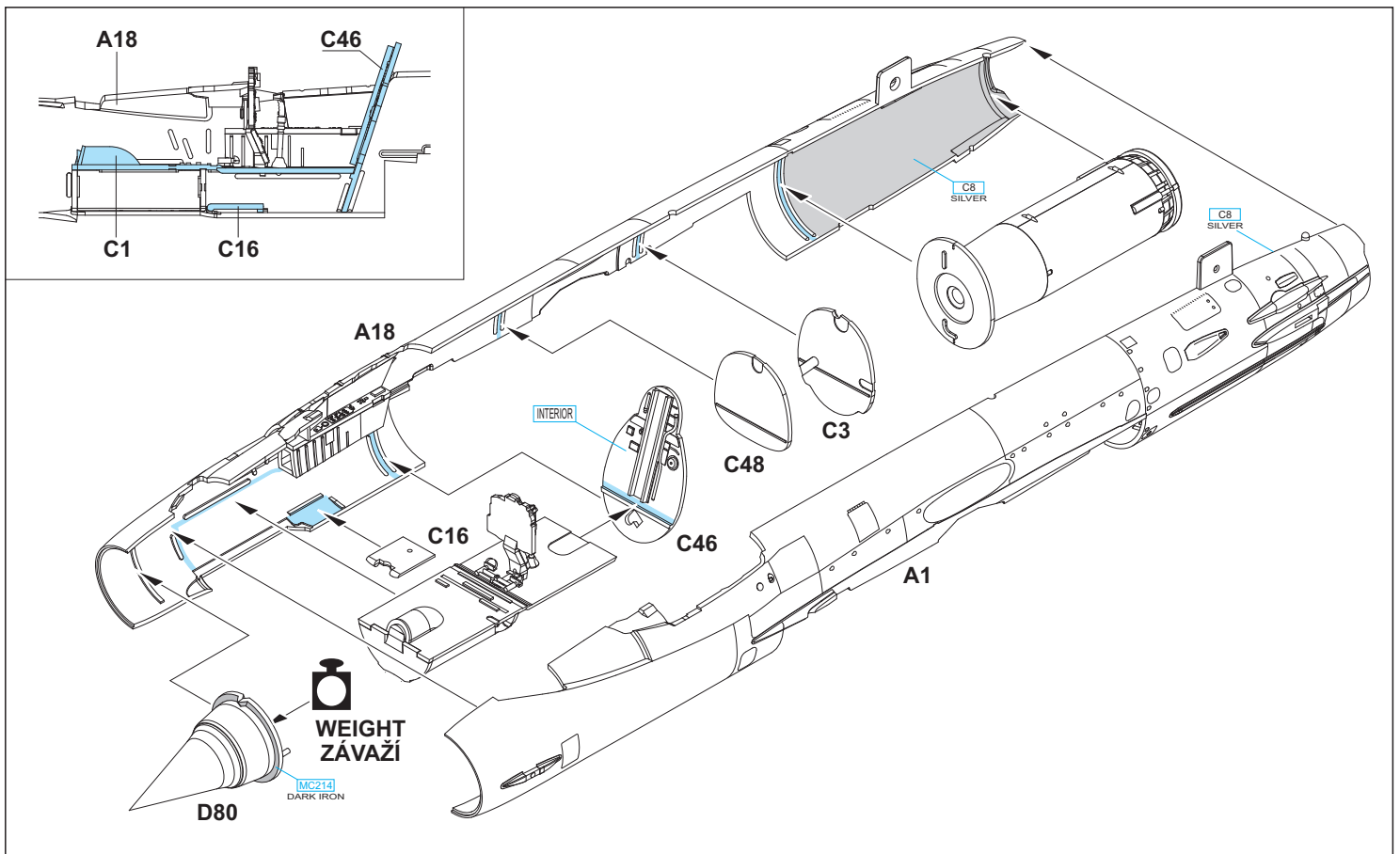

**FOR OPEN AIR BRAKES ONLY
JEN PRO OTEVŘENÉ ŠTÍTY**

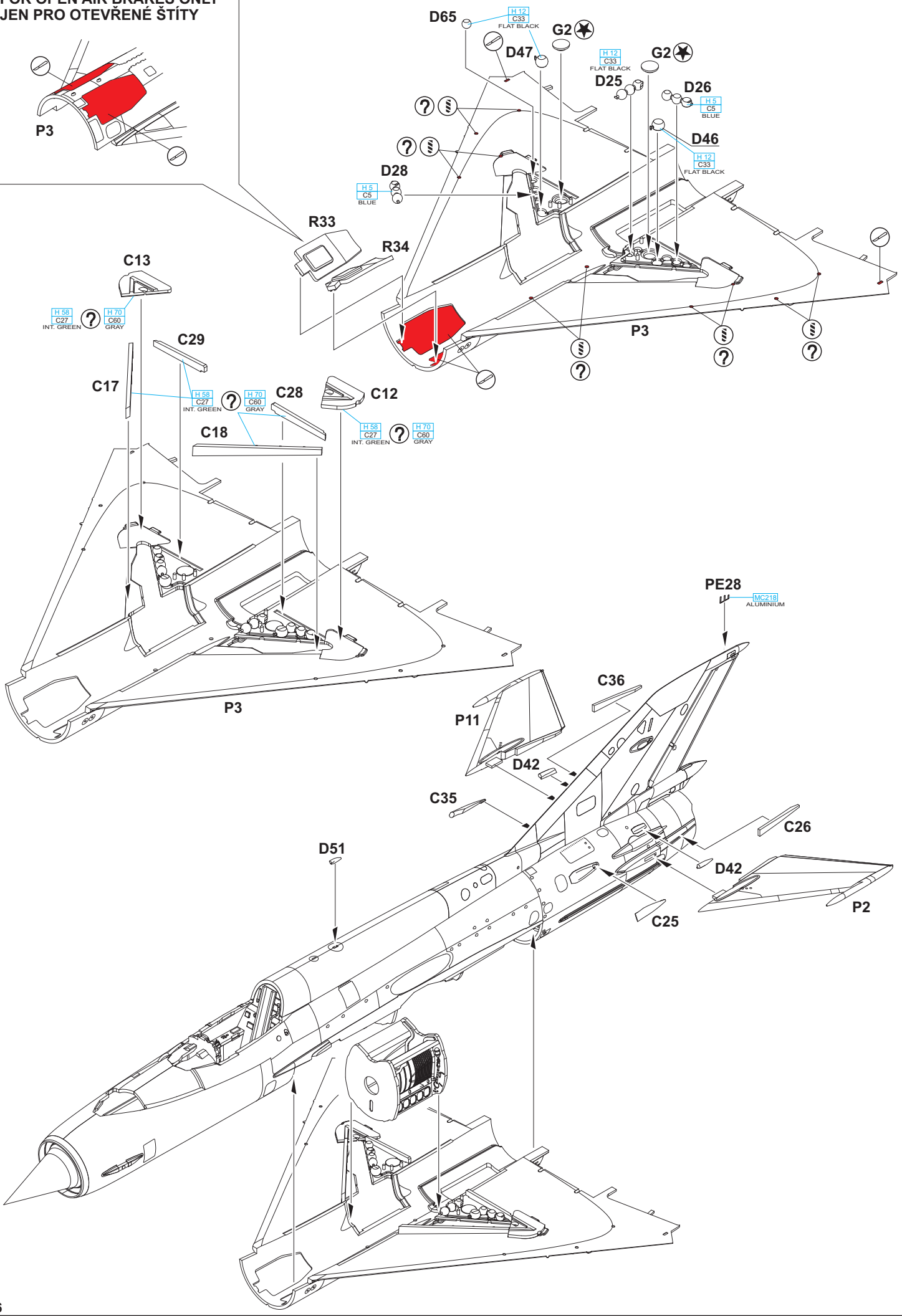
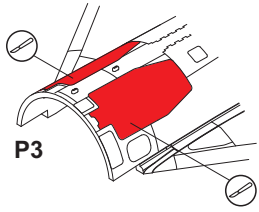

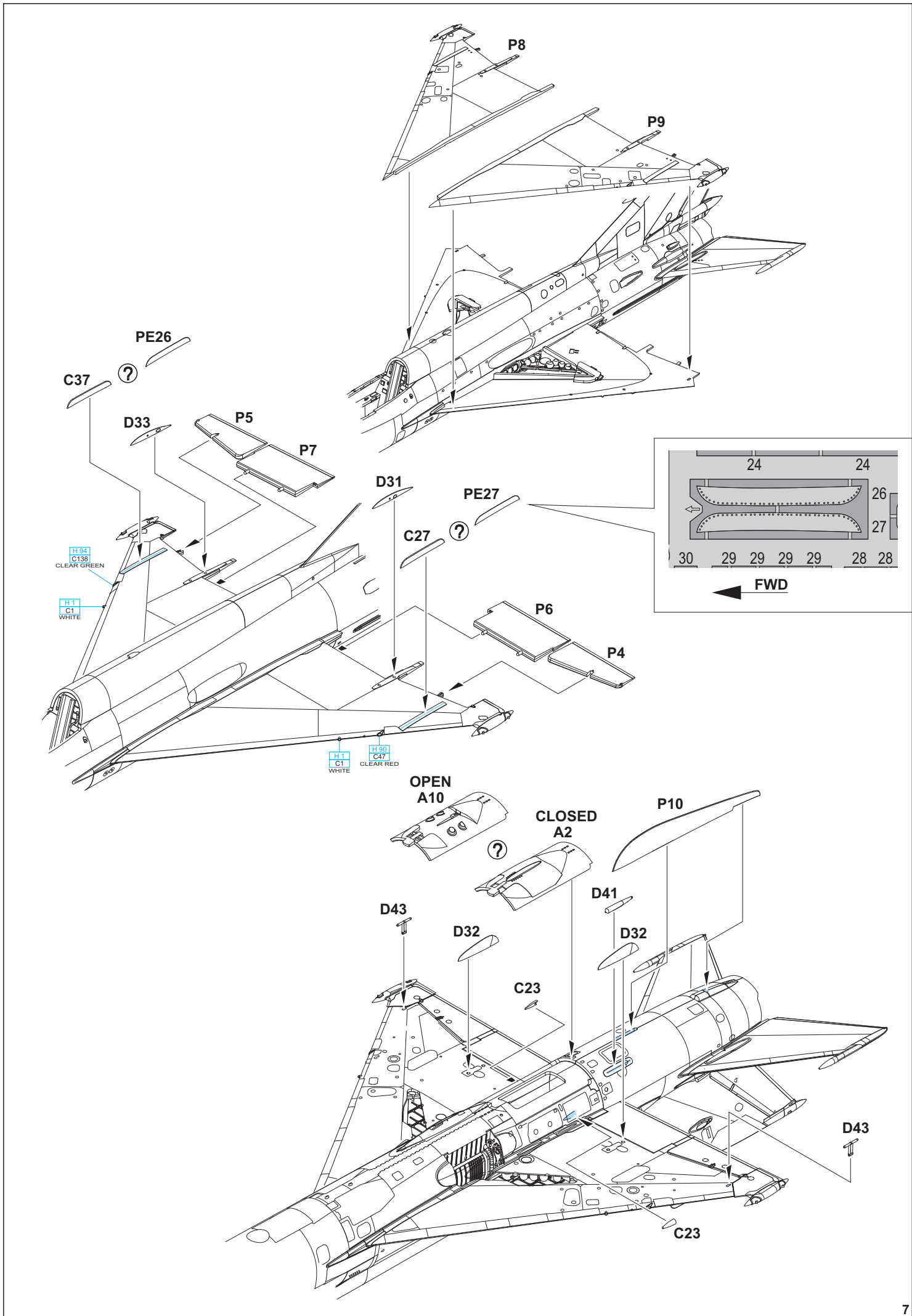

R36, R37, A9 - H4/C4 YELLOW
 MARKING **C** ONLY

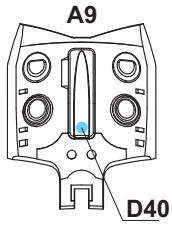

OPEN
 ?

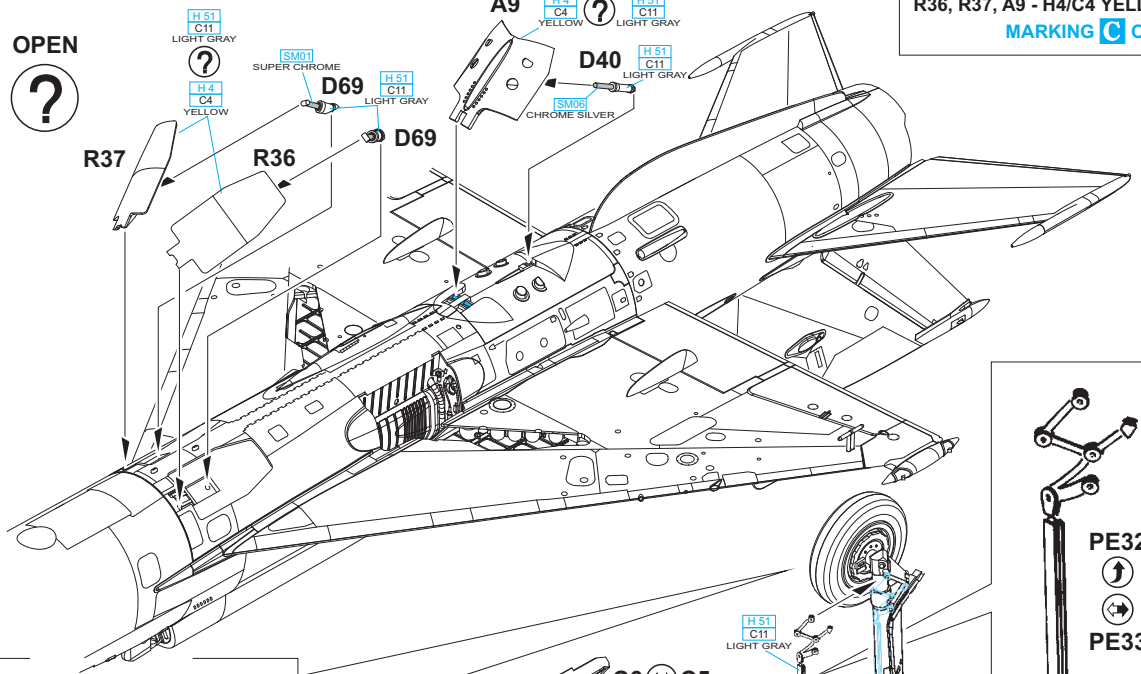

28°

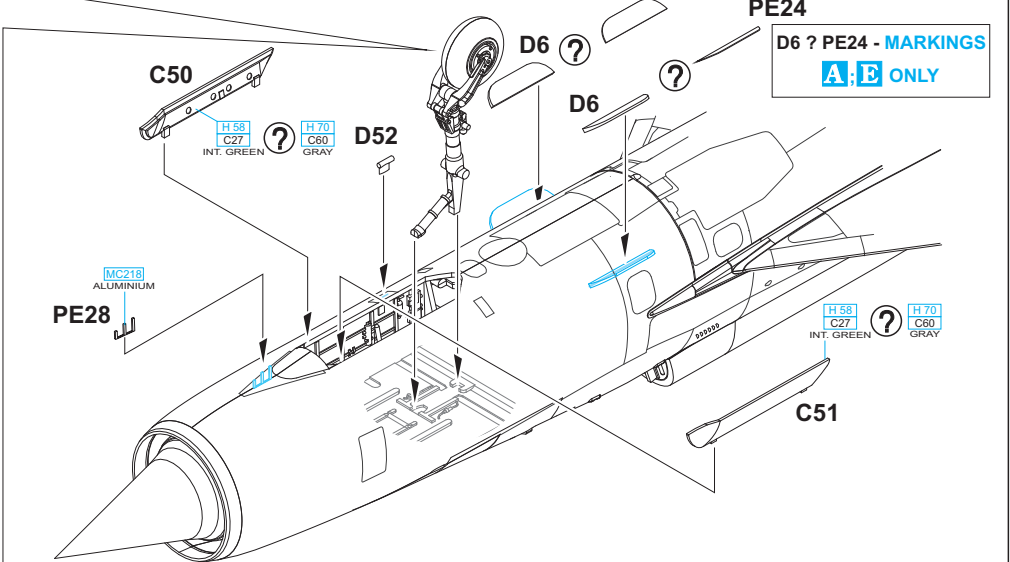
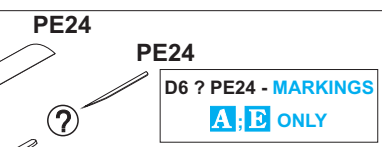
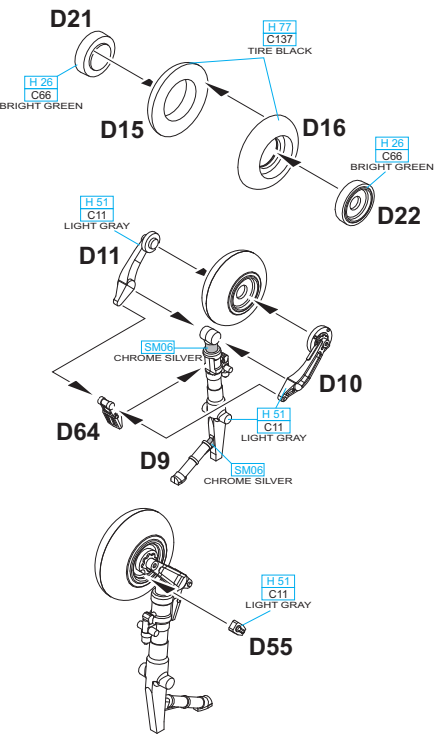
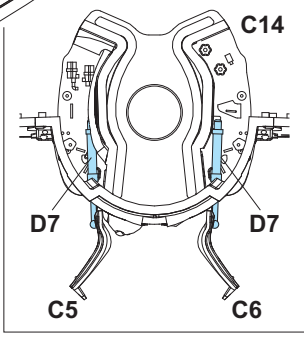
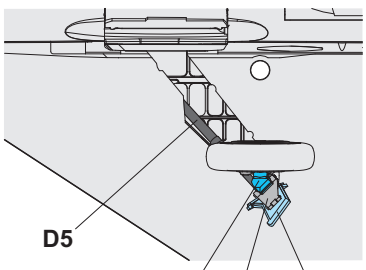
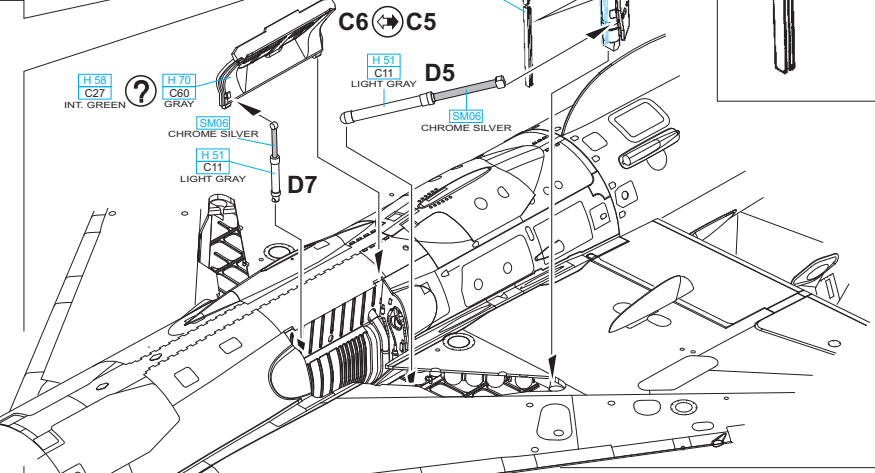
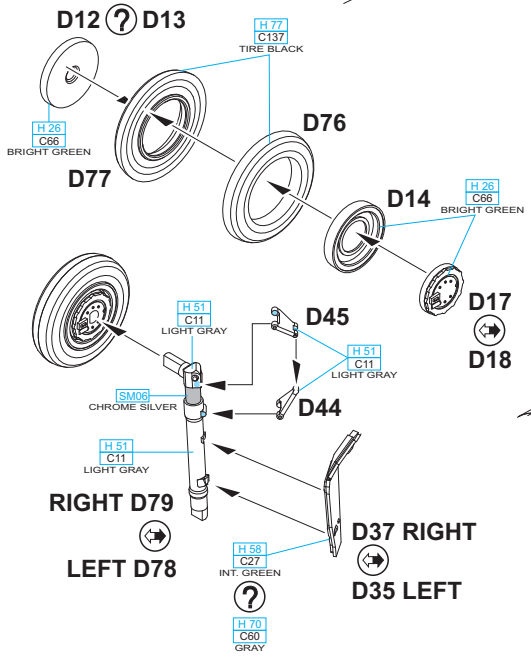
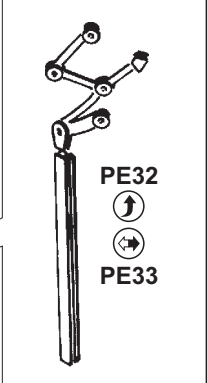

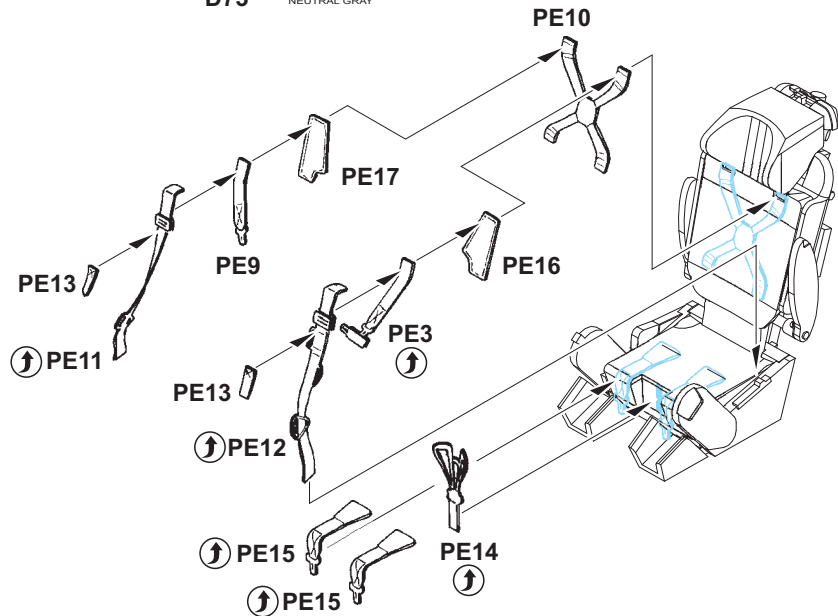
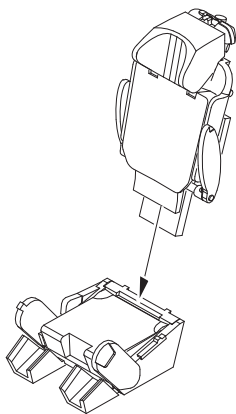
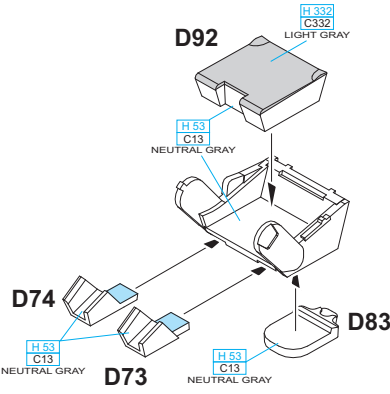
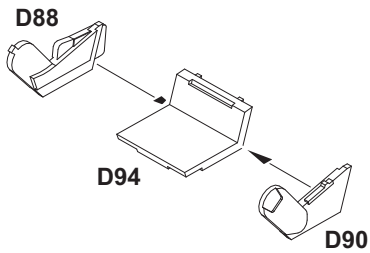
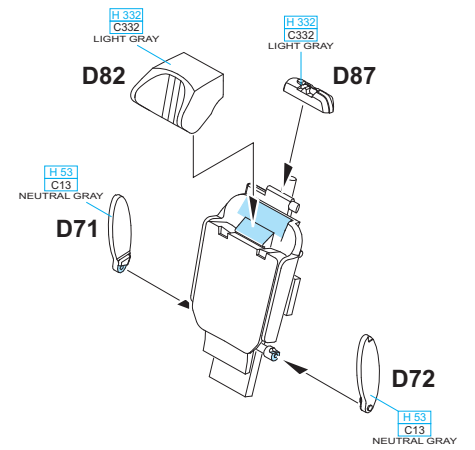
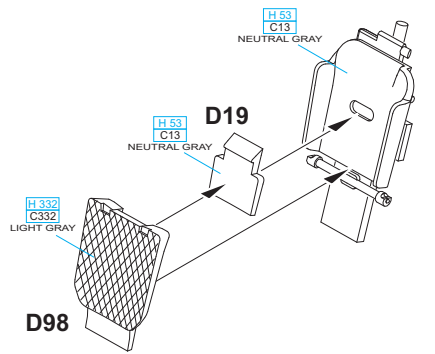
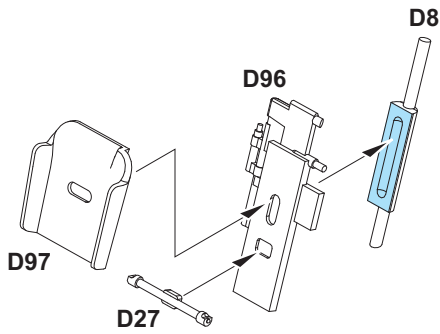
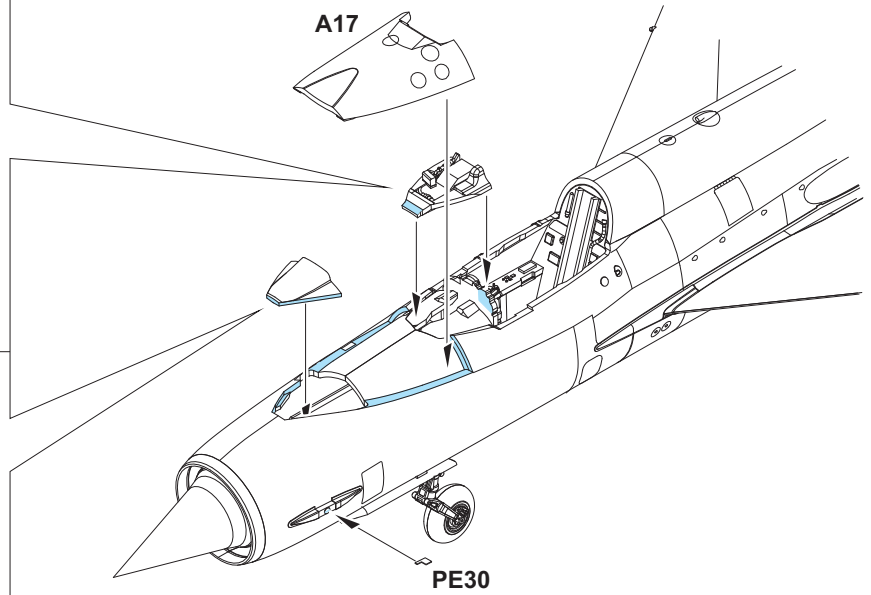
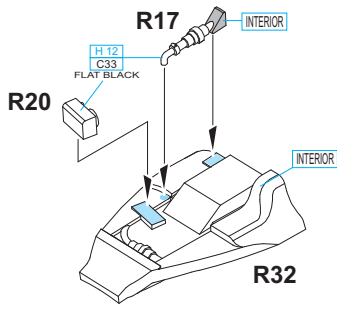

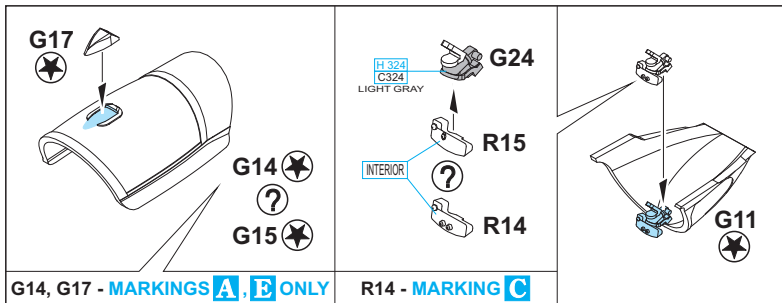

G14, G17 - MARKINGS **A, E** ONLY

R14 - MARKING **C**

MARKING **D** - BOTH MIRRORS
MARKINGS **B, C** - LEFT MIRROR ONLY

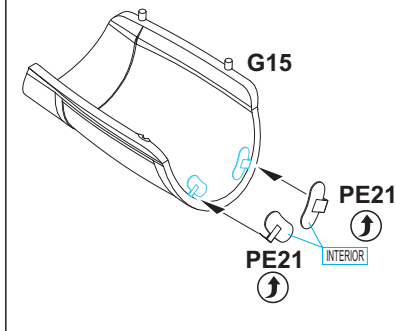

CLOSED CANOPY ONLY
JEN ZAVŘENÁ KABINA

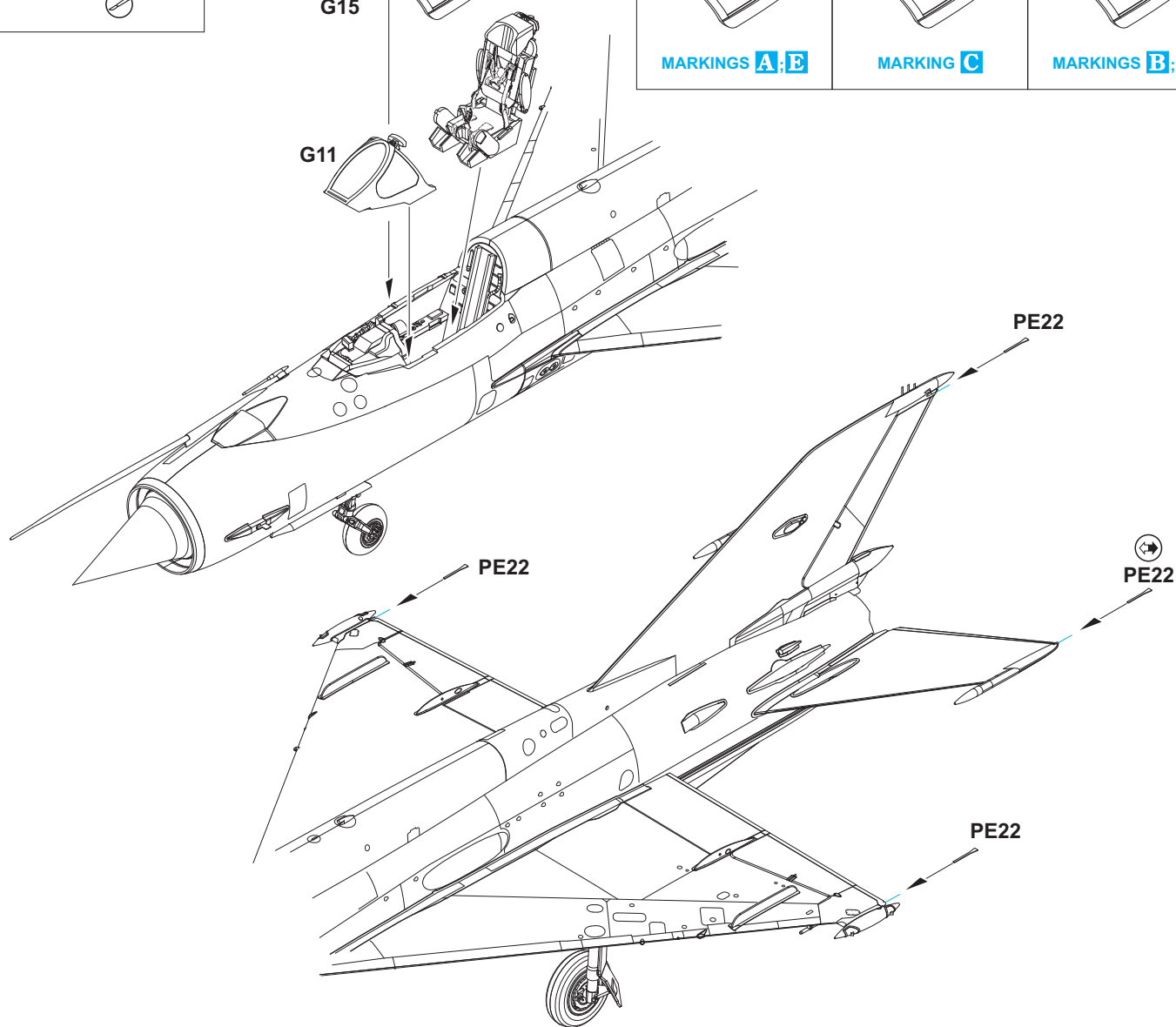
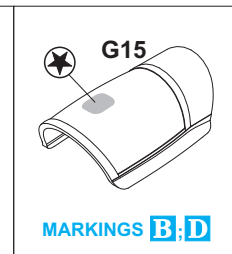
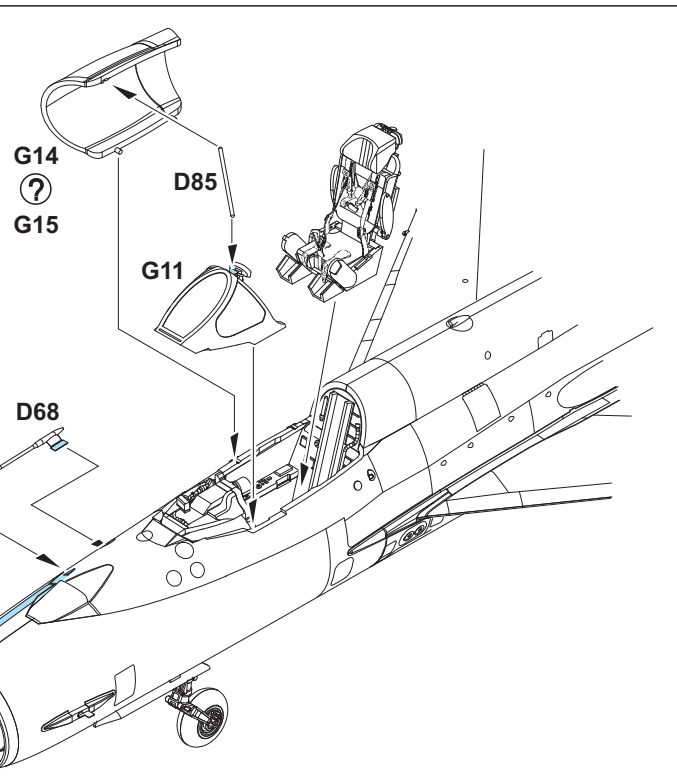
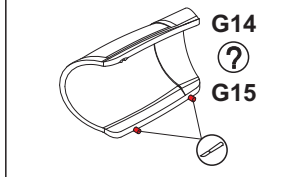

**EXTERNAL FUEL TANK 490I
PŘÍDAVNÁ NÁDRŽ 490I**
2 pcs.

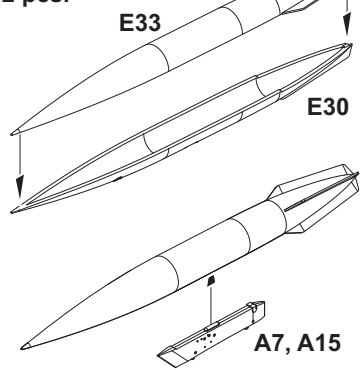

S-24
2 pcs.

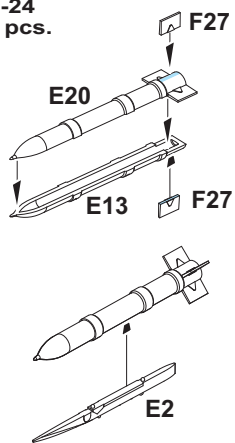

R-3S
2 pcs.

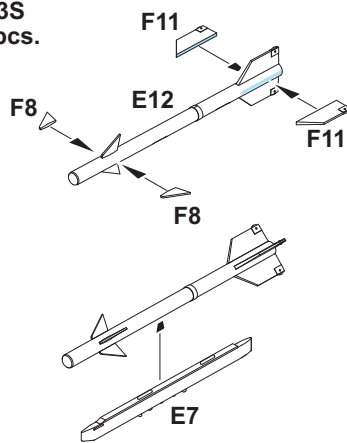

RS-2US
2 pcs.

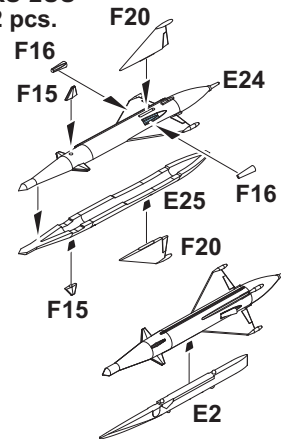

MARKINGS A, B, D, E

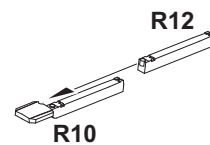
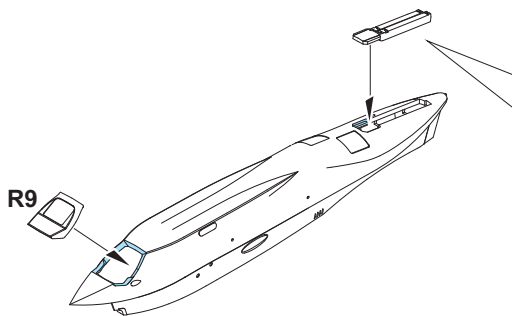
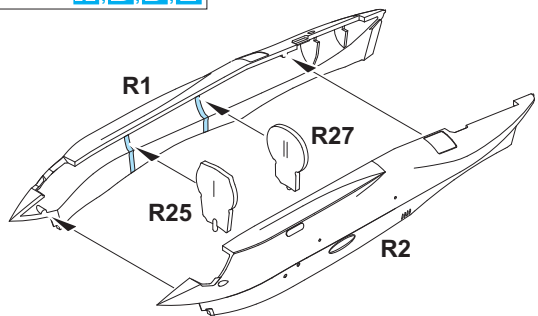

MARKING C

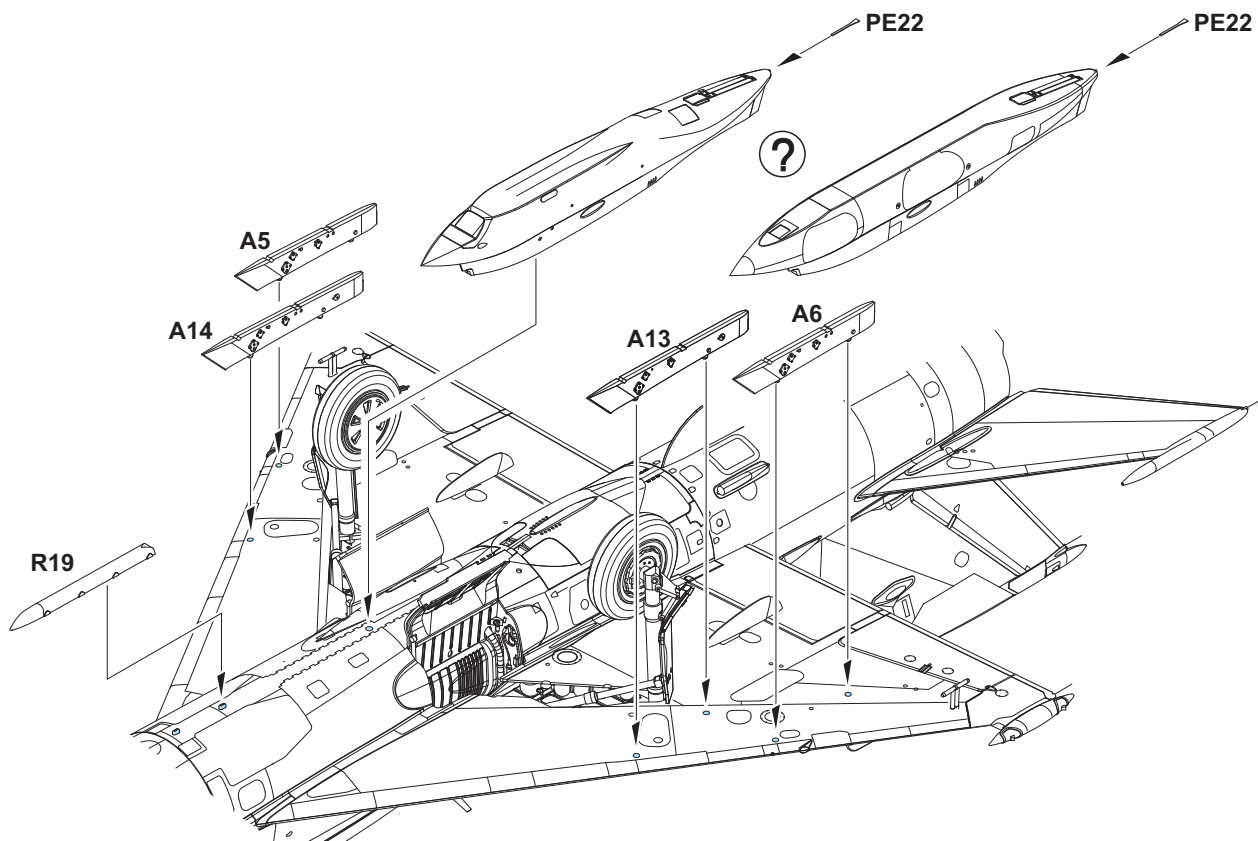
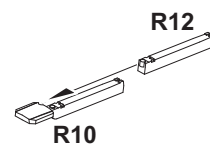
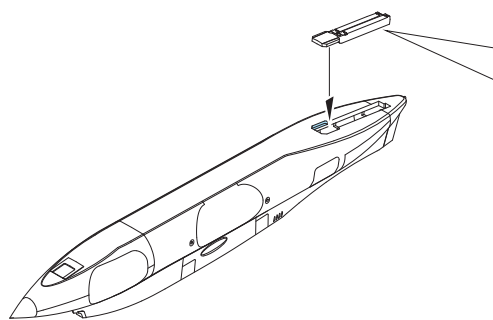
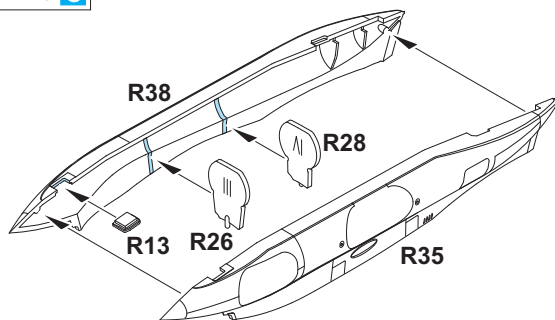

TO CHOOSE WEAPON AND EXTERNAL FUEL TANK OPTION PLEASE FOLLOW YOUR REFERENCE.

PRO VOLBU VÝZBROJE A PŘÍDAVNÝCH NÁDRŽÍ SE DRŽTE DOKUMENTACE KONKRÉTNÍHO STROJE.

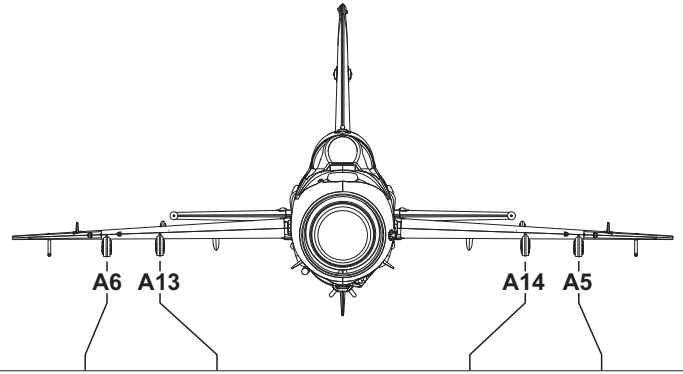

EXTERNAL FUEL TANK 490I

	A15	A7
S-24	E2	E2
RS-2US	E2	E2
R-3S	E7	E7

SPRD

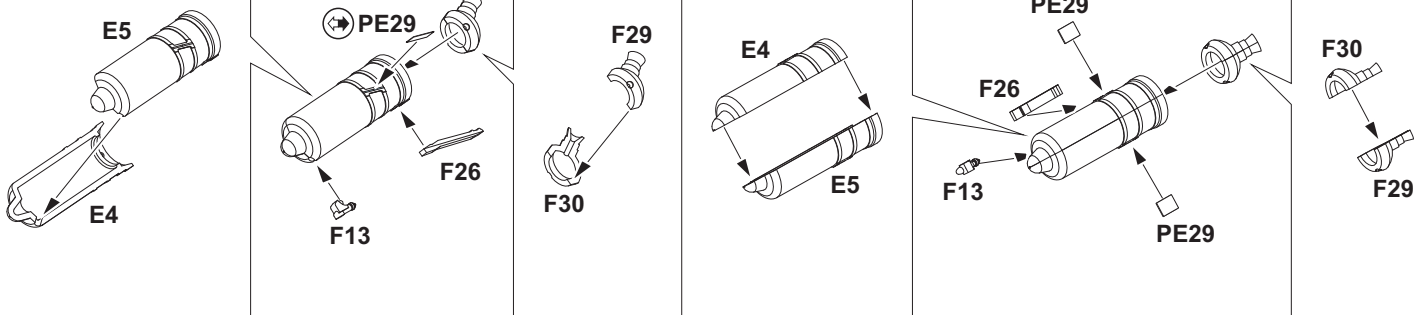

MARKING **A** ONLY ?

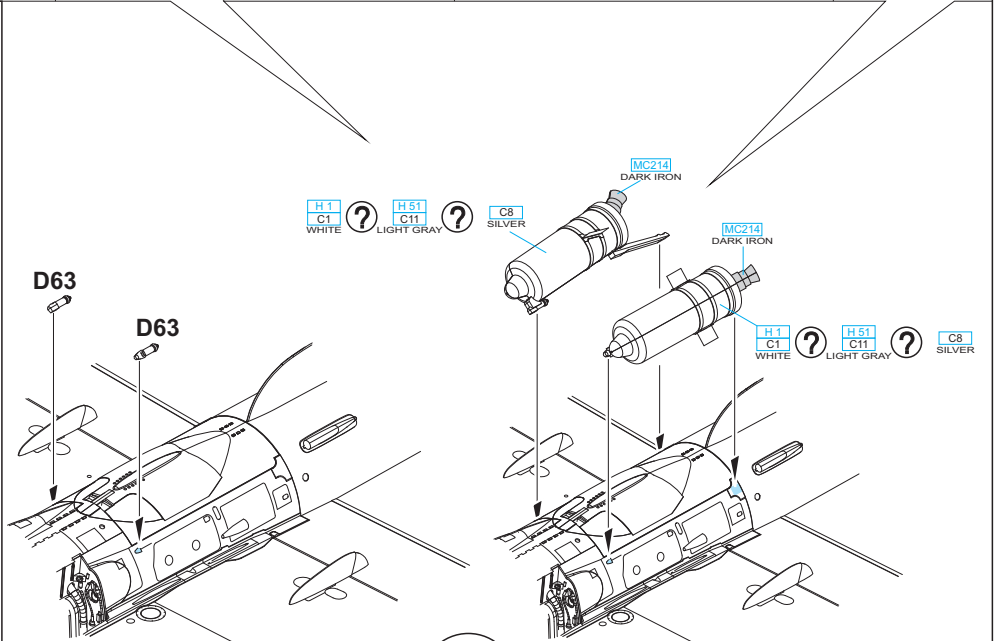
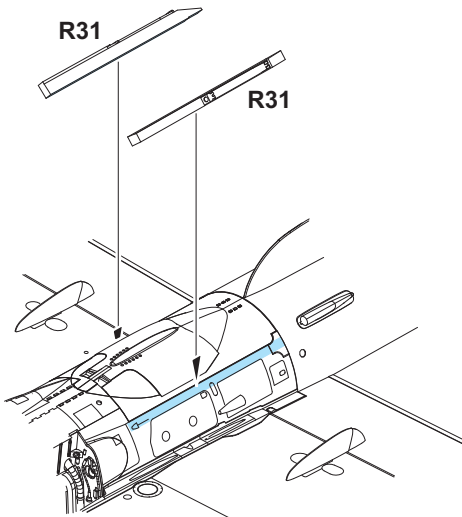

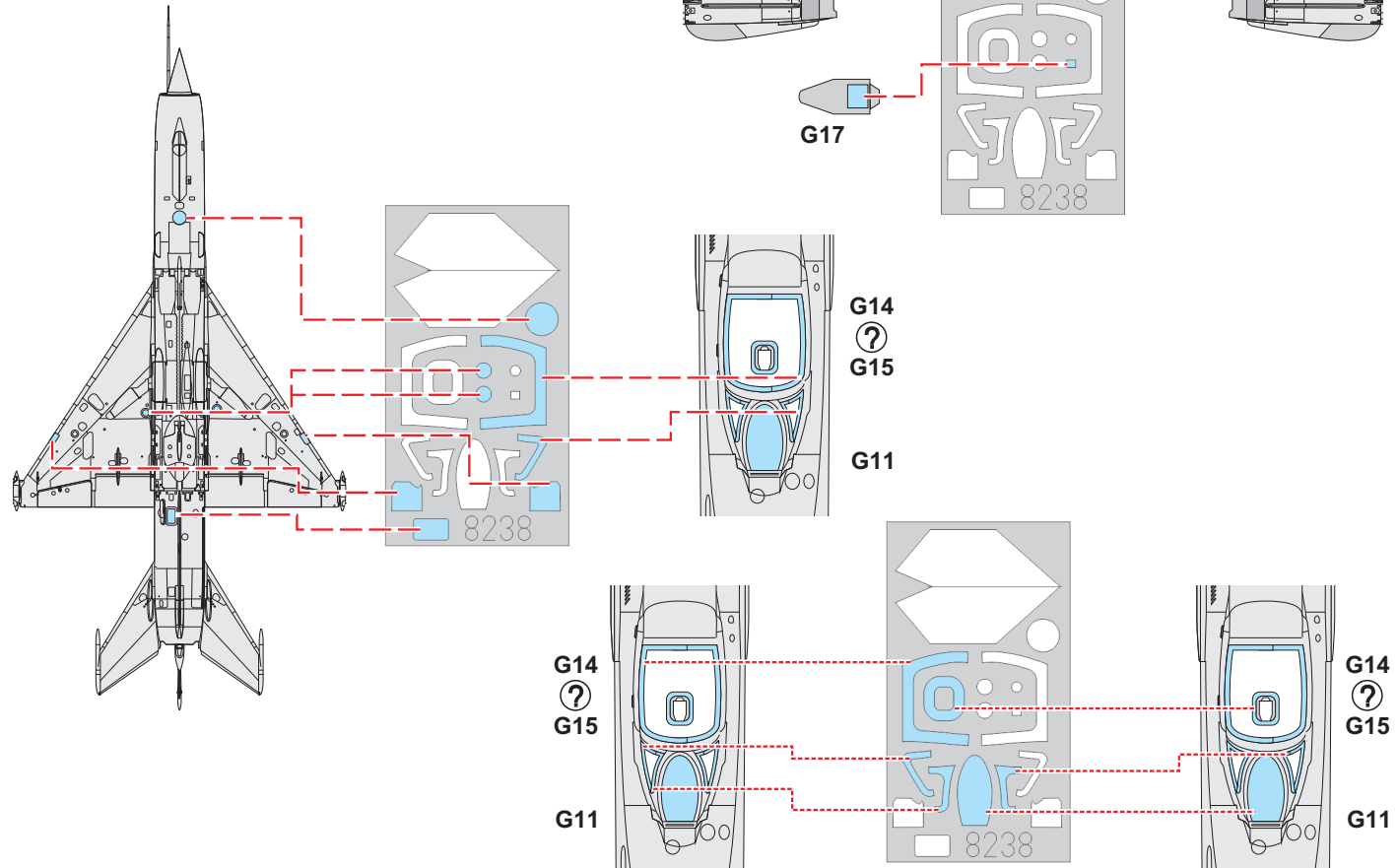

MiG-21R

STENCIL VARIANTS

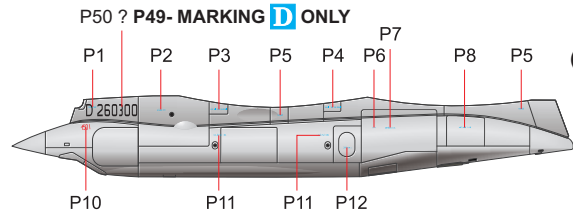

Type D pod; D kontejner
(Czech stencils; popisky v češtině)

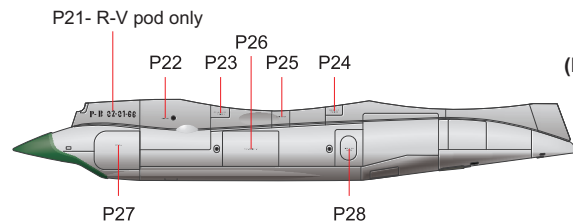
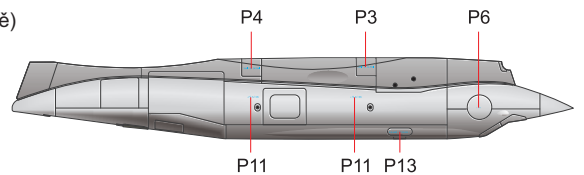

Type R-V pod / Type D pod
R-V kontejner / D kontejner
(Russian stencils; popisky v ruštině)

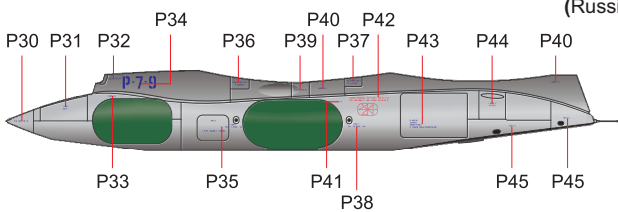
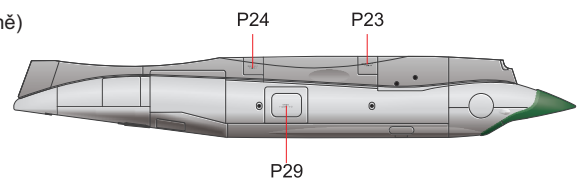

Type R pod; R kontejner
(Russian stencils; popisky v ruštině)

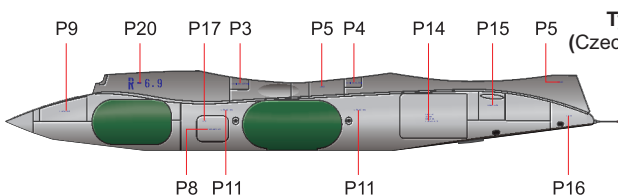
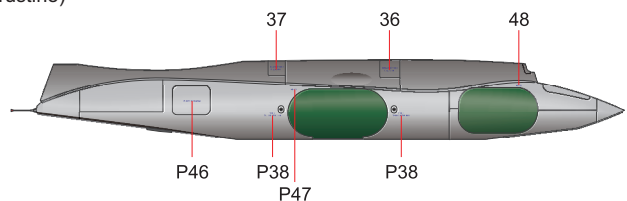

Type R pod; R kontejner
(Czech stencils; popisky v češtině)

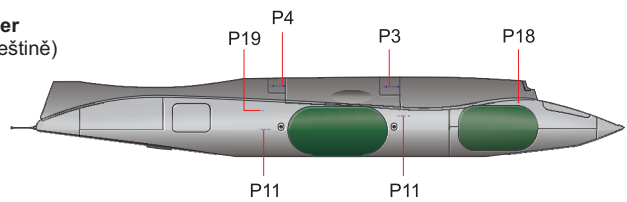

LEVÝ VNITŘNÍ PYLON
LEFT INSIDE PYLON

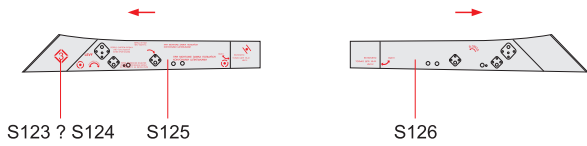

PRAVÝ VNITŘNÍ PYLON
RIGHT INSIDE PYLON



LEVÝ VNĚJŠÍ PYLON
RIGHT OUTSIDE PYLON



PRAVÝ VNĚJŠÍ PYLON
RIGHT OUTSIDE PYLON

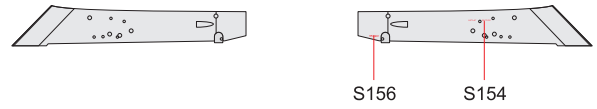

APU-7

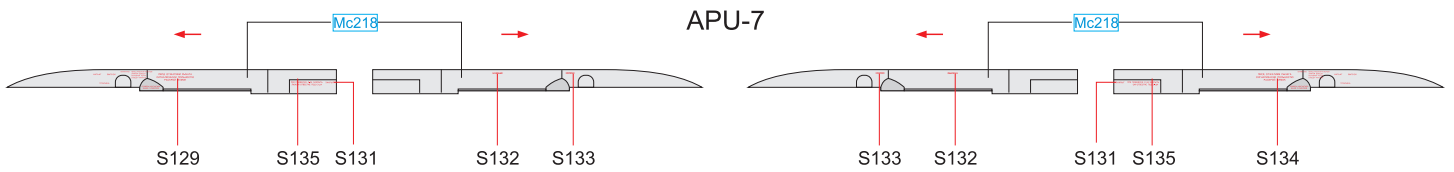

APU-13

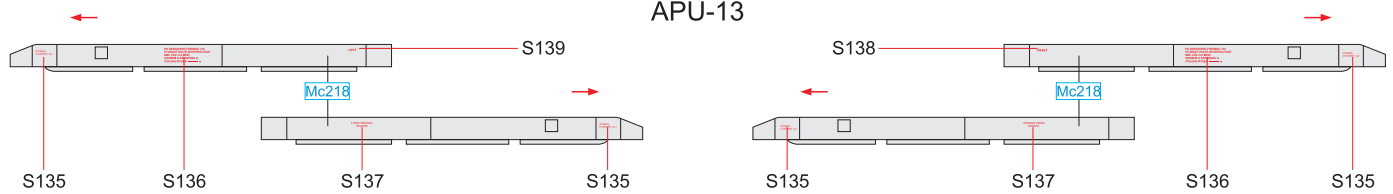

RS-2US

TOP

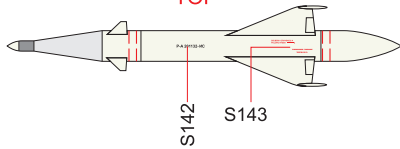

S-24

TOP

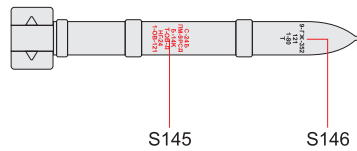

PODTRUPOVÝ PYLON
FUSELAGE PYLON

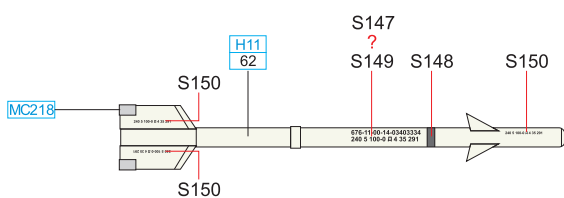
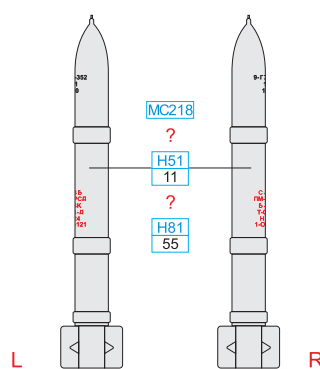
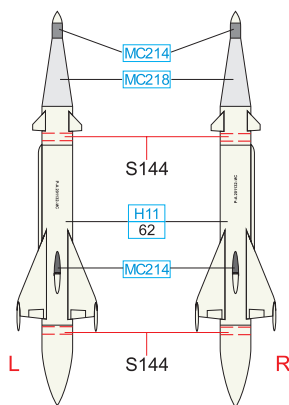
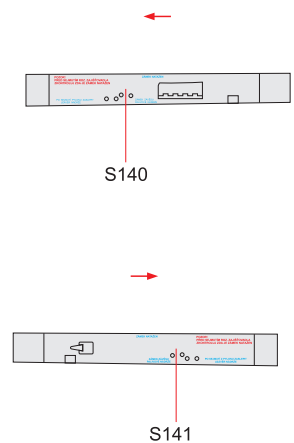

R-3S

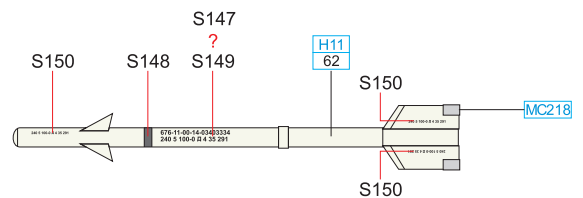

A Soviet Air Force, 263rd Independent Reconnaissance Air Squadron, Kabul Air Field, Afghanistan, 1981

Following the Soviet invasion of Afghanistan, recon aircraft appeared at local airfields. The 263rd Independent Reconnaissance Air Squadron (ORAE) moved to Afghanistan in early January 1980 and found its home at Bagram and Kandahar air bases. The squadron began to fly their aircraft from Kabul in late April, 1980, and stayed there till 1984. The MiG-21R depicted was one of the recon aircraft that operated from this air base. The camouflage scheme was created to match the appearance of the local landscape. Many Soviet aircraft flown in Afghanistan were equipped with chaff and flare dispensers. These could be carried by this specific aircraft as well, however this are not visible in photographs.

ČESKOU VERZI TEXTU NALEZNETE NA
www.eduard.com/s/8238

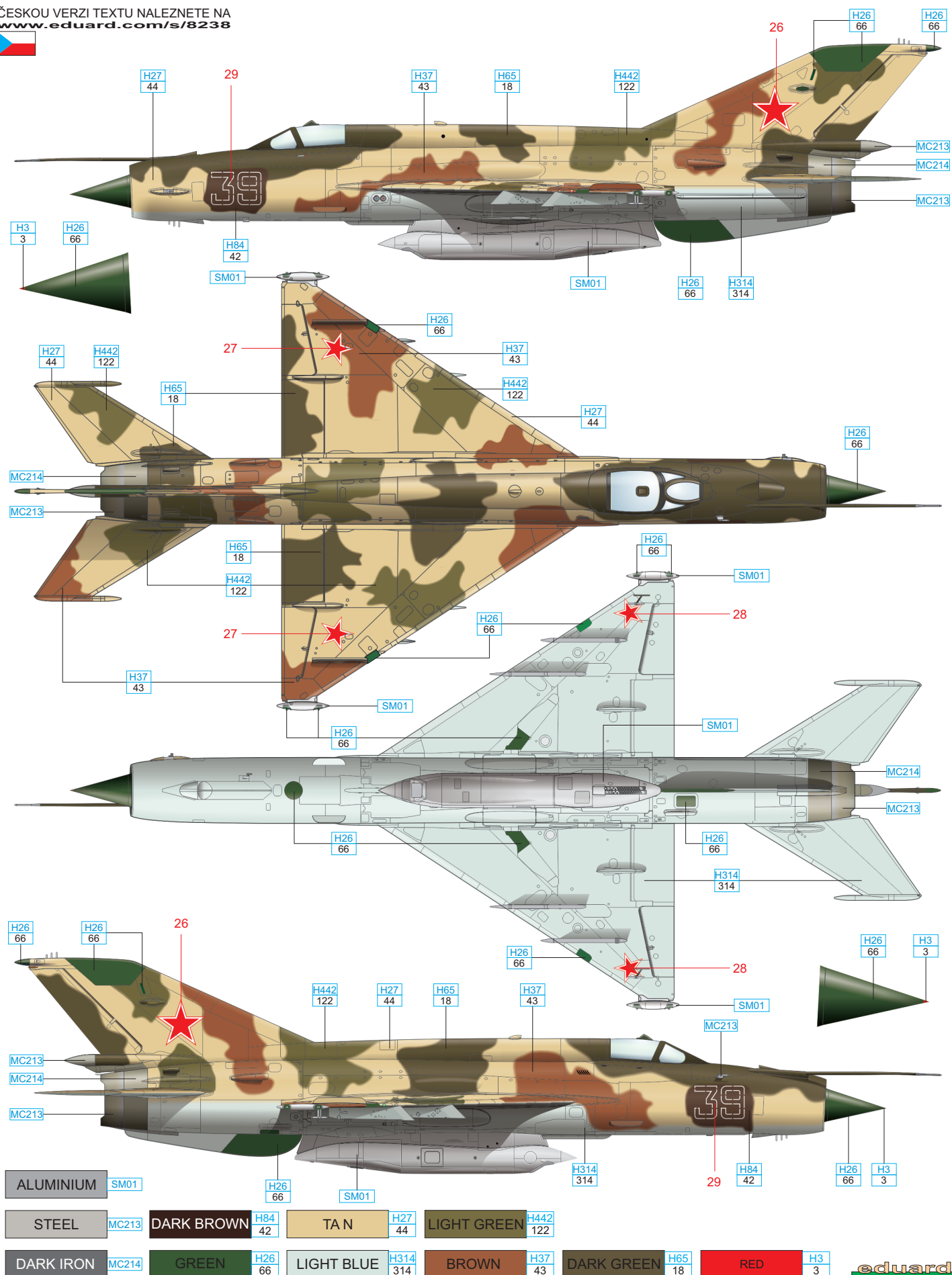

B 353rd Reconnaissance Air Squadron, Yugoslavia, 1971

The Yugoslav Air Force purchased a dozen MiG-21Rs from the Soviet Union. These were delivered either in 1968 or 1969 and served under the local type designation L-14I. The first user of Aircraft 26104 was the 126th Reconnaissance Squadron that flew all of the Yugoslav MiG-21Rs. This Squadron was a part of the 204th Fighter Air Regiment. The next users of this MiG were the 352nd and 353rd Reconnaissance Squadrons prior to being scrapped at Kraljevo. The white lightning appeared on the nose during 'Sloboda' military exercise in 1971.

ČESKOU VERZI TEXTU NALEZNETE NA
www.eduard.com/s/8238

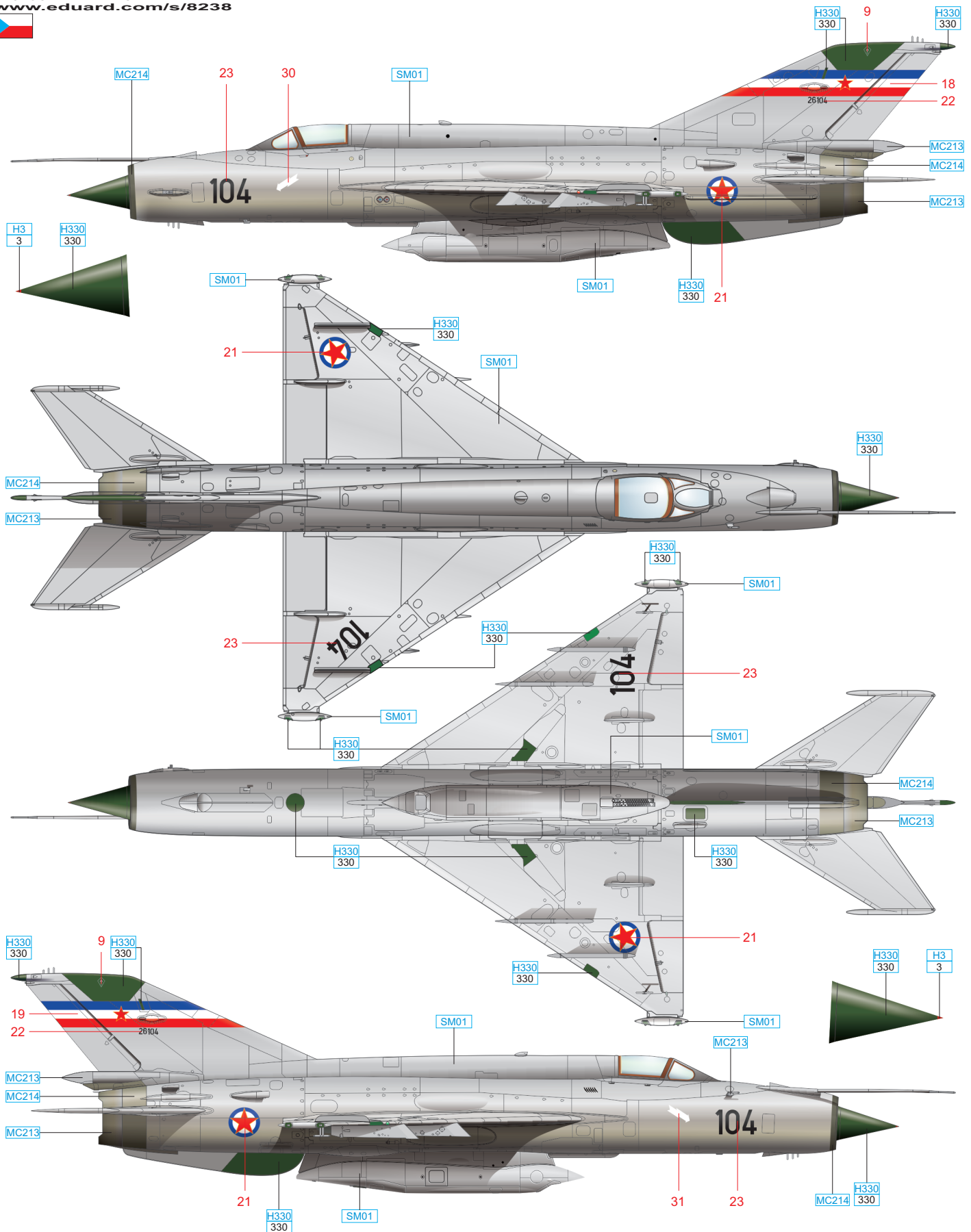

DARK IRON MC214 STEEL MC213 ALUMINIUM SM01 RED H3 3 GREEN H330 330



D Polish Air Force, 32nd Tactical Reconnaissance Air Regiment, Sochaczew – Bielice Air Base, Early 80s

MiG-21R s/n 94R011423 was delivered to Poland on September 29, 1968 along with another 'R'. These two MiGs were the first MiG-21Rs to arrive in Poland. '1423' was flown by the 41st Fighter Air Regiment based in Malbork Air Base. In a very short period of time, on July 8, 1969, the aircraft was overhanded by the 21st Tactical Reconnaissance Air Regiment and moved to Sochaczew. From December 1982 it entered the inventory of the 2nd Squadron, 32nd Tactical Reconnaissance Air Regiment. Service with this unit is symbolized by the squadron badge on the port side of the nose, while the starboard side sports the 32nd Tactical Reconnaissance Air Regiment unit badge. This MiG is preserved at the air museum in Drzonow Poland.

ČESKOU VERZI TEXTU NALEZNETE NA
www.eduard.com/s/8238

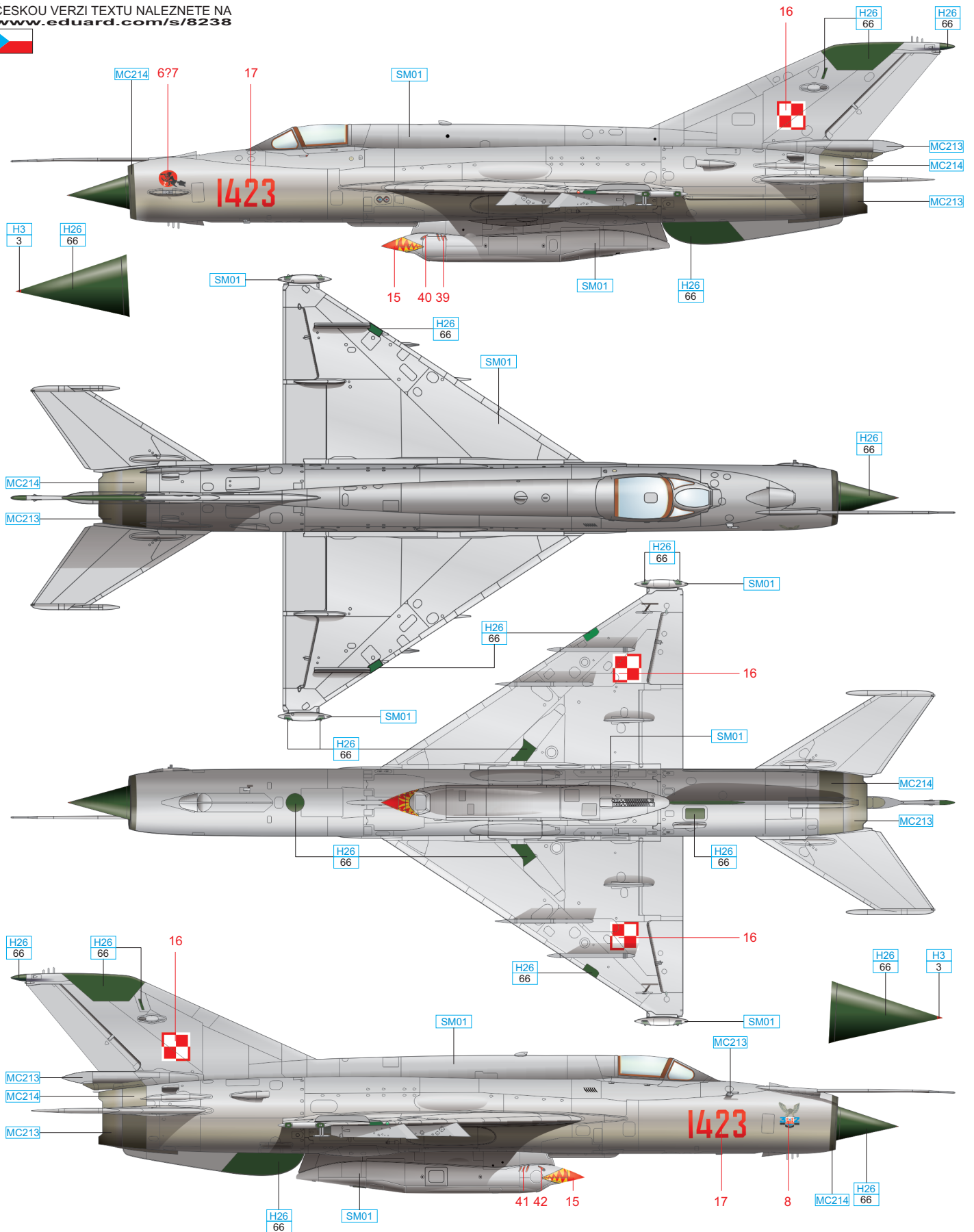

DARK IRON	MC214	STEEL	MC213	ALUMINIUM	SM01	RED	H3 3	GREEN	H26 66
-----------	-------	-------	-------	-----------	------	-----	------	-------	--------



ORIENTAČNÍ SCHÉMA ROZMÍSTNĚNÍ POPISEK

