



BMW 507 CABRIO

A 07200 - 0389

©1991 BY REVELL GmbH & Co. KG

PRINTED IN GERMANY

DEUTSCH-ACHTUNG: Vor dem Zusammensetzen die Bauanleitung gut durchlesen. Jedes Teil ist nummeriert. Reihenfolge der Montageschritte beachten. Benötigte Werkzeuge: Messer und Feile zum Entfernen und Entgraten der Teile, Gummiband, Klebeband und Wäscheklammern zum Zusammenhalten der geklebten Einzelteile. Plastikteile in einer milden Waschlösung reinigen und an der Luft trocknen, damit der Farbanstrich und die Abziehbilder besser haften. Vor dem Ankleben prüfen, ob die Teile passen; Klebstoff sparsam auftragen. Chrom und Farbe an den Klebeflächen entfernen. Kleine Teile anstreichen, bevor sie vom Rahmen entfernt werden. Farben gut durchtrocknen lassen, erst dann den Zusammenbau fortsetzen. Jedes Abziehbildmotiv einzeln ausschneiden und ca. 20 Sekunden in warmes Wasser tauchen. Das Motiv an der bezeichneten Stelle vom Papier abschieben und mit Löschpapier andrücken.

ENGLISH-ATTENTION: Carefully read instruction sheet before assembling. Each part is numbered. Consider succession of assembly steps. Required tools: knife and file to remove and trim parts; rubber band, adhesive tape and clothes pegs to hold parts after cementing. Wash plastic in mild detergent solution, rinse and let air dry for better paint and decal adhesion. Scrape chrome and paint at area to be glued: Paint small parts on runner before removing. Allow paint to dry thoroughly before continuing assembly. Cut out each decal one by one and dip it in warm water for approx. 20 secs.; slide decal from the paper at the marked position and dab with blotting-paper.

FRANCAIS-ATTENTION: lire soigneusement la fiche d'instructions avant d'assembler. Chaque pièce est numérotée. Suivre la succession des étapes de montage. Outils nécessaires: couteau et lime pour détacher et ébarber les pièces, élastiques, papier adhésif et pinces à linge pour maintenir ensemble les pièces après collage. Laver le plastique dans une solution détergente légère, rincer et laisser sécher à l'air libre pour une meilleure adhérence de la peinture et des décalés. Ajuster les pièces ensemble avant de coller. Employer la colle Revell pour plastique exclusivement. Utiliser très peu de colle à chaque fois. Grattez le chrome ou la peinture sur les surfaces à coller. Peindre les petites pièces sur le support avant de les détacher. Laisser la peinture sécher totalement avant de continuer l'assemblage. Découper chaque décal séparément et le plonger dans l'eau chaude environ 20 secondes. Faire glisser le décal du papier à l'endroit du décor et tamponner avec du papier buvard.

NEDERLANDS-OPGELET: alvorens te beginnen met het in elkaar zetten, eerst de handleiding goed doorlezen. Elk onderdeel is genummerd. Aandacht besteden aan de volgorde van montage. Het benodigde gereedschap: mesje en vijl voor het verwijderen en het afbramen van de onderdelen, elastiek, plakband en wasknijpers gebruiken voor het bij elkaar houden van de gelijmde onderdelen. De plastic onderdelen met een zacht wasmiddel schoonmaken en laten drogen zodat de verf en de transfers beter hechten. Alvorens te lijmen, eerst vaststellen of de onderdelen

passen; de lijm zuinig opbrengen. Chrom en verf van de op elkaar te lijmen delen verwijderen. Kleine onderdelen verven vóór deze van het gietraam verwijderd worden. De verf goed laten drogen en eerst dan verder gaan met de bouw. Elk transfer apart uitknippen en ca. 20 seconden in lauw/warm water leggen. Het transfer op de juiste plaats van het papier schuiven op het model en met vloeipapier aandrukken.

SVENSKA-VIKTIGT: Läs noggrant igenom instruktionerna innan du börjar bygga. Varje del är numrerad. Tänk igenom ordningsföljden för de olika momenten. Följande verktyg krävs: kniv och fil för att ta loss och putsa detaljerna, gummiband, tejp och klädnypor för att hålla detaljerna på plats medan limmet torkar. Tvätta alla plastdelarna i mild tvålösning, skölj och låt lufttorka för att få färg och dekalere att fästa bättre. Propassa alltid detaljerna innan du limmar. Använd endast Revells plastlim. Använd sparsamt med lim. Skrapa bort krom och färg från den yta som ska limmas: måla smådelarna innan du skär loss dem. Låt all färg torka ordentligt innan du fortsätter byggandet. Skär ut varje dekal för sig och blöt den i ljummet vatten i ungefär 20 sekunder, och låt dekalen glida av papperet och ner på det markerade läget: sug sedan försiktigt upp det mesta vattnet med läskpapper eller en tygtrasa.

ITALIANO-Attenzione: Leggere attentamente le istruzioni prima dell'assemblaggio. Ogni pezzo è numerato. Tener presente la successione delle fasi di assemblaggio. Attrezzi necessari: coltello e lima-per rimuovere e rifinire le parti elastiche nastro adesivo e spilli per tenere le parti dopo averle incollate. Lavare la plastica con un detergente delicato, sciacquare e lasciar asciugare all'aria per una migliore adesione della vernice e delle 'decal'. Accoppiare le parti da incollare. Usare solamente 'Revell plastic cement'. Usare poco collante. Gratteggiare la cromatura e la vernice nei punti da incollare. Dipingere i piccoli accessori sul supporto prima di rimuoverli. Far seccare bene la vernice prima di continuare nell'assemblaggio. Ritagliare una per una le 'decal' ed immergerle in acqua tiepida per circa 20 secondi. Applicare ogni 'decal' nella posizione segnata e tamponare con della carta assorbente.

ESPAÑOL-ATENCIÓN: cuidadosamente lean la hoja de instrucciones antes del montaje. Cada pieza es numerada, consideren la sucesión de las operaciones de montaje. Herramientas requeridas: cuchilla y lima para quitar y desbarbar las piezas, banda de caucho, cinta adhesiva y pinzas para sujetar las piezas, después de engomadas. Lavar el plástico en solución detergente suave, aclarar y dejar que se seque al aire para una mejor adhesión de la pintura y la calcomanía. Adaptar las piezas bien juntas antes de encolar. Solamente utilizar pegamento plástico Revell. Utilizar el pegamento cuidadosamente y sin exceso. Raspar el cromado y la pintura en la zona que ha de ser encolada: Pintar las piezas pequeñas giratorias antes de sacarlas. Dejar que la pintura se seque totalmente antes de continuar el montaje. Cortar cada calcomanía una por una y sumergirla en agua caliente durante aproximadamente 20 segundos. Deslizar la calcomanía del papel en la posición marcada y golpearla suavemente con el papel secante.

Form hergestellt und im Eigentum von Revell GmbH & Co. KG/Revell Monogram Inc. Widerrechtliche Nachahmungen werden gerichtlich verfolgt. Ce produit est propriété de la société Revell GmbH & Co. KG/Revell Monogram Inc. Toute utilisation ou duplication frauduleuse fera l'objet de poursuites en justice. Modelado y en propiedad de Revell GmbH & Co. KG/Revell Monogramm Inc. Imitaciones ilícitas serán perseguidas por la ley. Forma prodotta dalla Revell GmbH & Co. KG/Revell Monogram Inc. e di proprietà della stessa impresa, la quale procederà legalmente contro ogni imitazione abusiva. Malli on Revell GmbH & Co. KG/Revell Monogram Inc. valmistama ja omaisuutta. Laittoaman kopiointiin tullaan puuttamaan oikeudelliset toimin. Formen er produsert og eies av Revell GmbH & Co. KG/Revell Monogram Inc. Etterligging uten tillatelse vil bli gjenstand for rettslig forfølgelse. Produkcja i prawa własności firmy Revell GmbH & Co. KG/Revell Monogram Inc. Nielegalne podrobienie jest zabronione pod odpowiedzialnością sądowną. Model, Revell GmbH & Co. KG/Revell Monogram Inc. firmasinn müliketel allinda imal edimistic. Kanuna aykin taktiler mahkemace takir edilecektir. A forma előállításja és a tulajdonjog birtokosa a Revell GmbH & Co. KG/Revell Monogram Inc. A jogellenes utánzatokat és hamisítványokat bíróságiag üldözök.

Model manufactured by and property of Revell GmbH & Co. KG/Revell Monogram Inc. Illegal imitations are subject to prosecution. Vorm vervaardigd door en eigendom van Revell GmbH & Co. KG/Revell Monogram Inc. Onrechtmatige nabootsingen worden gerechtelijk vervolgd. Formas produzidas e de propriedade da Revell GmbH & Co. KG/Revell Monogram Inc. Cópias não autorizadas serão processadas juridicamente como determinado na lei. Modellerna tillverkad av och tillhör Revell GmbH & Co. KG/Revell Monogram Inc. All kopiering beivras enligt lagen om upphovsrätt. Formen er fremstillet af Revell GmbH & Co. KG/Revell Monogram Inc. som også har ejendomsret. Lovstridige efterligninger sagsøges. Модель изготовлена и является собственностью фирмы Revell GmbH & Co. KG/Revell Monogram Inc. Протизаконные подделки преследуются в судебном порядке. Η μορφή κατασκευάστηκε και περιέχεται στην ιδιοκτησία της Revell GmbH & Co. KG/Revell Monogram Inc. Οι παράνομες μιμήσεις θα καταδιωκτούν δικαστικώς. Tiar byt vyhotren firmou Revell GmbH & Co. KG/Revell Monogram Inc. a je jich vlastnictvím. Proti nezákonným napodobením sa bude postupovať súdne cestou. Forma je proizvedena in je vlasništvo Revell GmbH & Co. KG/Revell Monogram Inc. Neovlaštene kopije bodo pravno kaznjene.



Kleben
Glue
A coller
Lijmen
Limmas
Incollare
Engomar



Nicht kleben.
Don't glue.
A ne pas coller.
Niet lijmen.
Timmas ej.
Non incollare.
No engomar.



Anzahl der Arbeitsgänge.
Number of working steps.
Nombre d'étapes de travail
Het aantal der bouwhandelingen.
Antal arbetsmoment.
Numero di passaggi.
Numero de operaciones de trabajo.



Wahlweise
Optional
Facultatif
Ter keuze
Valfritt
Facoltativo
Opcional

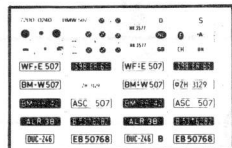

Abziehbild in Wasser einweichen und anbringen.
Soak and apply decals.
Mouiller et appliquer les décalés.
Transfer in water even laten weken en opbrengen.
Blöt och fast dekalerna.
Immergere in acqua ed applicare decal.
Remojar y aplicar las calcomanías.



Abbildung zusammengebauter Teile.
Shown assembled.
Vu assemblé.
Afbeelding van een gebouwd onderdeel.
Visas hopsatt.
Figura assemblata.
Presentado montado.



Klarsichtteile
Clear parts
Pièces transparentes
Transparante onderdelen
Genomskinliga detaljer
Parte trasparente
Limpias las piezas



MATT BLACK
MATT SCHWARZ 8
NOIR MAT
MAT ZWART
MATT ZWART
NERO SMORTO



WHITE
WEISS 4
BLANC
WIT
VIT
BIANCO



BLACK
SCHWARZ 7
NOIR
ZWART
SWART
NERO



ALUMINIUM
ALUMINIUM 99
ALUMINIUM
ALUMINIUM
ALUMINIUM
ALUMINIUM



METALLIC GREY
EISENFARBIG 91
GRIS METALLIQUE
IJZERKLEUR
JARGNRA
FERRO



BRONZE
BRONZE 95
CLAIRE ORANGE
BRONS
BRONS
BRONZO



CLEAR ORANGE
KLAR ORANGE 730
CLAIRE ORANGE
DOORZICHTIG ORANJE
KLAR ORANGE
CHIARO ARANCIONE



CLEAR RED
KLAR RÖT 731
CLAIRE ROUGE
DOORZICHTIG ROOD
KLAR RÖD
CHIARO ROSSO



BLACK
SCHWARZ 302
NOIR
ZWART
SWART
NERO



FIERY RED
FEUERROT 330
ROUGE VERMILLON
VUURROOD
ELDROD
ROSSO ACCESSO



CARMIN RED
KARMINROT 36
ROUGE CARMIN
KARMINROOD
KARMINROD
ROSSO CARMINIO



DUST GREY
STAUBGRAU 77
GRIS POUSSIÈRE
STOFGRIJS
DAMMGRÄ
GRIGIO SABBIA



MATT BRICK RED
MATT ZIEGELROT 37
ROUGE FONCE MAT
MAT DONKER ROOD
MATT WOKK ROOD
ROSSO SCURO SMORTO



MATT YELLOW
MATT GELB 15
JAUNE MAT
MAT GEEL
MATT GUL
GIALLO SMORTO

1 

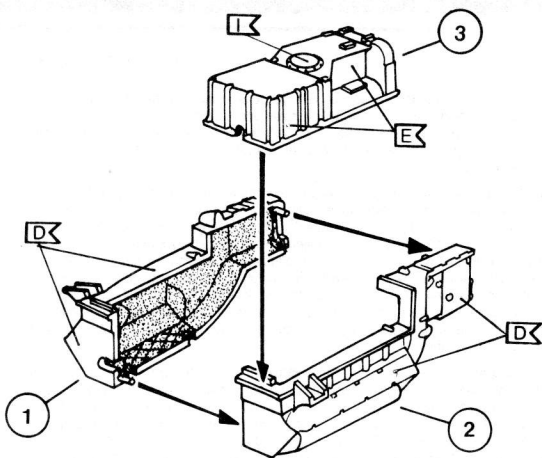

2 

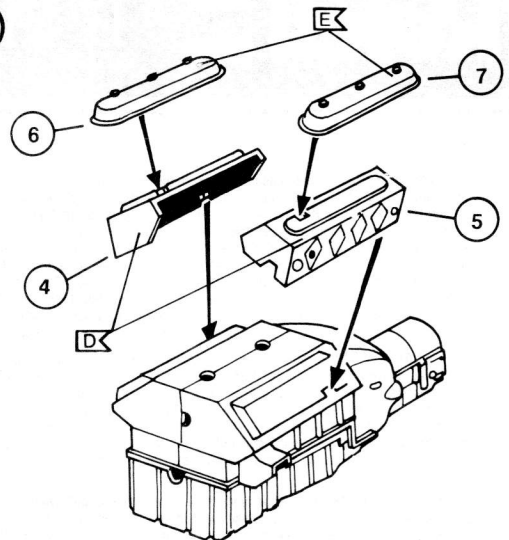

3 

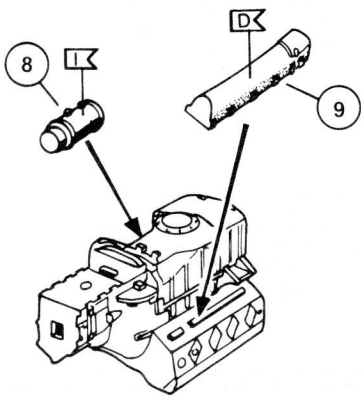

4 

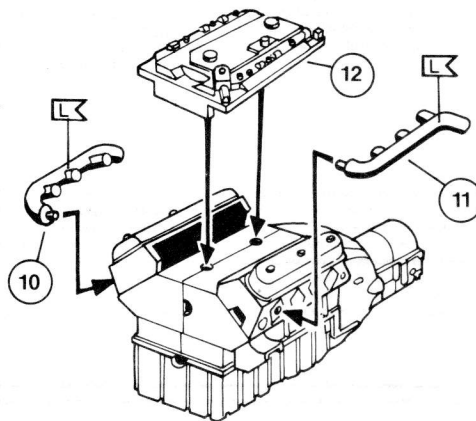

5 

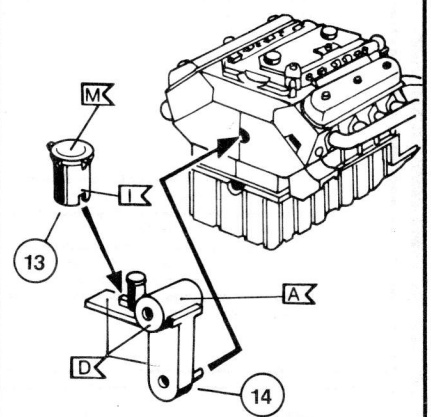

6 

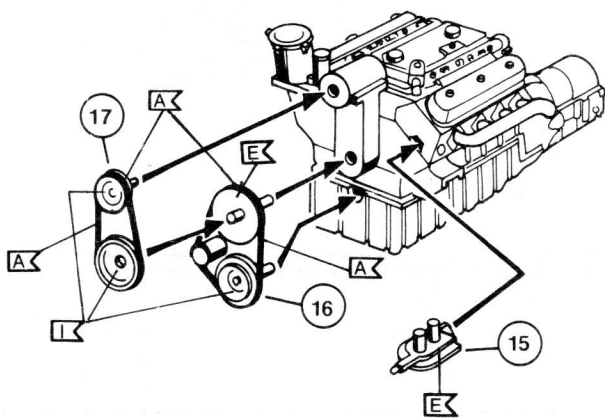

7 

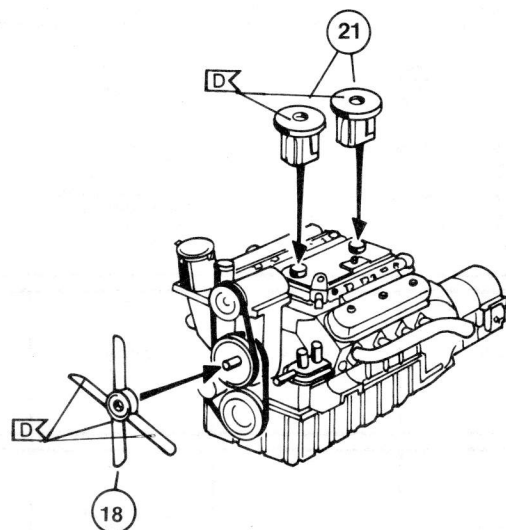

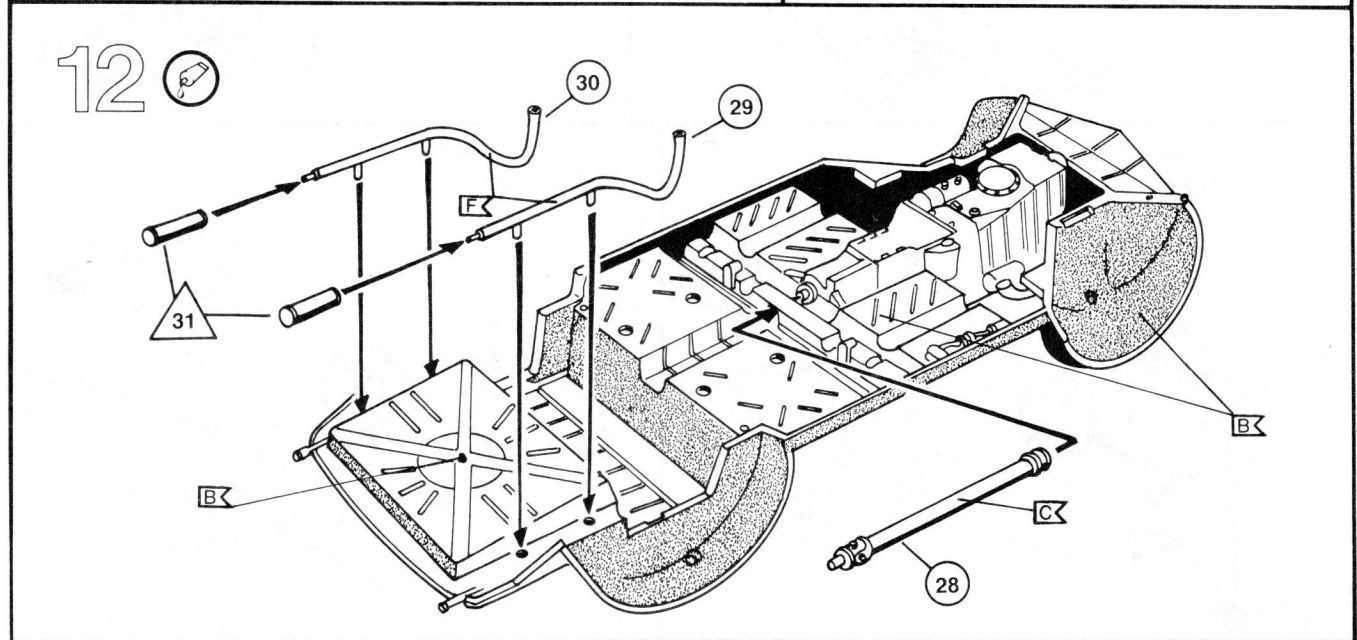
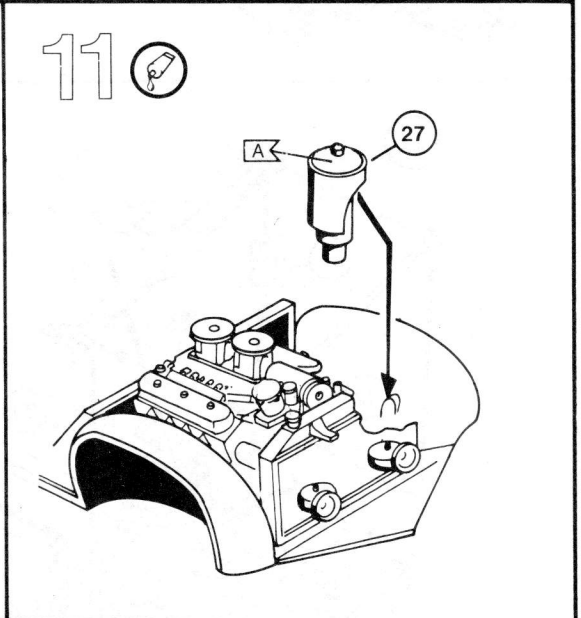
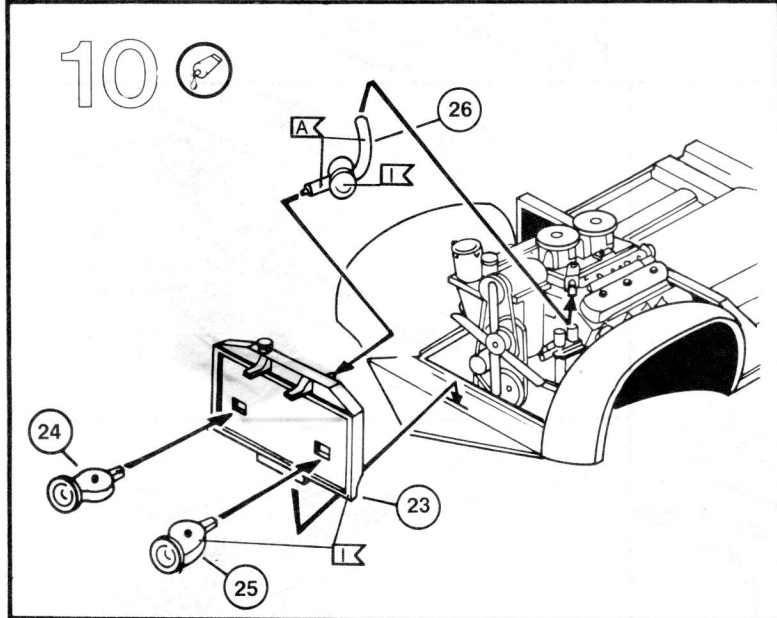
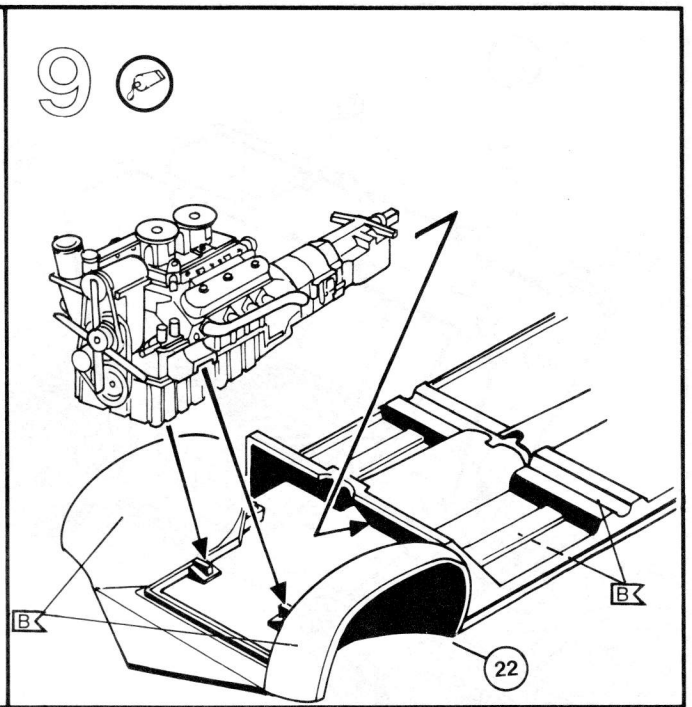
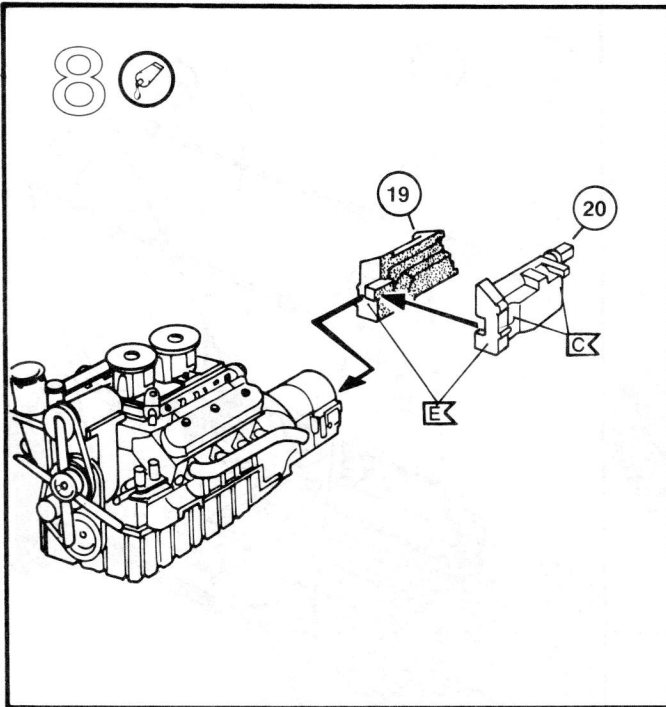

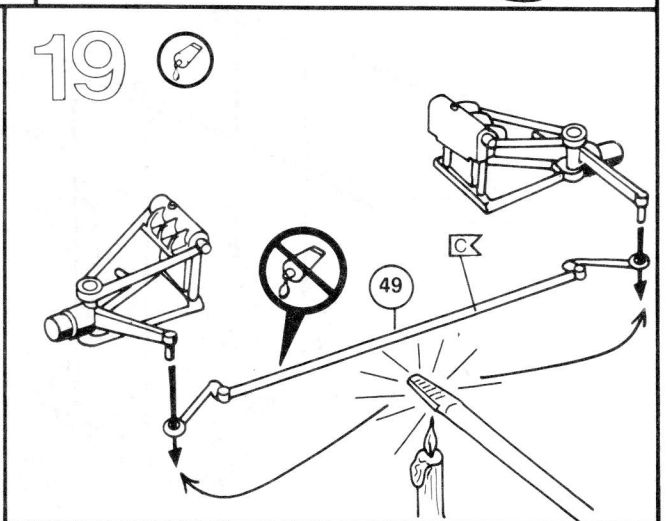
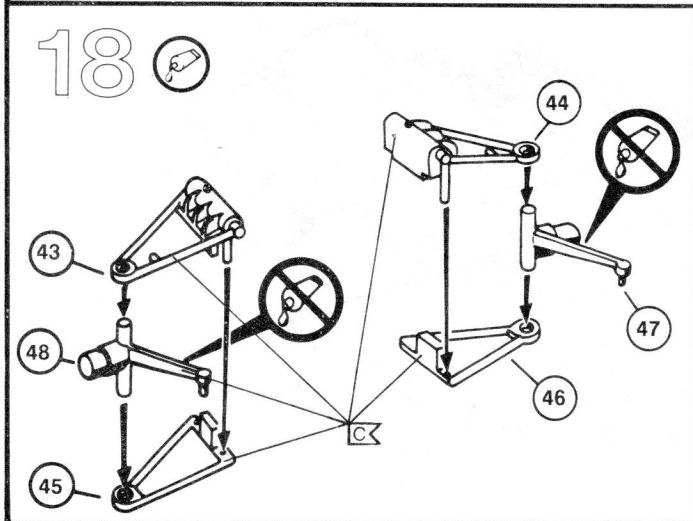
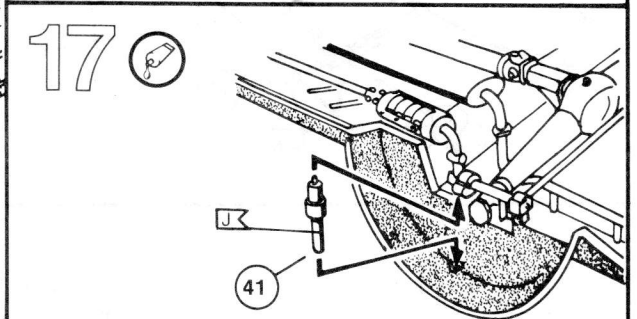
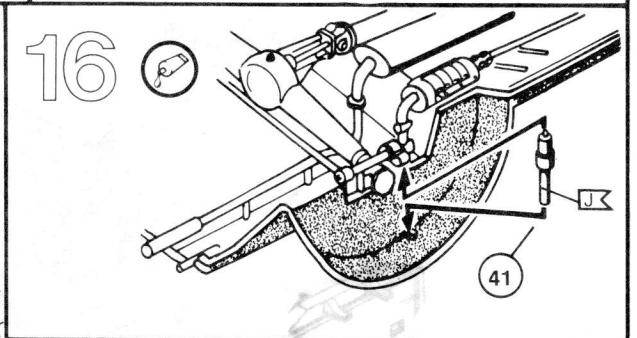
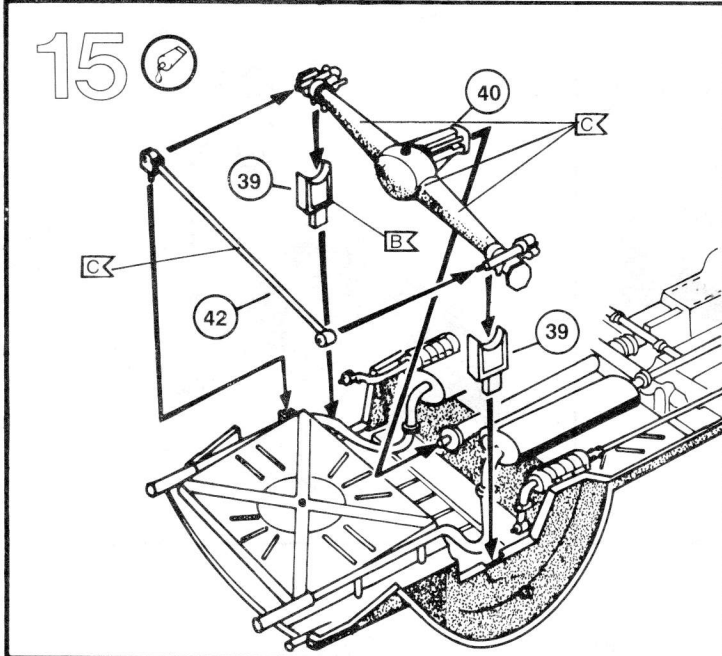
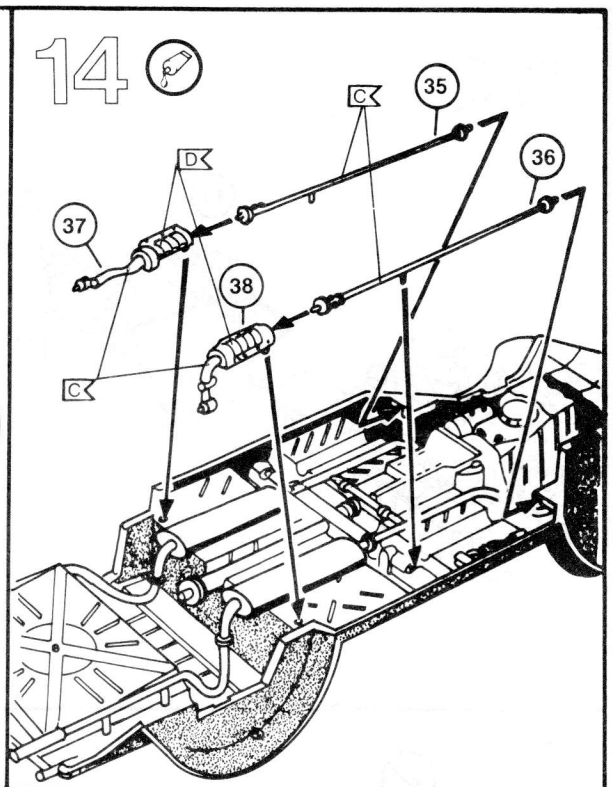
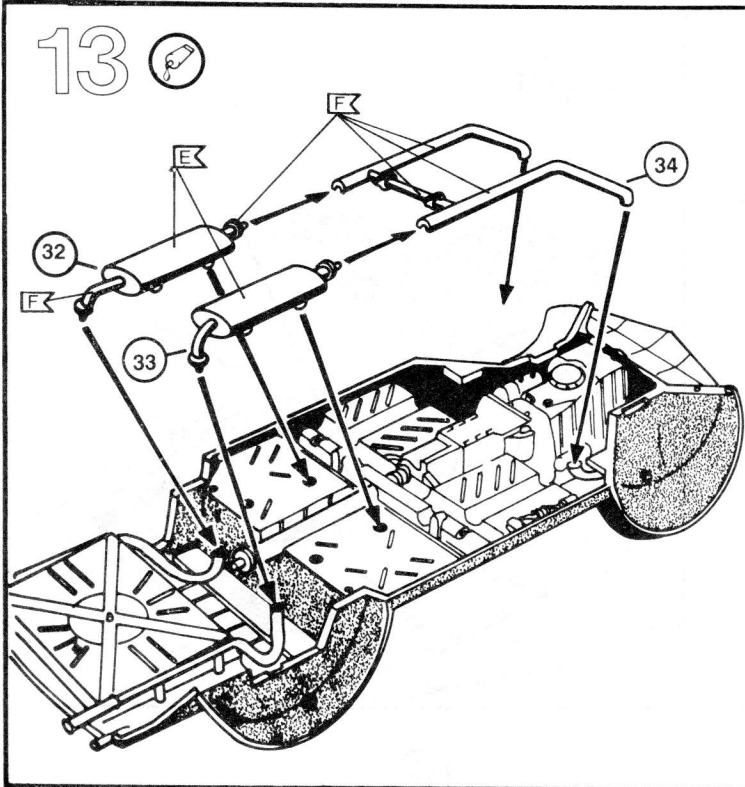

20 

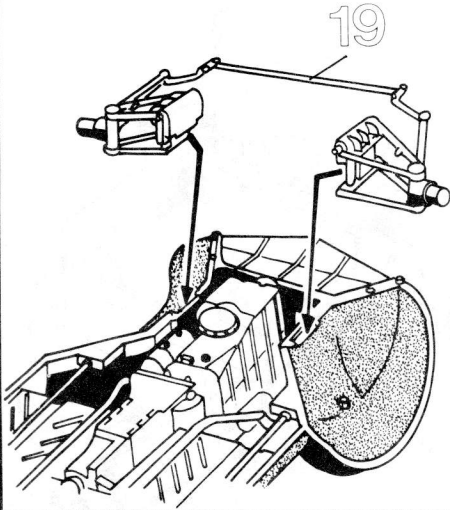

21 

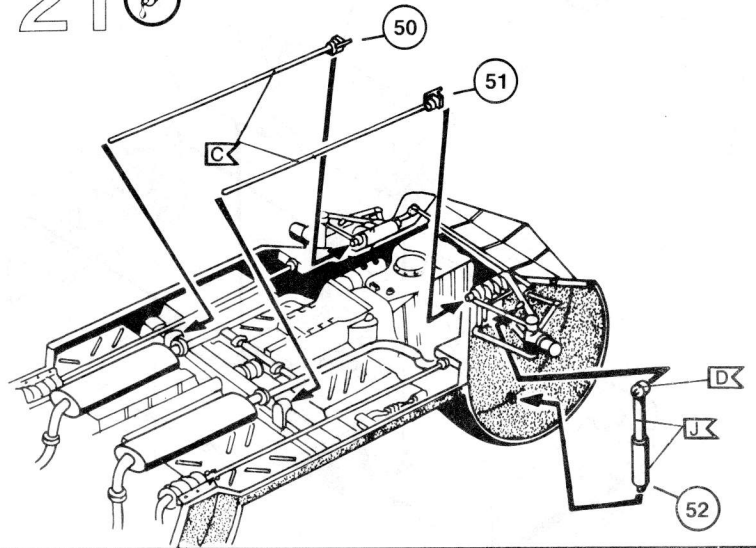

22 

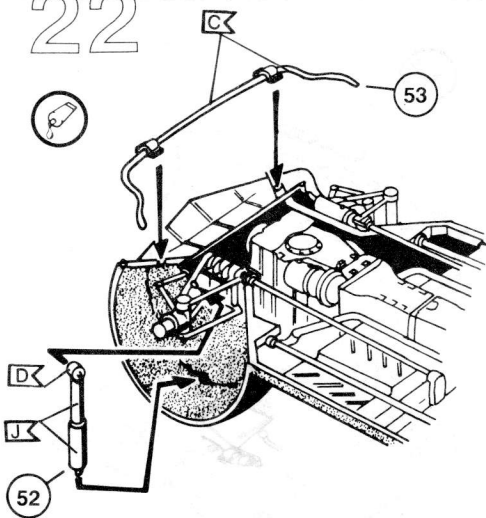

23 

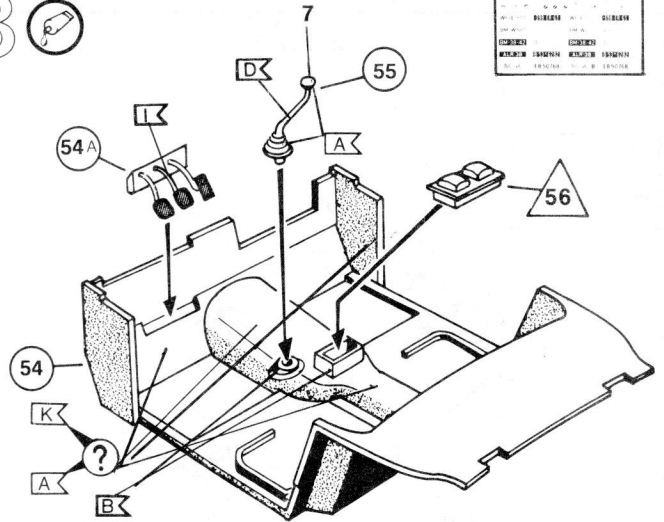

24 

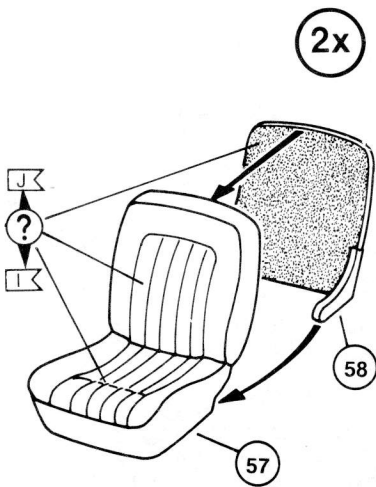

25 

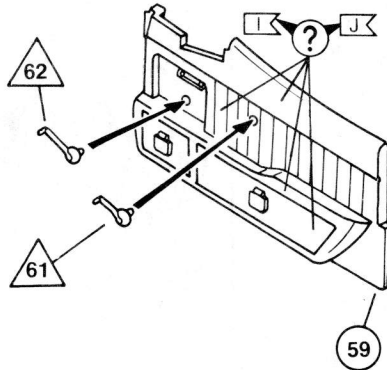

26 

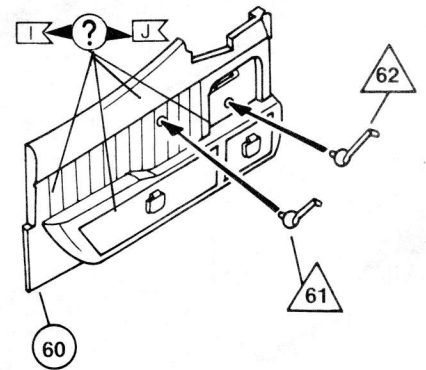

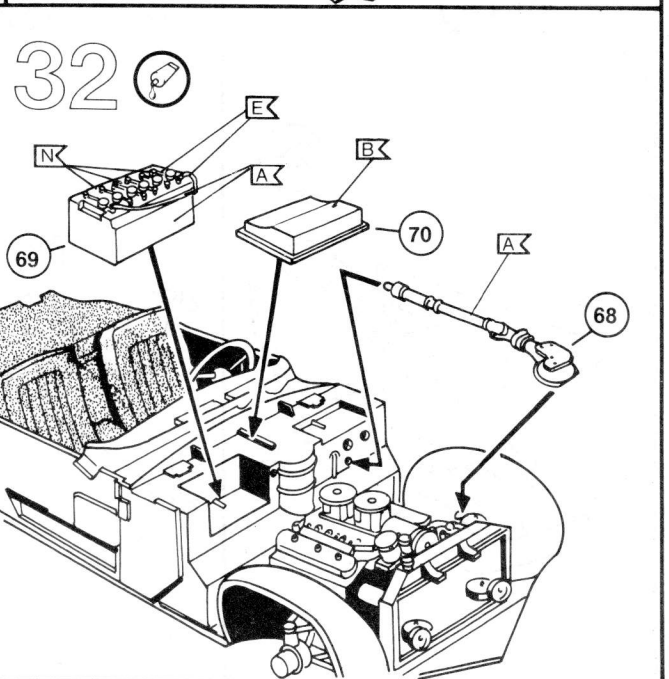
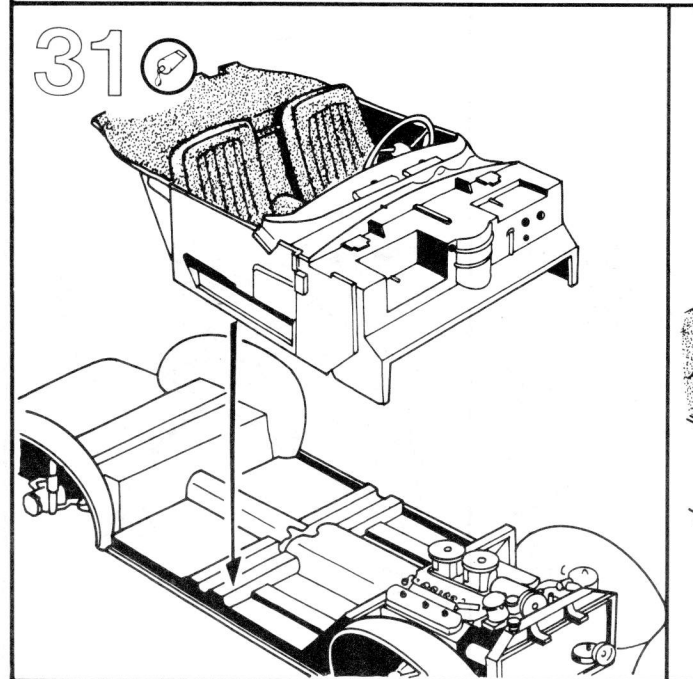
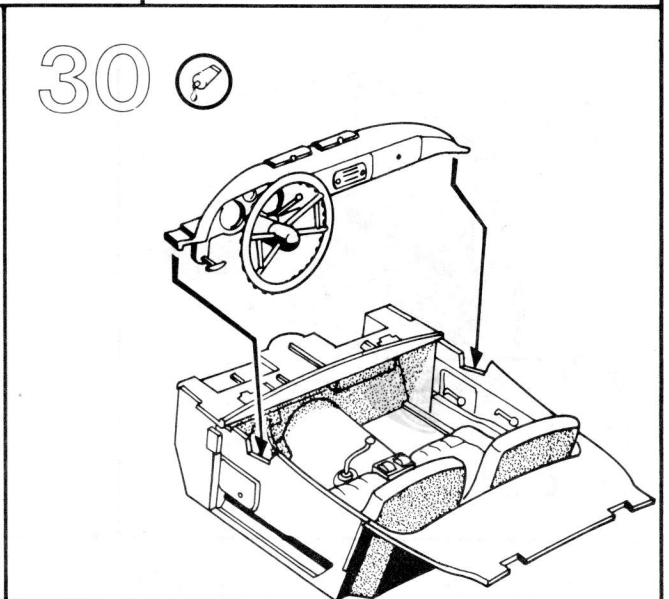
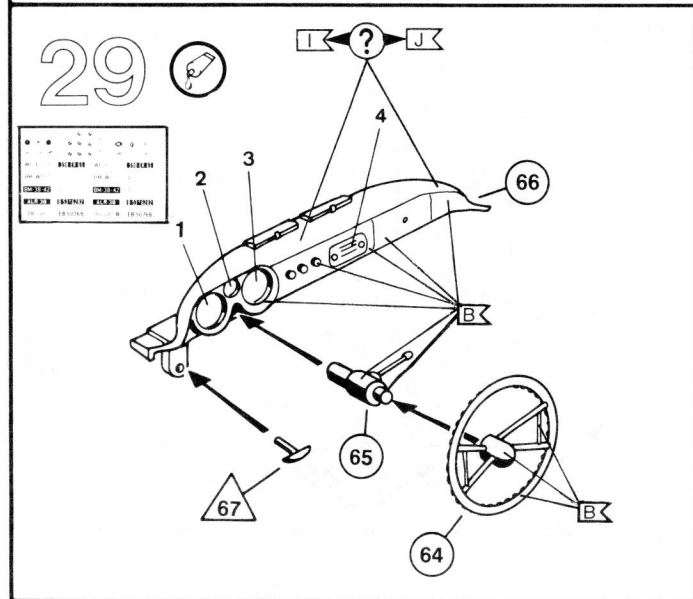
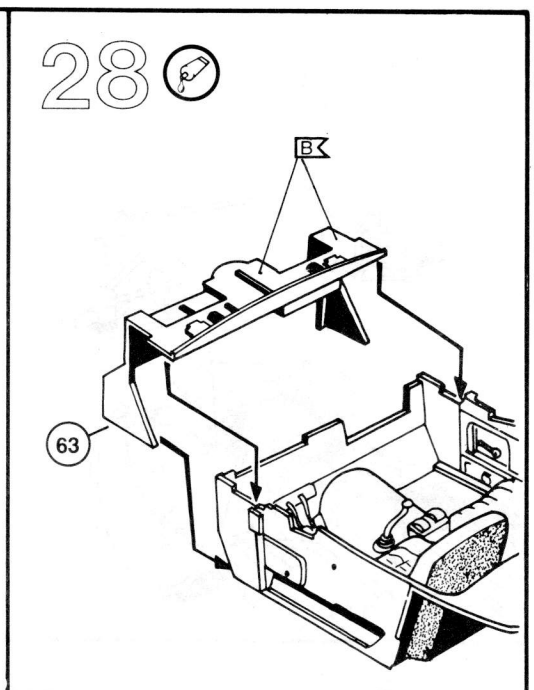
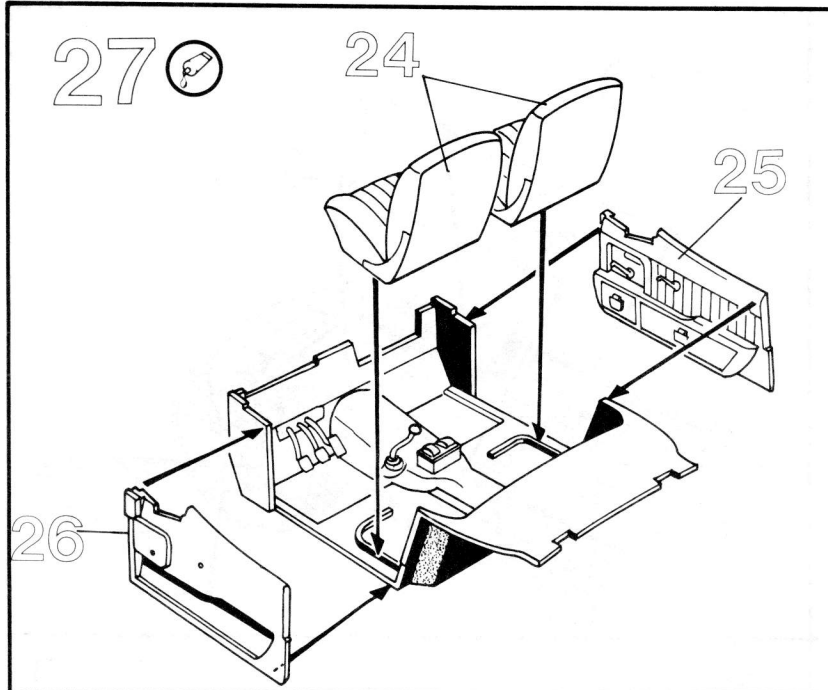

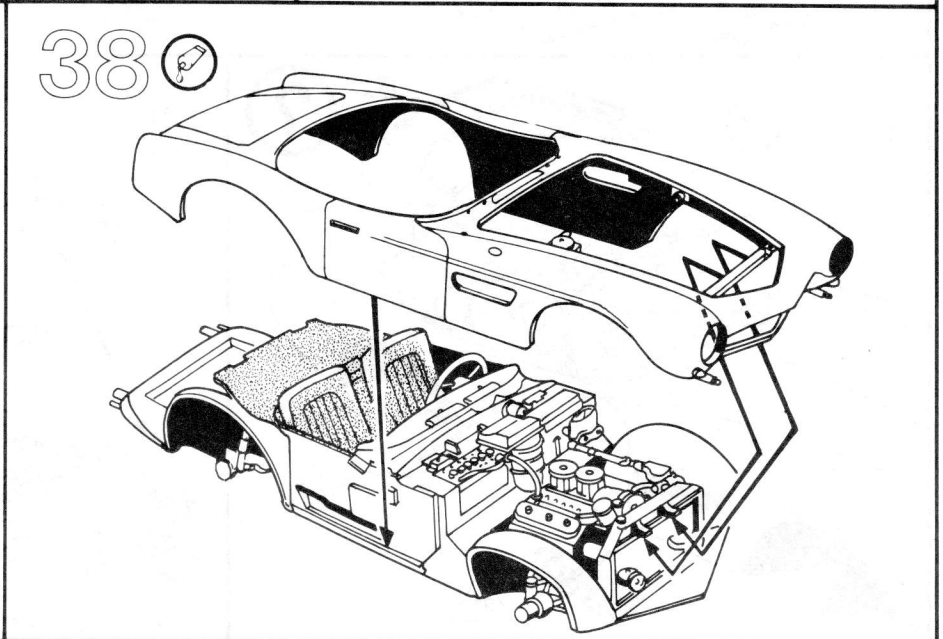
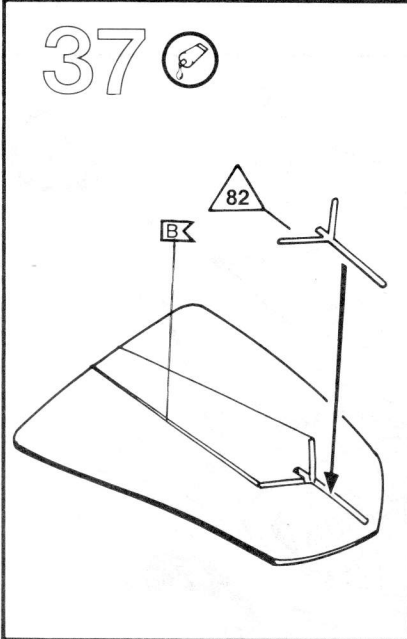
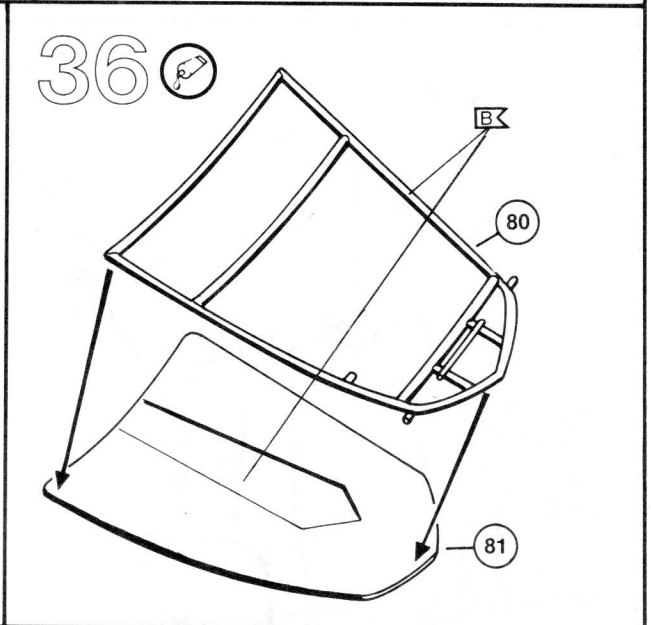
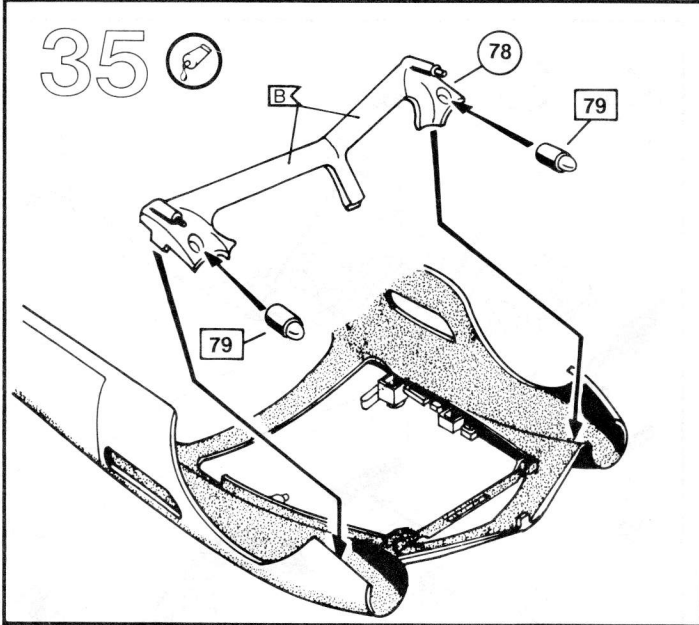
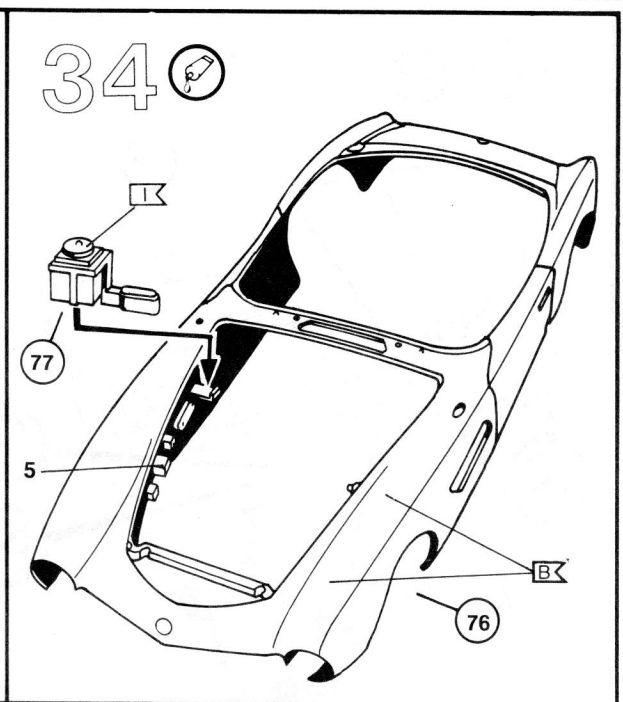
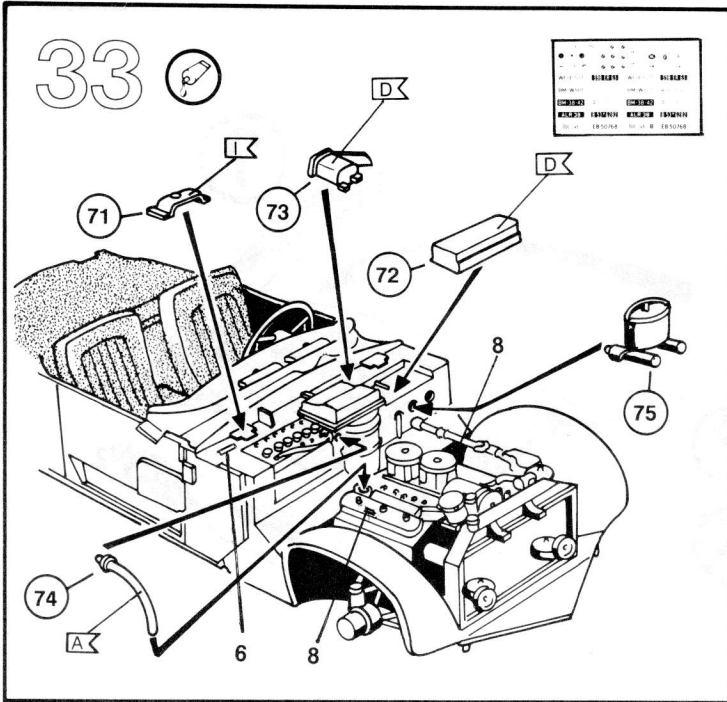

39

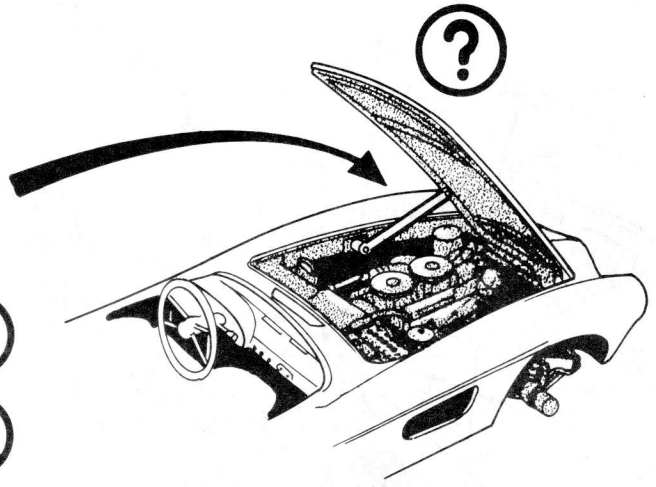
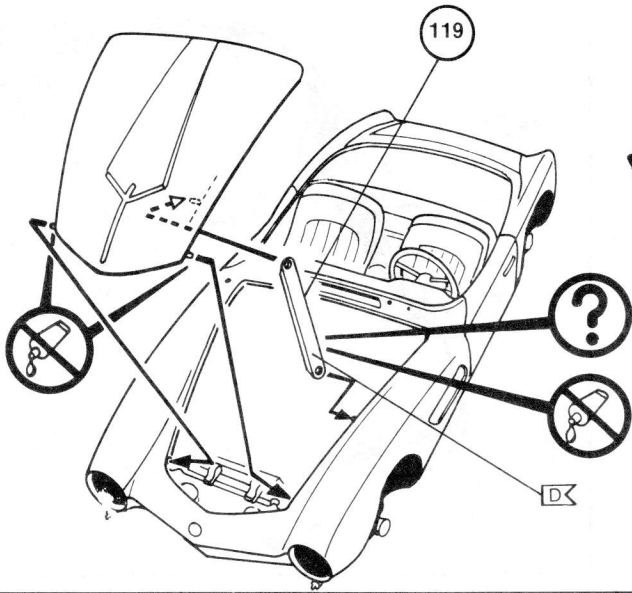

40

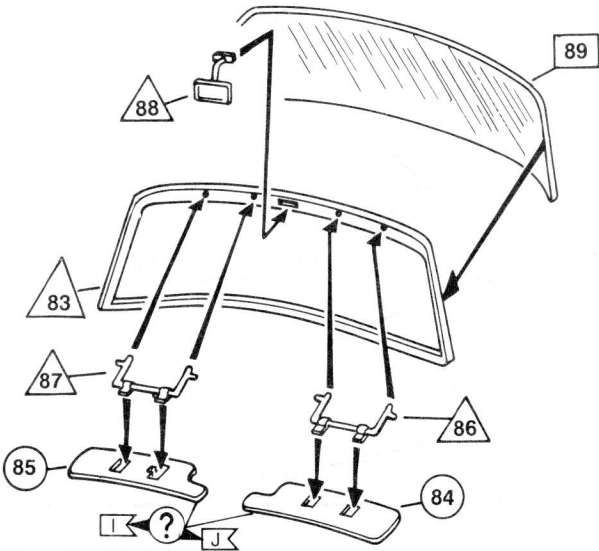

41

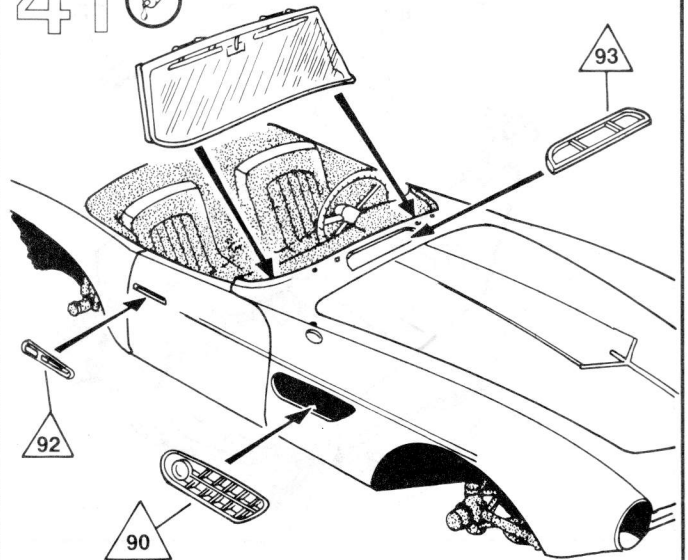

42

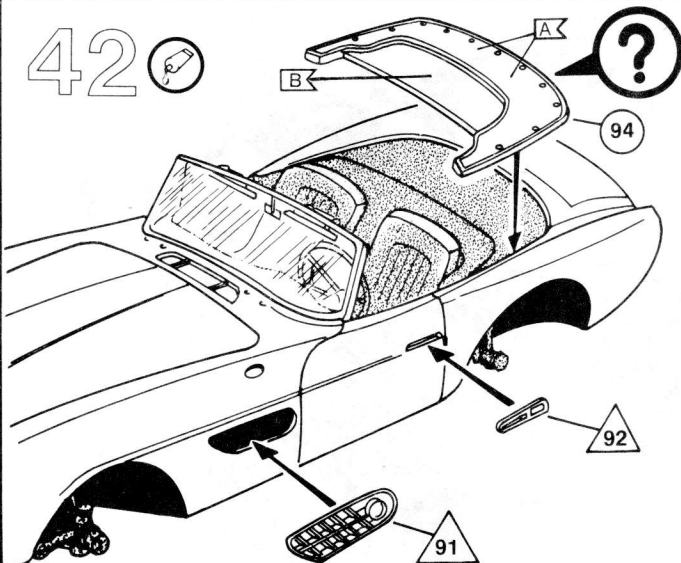

43

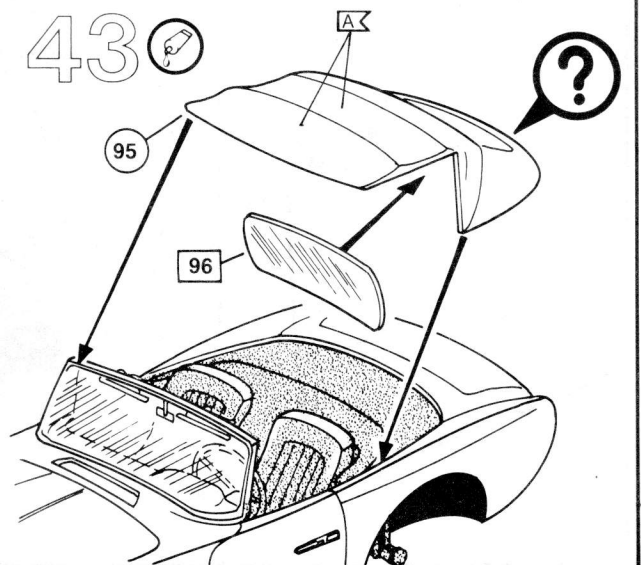

44

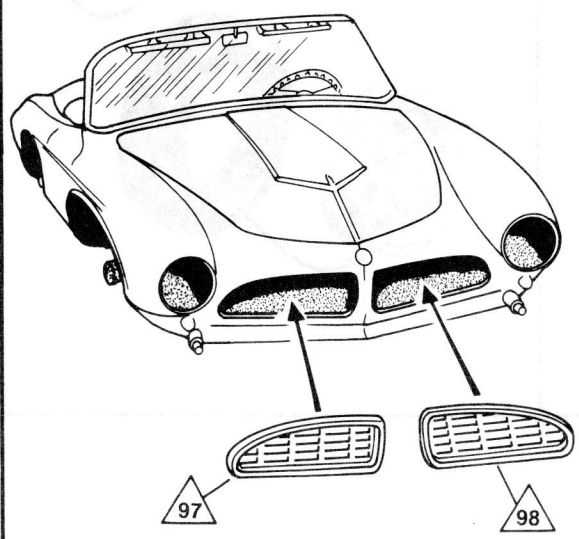

45

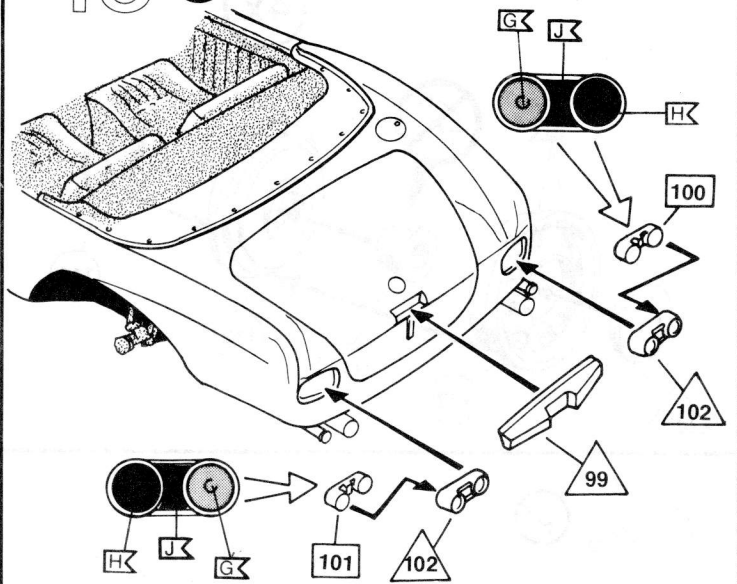

46

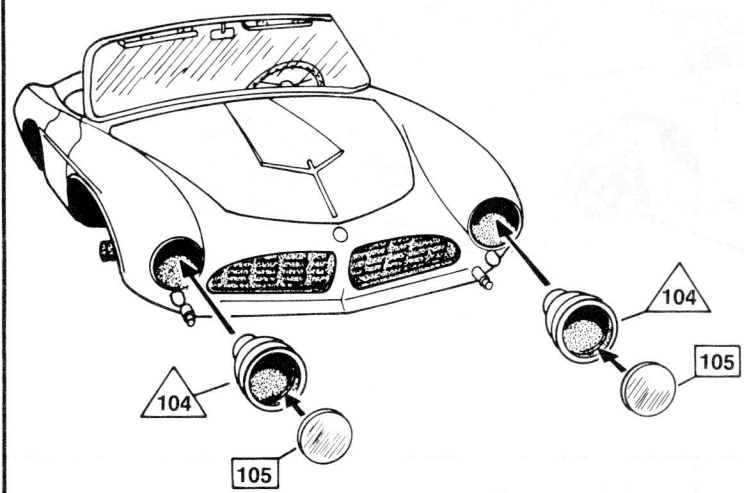

47

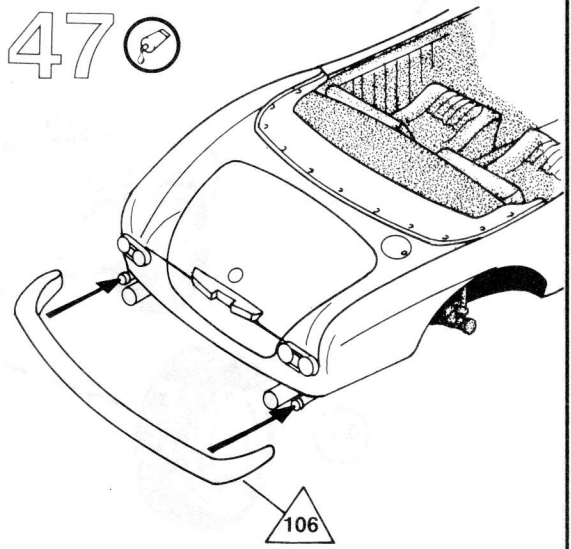

48

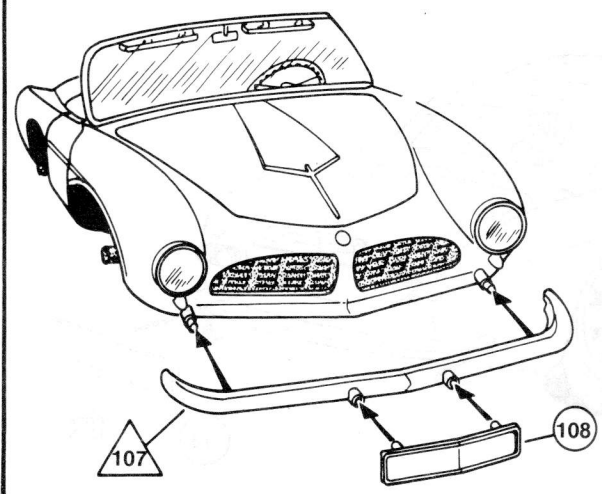

49

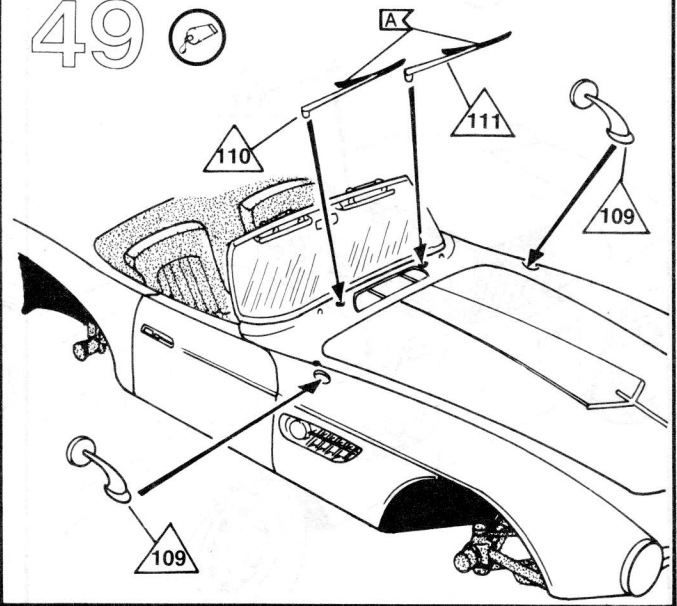

50 

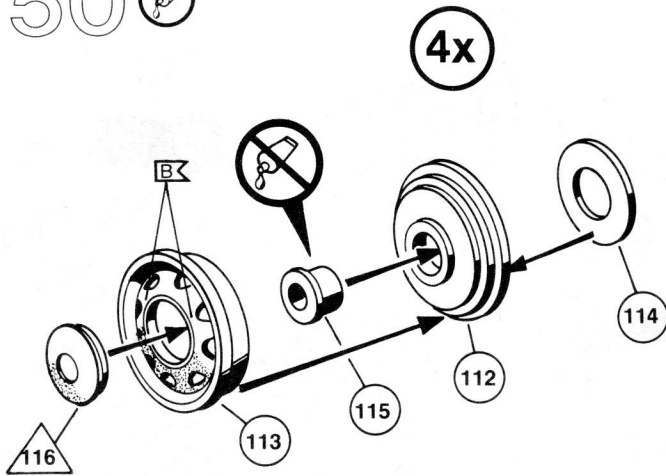

51 

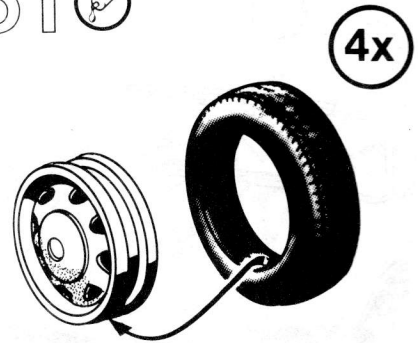

52 

4x

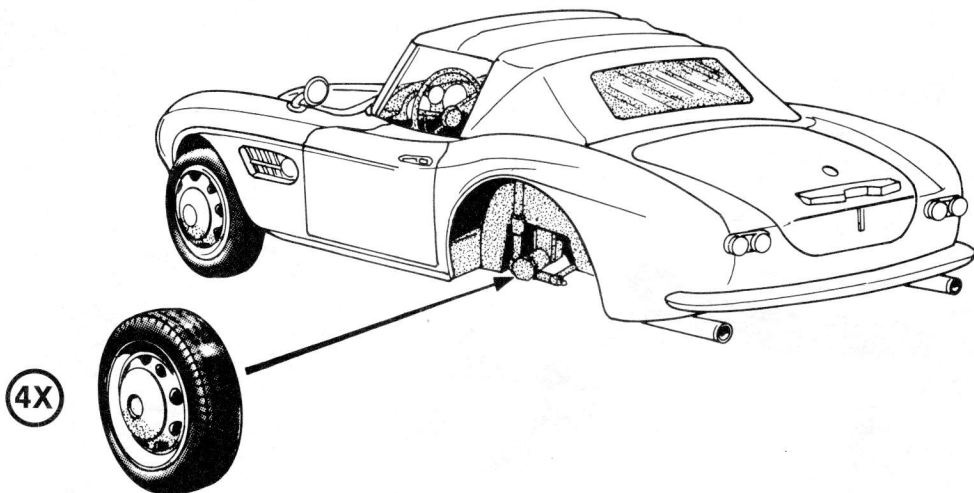

53 

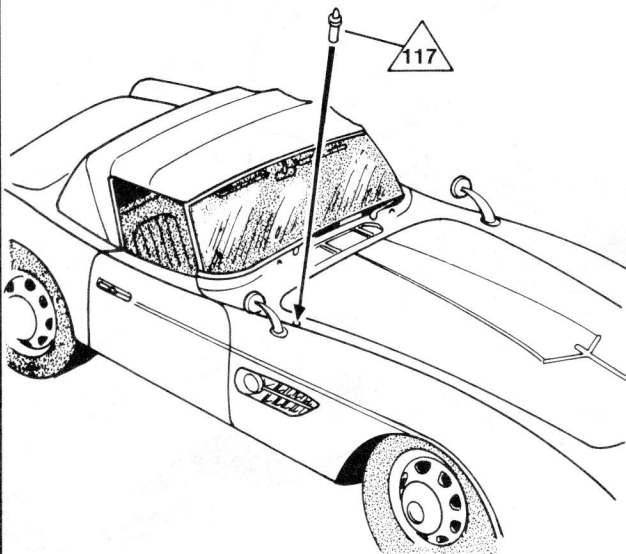

54 

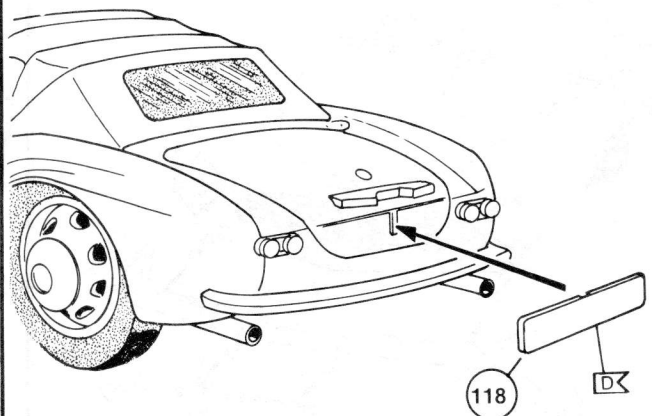

55

2700 (2740)	BMW 507	5
WF-E 507	WF-E 507	
BM-W 507	BM-W 507	
ASC 507	ASC 507	
EB 50768	EB 50768	

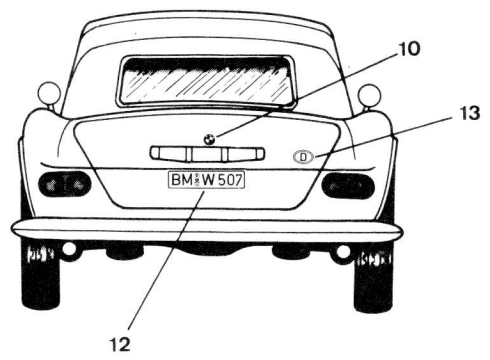
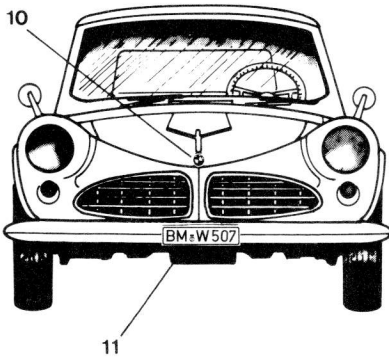
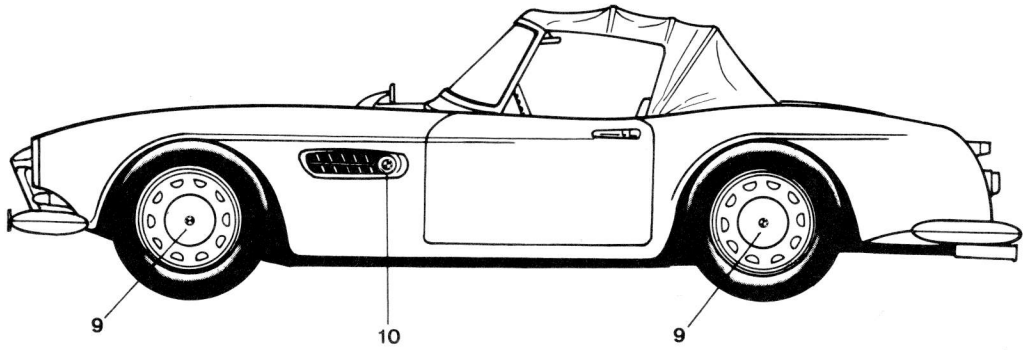

Dieser Bausatz wurde in mehrfachen Qualitäts- und Gewichtskontrollen auf Vollständigkeit überprüft. Reklamationen können nur bearbeitet werden, wenn die Bauanleitung, das aus der Kartonage herausgeschnittene EAN-Strichcode-Feld und der Kassenbon eingeschickt werden. Bitte haben Sie Verständnis dafür, dass wir nur Gewährleistung bei aktuellen Artikeln übernehmen können, die im Zeitraum der letzten 24 Monate erworben worden sind. Unfrei eingesandte Reklamationssendungen werden von uns nicht angenommen!
„Einzelteile für Umbauten können gegen Vorkasse erworben werden“. Unsere Adresse: Revell GmbH & Co. KG, Abteilung X, Henschelstr. 20-30, 32257 Bünde. Dieser Direktservice gilt für die Länder: Deutschland, Benelux, Österreich, Frankreich, Großbritannien. Reklamationen aus den übrigen Ländern werden über die jeweiligen Distributeure abgewickelt. Bitte kontaktieren Sie Ihren Händler.

This Model Kit has been subject to extensive quality and weight checks during the manufacturing process to ensure it leaves our warehouse in perfect condition. We are only able to process applications for missing parts if the following procedure is followed. In all cases the following will be required before we are able to process any request: Original receipt (proof of purchase) original instruction sheets (will be returned) and the bar code cut out of the box. We may not be able to process requests for products that have been discontinued for more than 24 months. Products that are returned directly to us without prior authorisation by a company representative will not be accepted and returned to sender. Replacement parts for conversion or spares will continue to be available however they will incur a handling charge. Please write to: Department X Revell GmbH & Co. KG, Henschelstr 20-30, 32257 Bünde.
This direct Service is only available in the following markets: Germany, Benelux, Austria, France & Great Britain, Revell GmbH & Co. KG, Boston Houso, 64-66 Queensway, Hemel Hempstead, Herts, HP2 5HA, Great Britain.

For all other markets please contact your local dealer or distributor directly.

Afin de vous donner entière satisfaction et pour nous assurer que tous les éléments nécessaires au montage de votre maquette sont présents dans la boîte, cet article a subi dans son intégralité divers contrôles qualitatifs ainsi que des contrôles de poids.

Si toutefois vous deviez nous faire part de certaines réclamations, nous vous prions de bien vouloir vous adresser à votre revendeur habituel, muni de la notice de montage, du code EAN découpé sur la boîte, ainsi que de votre ticket de caisse.

Le SAV ne sera assuré que pour les articles ayant été acquis depuis moins de 24 mois.

Les pièces de rechange utilisées pour la transformation de maquettes pourront être obtenues en pré-paiement. Dans le cas où vous n'obtiendriez pas satisfaction, vous pouvez vous adresser directement à notre service SAV à l'adresse suivante: REVELL GmbH & Co. KG, Abteilung X, Henschelstraße 20-30, D-32257 Bünde ou Revell GmbH & Co. KG, 14 B, rue du Chapeau Rouge, F-21000 Dijon, France.

Pour tous les autres marchés, merci de prendre contact avec votre détaillant ou distributeur.

Deze bouwdoos werd verscheidene malen volledig gecontroleerd op kwaliteit en gewicht. Klachten kunnen slechts in behandeling worden genomen indien de bouwhandleiding, de uit de doos geknipte EAN - streepjescode en de kassabon zijn meegezonden. Wij vragen om uw begrip dat wij alleen garantie kunnen geven voor huidige artikelen die binnen een periode van de laatste 24 maanden zijn gekocht. Onvolledig ingezonden klachten kunnen niet in behandeling worden genomen. Onderdelen voor ombouw kunnen tegen vooruitbetaling gekocht worden.

Ons adres is: Revell GmbH & Co. KG, Afdeling X, Henschelstrasse 20-30, 322557 Bünde. Duitsland. Deze directe service geldt alleen voor de volgende landen: Duitsland, Benelux, Oostenrijk, Frankrijk, Groot Brittannië.

Klachten afkomstig uit overige landen worden via de eventuele lokale vertegenwoordigers van Revell afgewikkeld. Wij verzoeken U contact op te nemen met uw winkelier.