

RS
MODELS

1:72 SCALE
92213

BFC-2 Goshawk Curtiss

On 16 April 1932, the US Navy ordered two prototypes of a new shipboard fighter under the designations XF11C-1 and XF11C-2, with a 700hp Wright R-1820-78 radial. The R-1820-78 Cyclone and mixed structure of the XF11C-2 found favour with the US Navy, and, on 18 October 1932, a production order was placed for 28 F11C-2s, deliveries of which began in February 1933 and were completed in the following May. The fourth aircraft on the contract was completed with a manually-retractable undercarriage as the XF11C-3, subsequently being redesignated XBF2C-1 with adoption of the "bomber-fighter" category in March 1934. Simultaneously, the F11C-2s were redesignated as BFC-2s. Armament comprised two 7.62mm Browning machine guns and a single bomb of up to 227kg or four 51kg bombs could be carried. The BFC-2 remained in US Navy service until 1938.

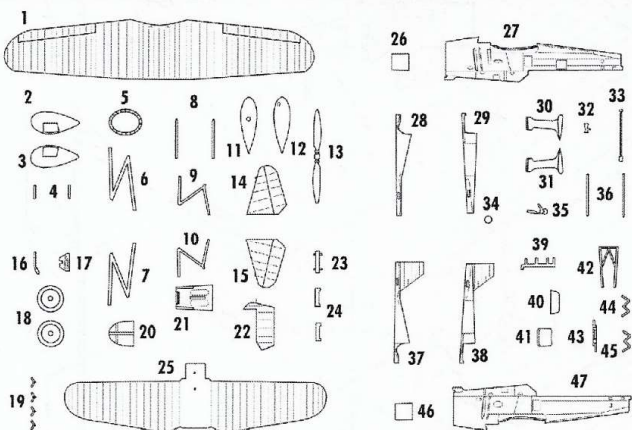

- ohnout bend
- vstřínové lepidlo cyanoacrylate glue
- odstranit remove
- upravit reduce
- vrtat open hole
- vyrobit scratch build
- obtlisk decal
- barva color
- film

POLYURETHAN PARTS (PUR)

CLEAR PARTS (CP)

PHOTO-ETCHED PARTS (PP)

COLORS

Černá Black	Červená Red
Lesklá černá Glass Black	Bílá White
Stříbrná Silver	Žlutá Yellow
Pletivo Linen	Pneumatiky Tyres Black
Kůže Leather	Rězavá Rust
Hliníková Aluminium	Tmavá šedá Dark Grey
Chromová Chrome	Kované Gun metal

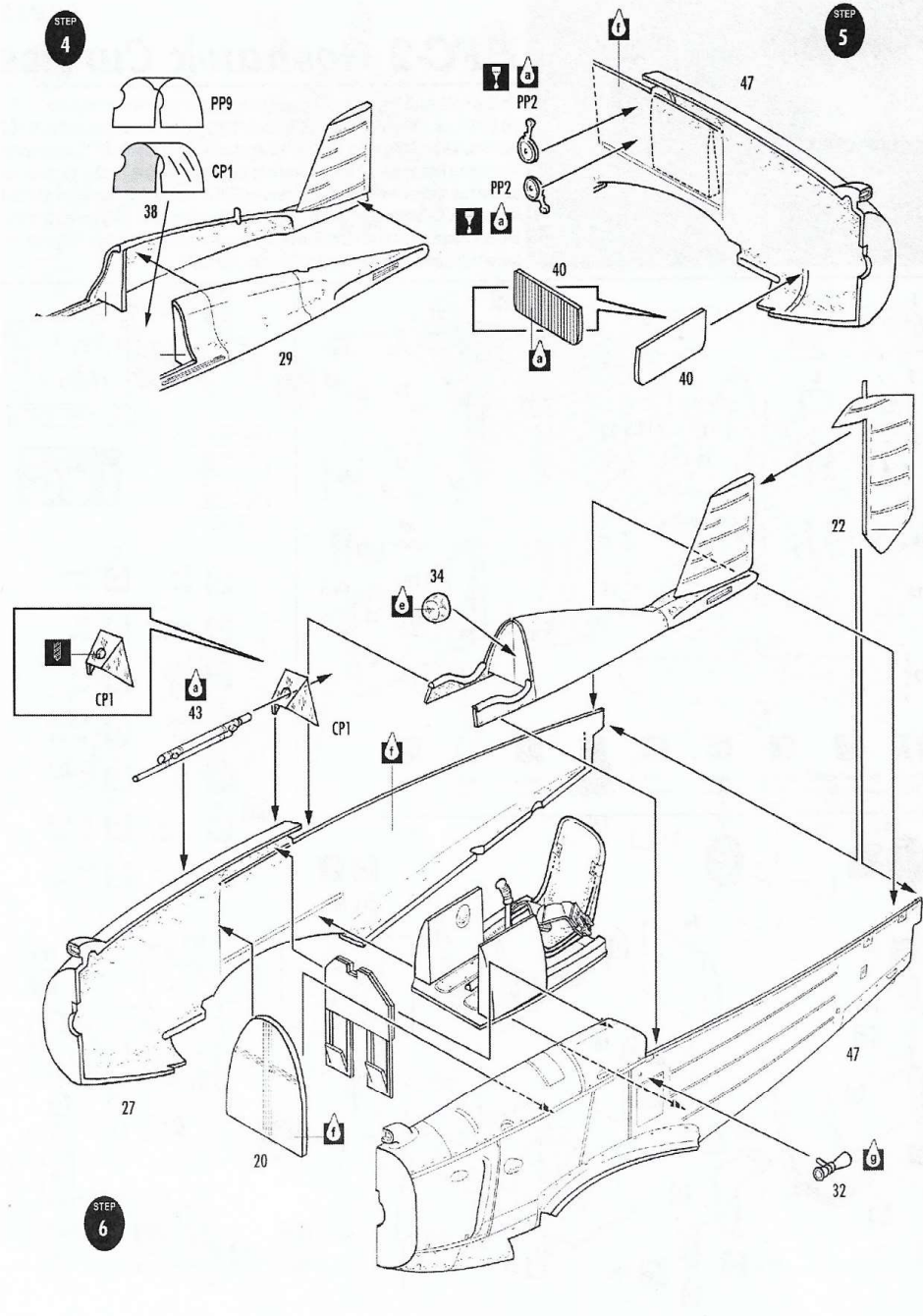
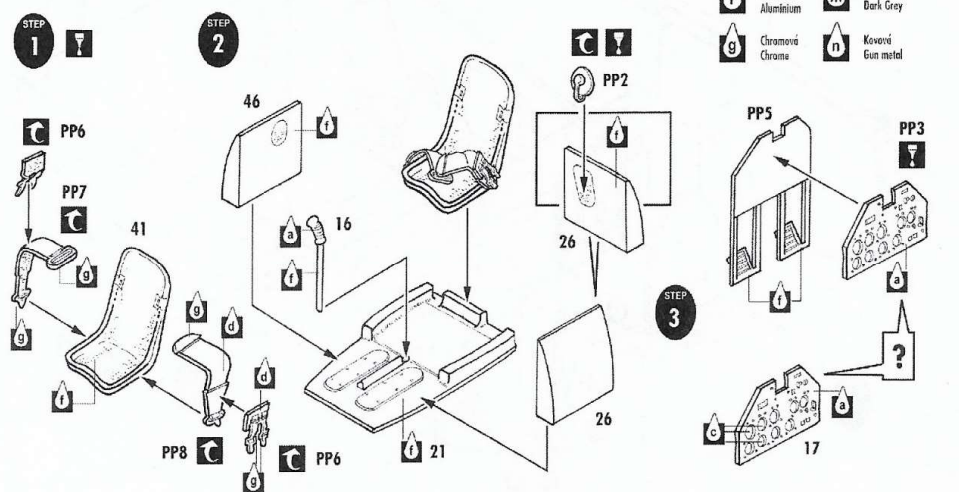

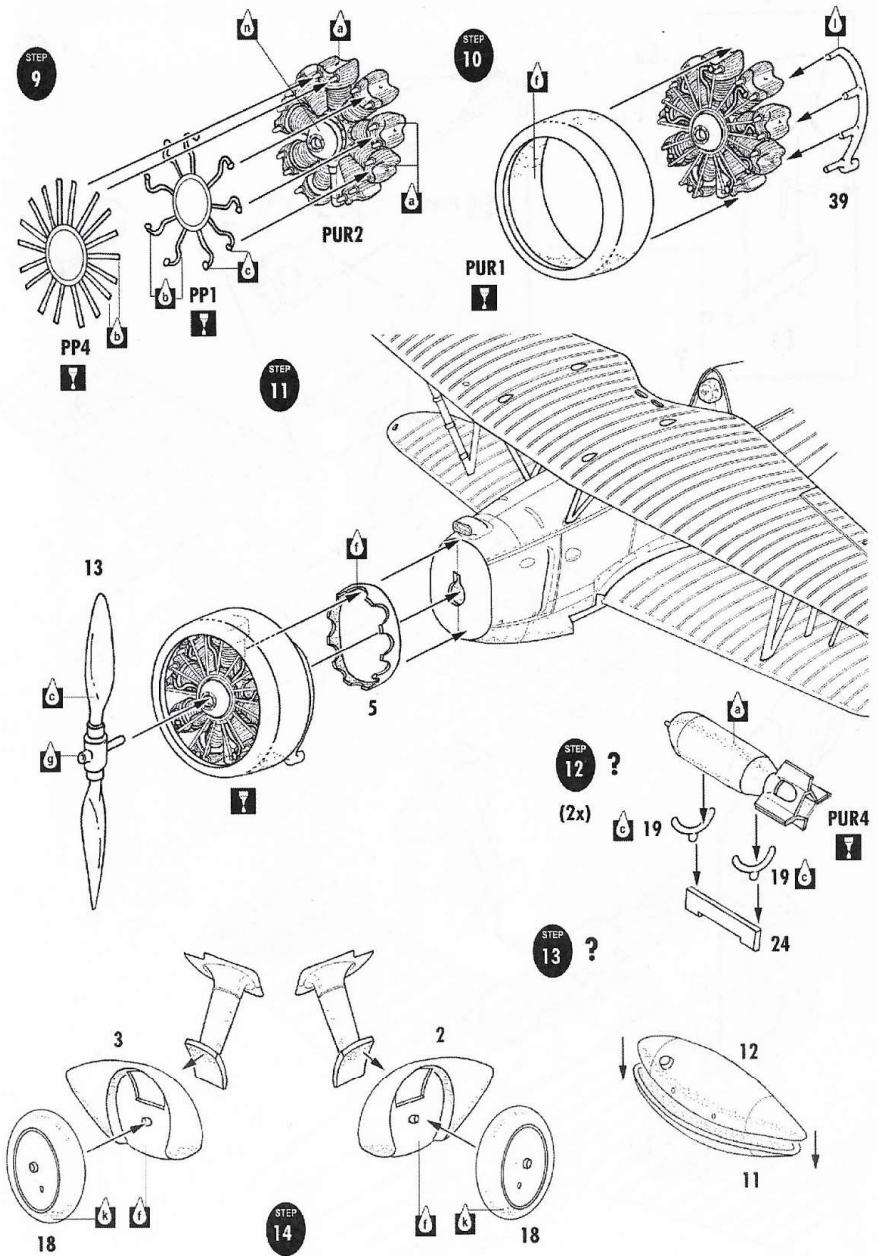
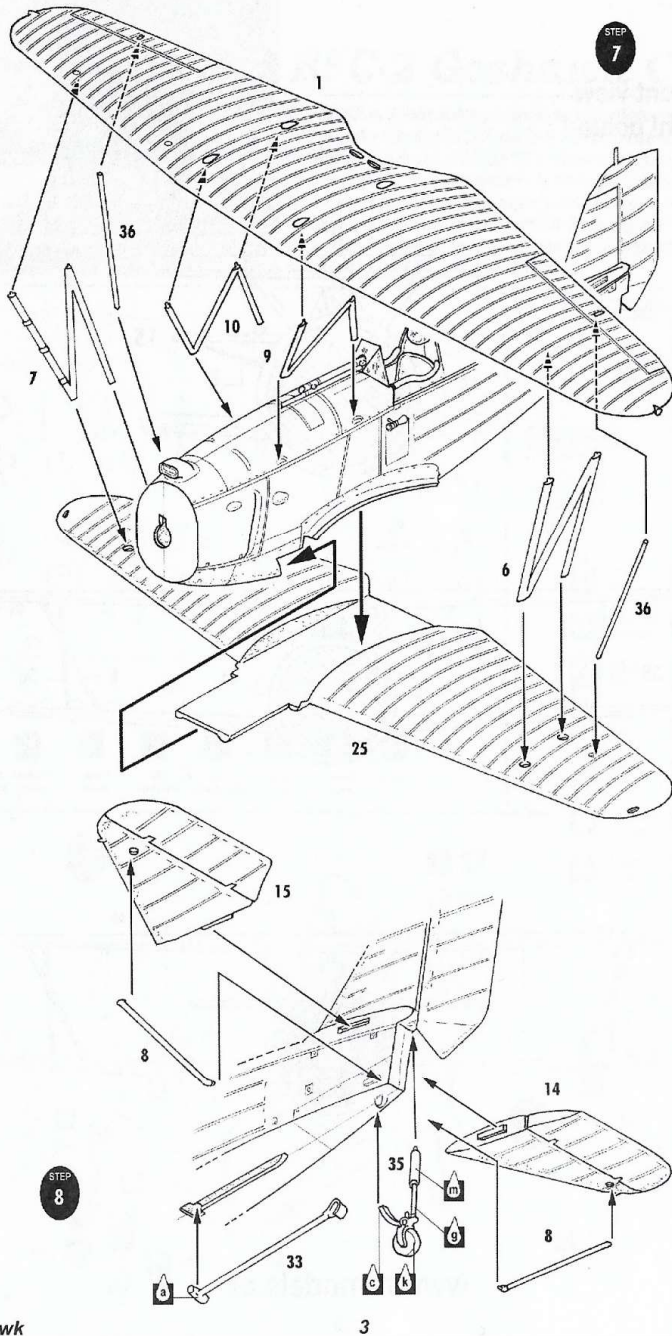

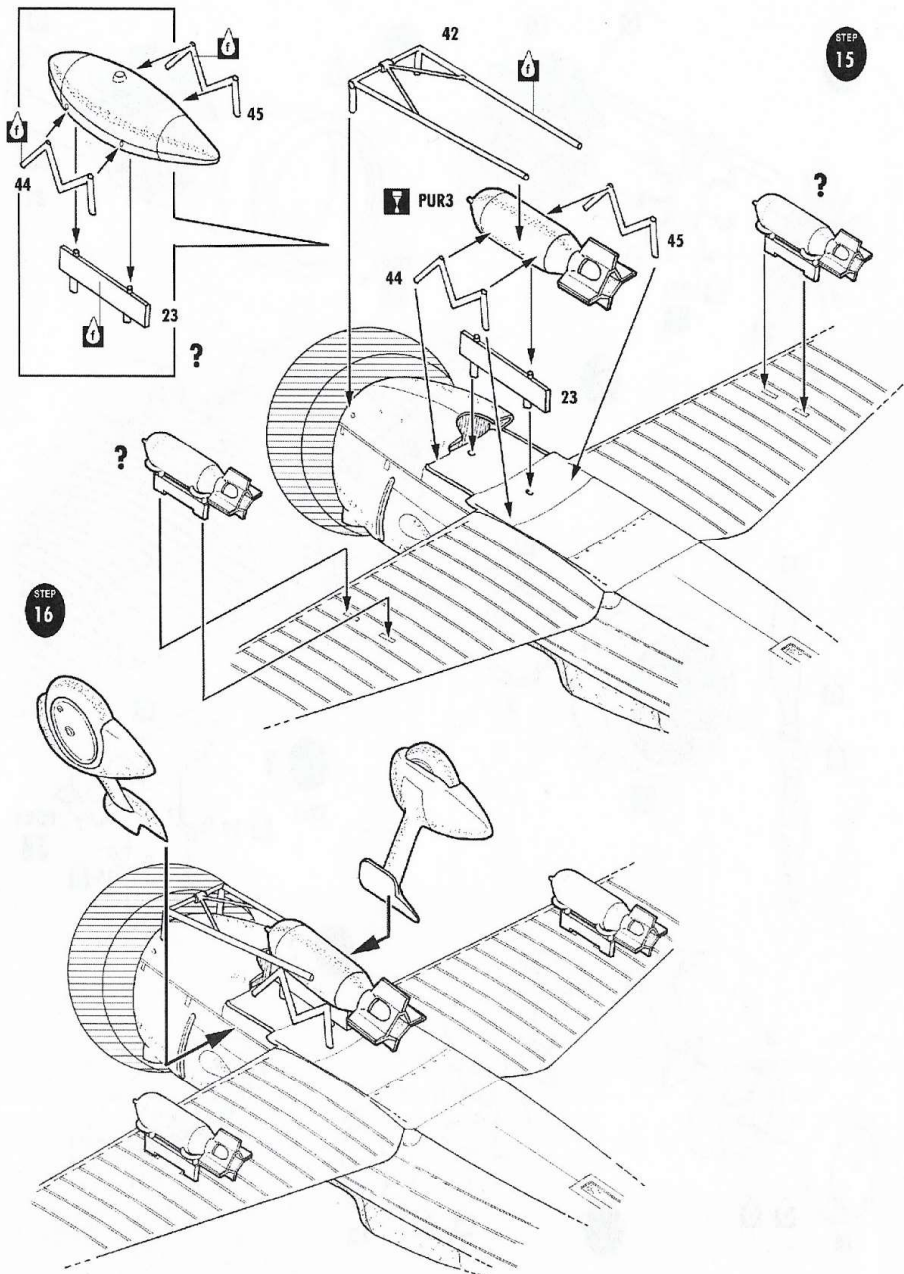

Front view
Čelní pohled

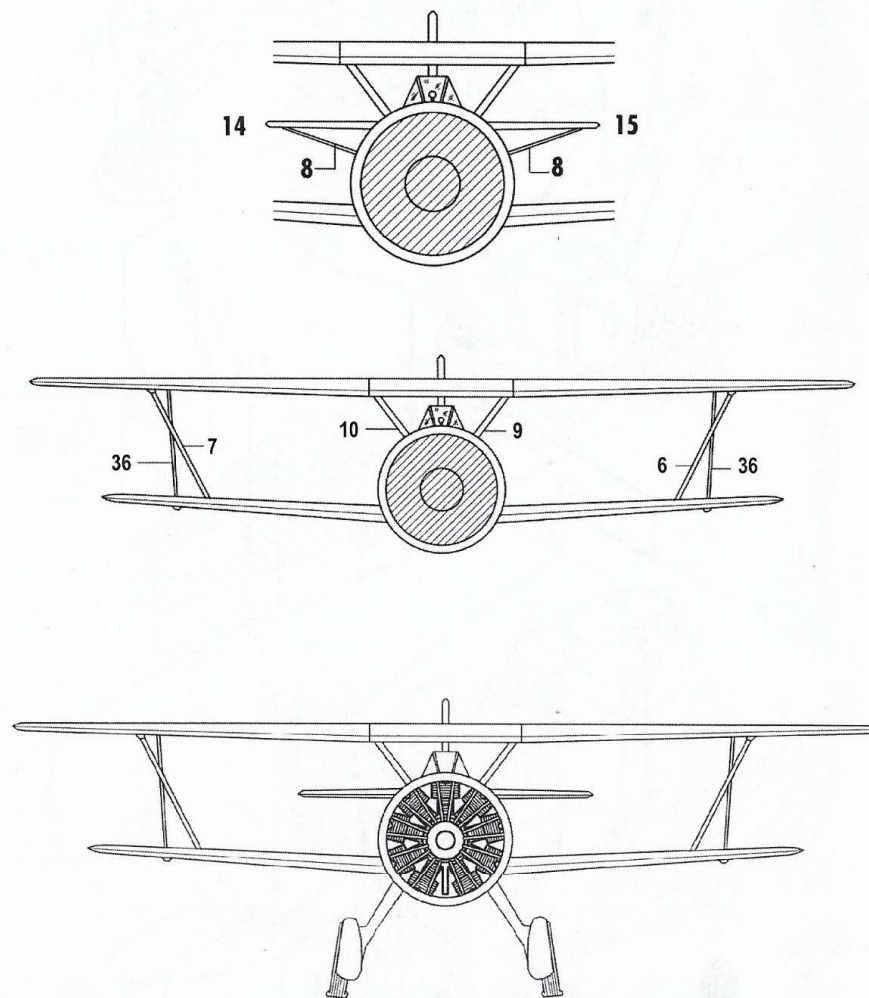

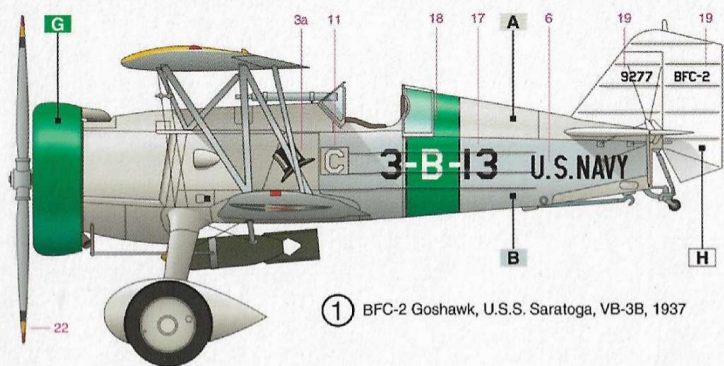

① BFC-2 Goshawk, U.S.S. Saratoga, VB-3B, 1937

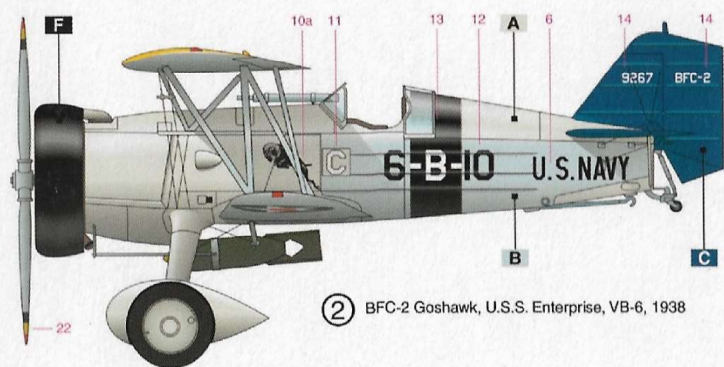

② BFC-2 Goshawk, U.S.S. Enterprise, VB-6, 1938

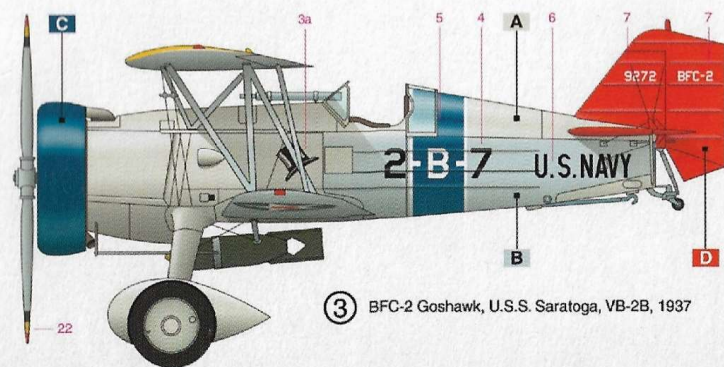

③ BFC-2 Goshawk, U.S.S. Saratoga, VB-2B, 1937

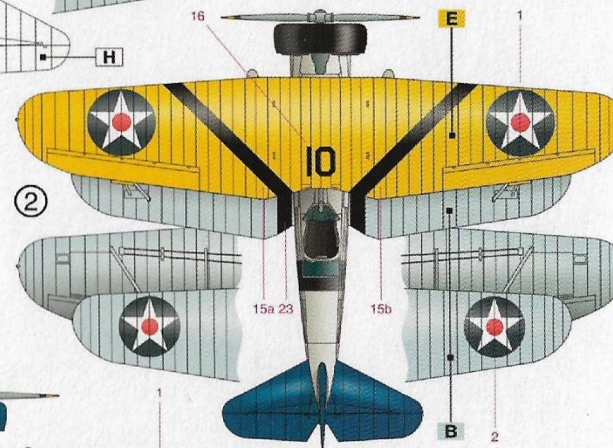
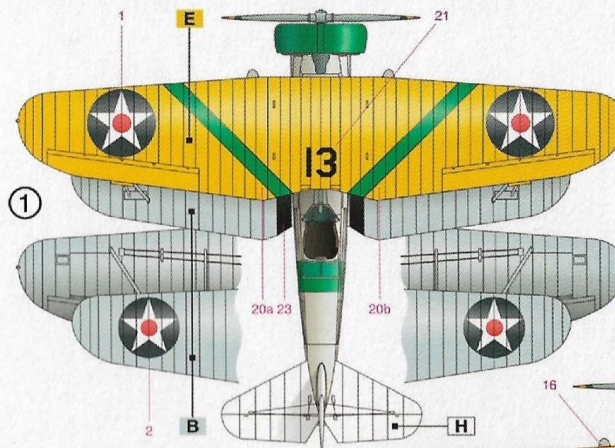

- A** Světle šedá
Light Grey
- B** Hliník
Aluminium
- C** Modrá
Blue
- D** Červená
Red
- E** Žlutá
Yellow
- F** Černá
Black
- G** Zelená
Green
- H** Bílá
White



U Iomu 7
795 01 Rýmařov
rsmodels@rsmodels.cz
www.rsmodels.cz
Czech Republic