

supermarine

# SPITFIRE VC TROPICAL

1/72 SCALE SERIES 2 2002

**PIONEER 2**

46 Haworth Road, Crossroads,  
Keighley, BD22 9DL, UK.

## SPITFIRE VC 'Tropical'

Probably the best known of all WWII aircraft, the Spitfire began its production life as the MkI. With the Hurricane it dominated the Battle of Britain, both aircraft outclassing their Luftwaffe counterparts.

However, as German technology improved its own aircraft, there was an urgent need to improve the Spitfire to cope with the new enemy aircraft.

From the MkI evolved the MkV, with further improvements to airframe and engine producing the VC (via a MkIII prototype never actually put into production)

Quantity production began in October 1941 using the Merlin 45 in place of the original Merlin III engine and the 'C' type 'Universal' wing. This wing permitted the use of a variety of armament configurations between cannon and machine guns.

The VC 'Tropical' was introduced because of the need to counter the strength of the Luftwaffe in several overseas theatres, not the least of these being the defense of Malta. A large air filter (Vokes Aero-Vee) was fitted giving the aircraft an ungainly appearance, together with an enlarged radiator and oil cooler intakes underneath the wings. None of these additions appreciably influenced the performance of the aircraft.

Our model ES187 from 154 SQN uses the standard 'C' wing but there were many VC 'D' or 'clipped' wing aircraft introduced, giving the aircraft a slightly poorer performance but an improved rate of roll for combat manoeuvres. The standard desert camouflage scheme was used (see next paragraph).

The VC 'Tropical' was used in many war theatres. Our model also depicts the USAF aircraft from the 308 Fighter Sqn. of the 31st Fighter Group US 12th AF in Tunisia. This aircraft sported the standard British Desert Camouflage scheme (Dark Earth and Middle Stone upper surfaces with Azure Blue undersurfaces) but with American insignia.

The RAAF also used many VCs, an interesting colour scheme being the overall natural metal finish with a completely white tail area and white leading wing edges.

The Spitfire MkV, with all its variants, eventually equipped more than 100 RAF units, was sold to nine overseas airforces and became the most commonly used fighter aircraft in WWII since it operated in every theatre where the RAF or the Allies were to be found.

Of course, the Spitfire itself was further improved throughout the war period and in its final variants continued in service long after hostilities had ceased. An actual VC (though not - tropical - ised) can be seen at the Shuttleworth Trust in Bedford - this aircraft being a 'C' with a 'D' wing.

## SPECIFICATION:

Wing Span	36' 10"	the 'D' wing reduced the span by 4'8"	area by 11 sq'
Length	30'		
Weight	5100 lbs (empty)		
	8600 lbs (loaded)		
Speed Max	357 m.p.h.		
Range	470 miles		
Ceiling	37000'		

Powerplant one Rolls Royce Merlin 45, developing 1470 hp.

Later and alternative versions.

Merlin 46, 50, 50A, 55, 56.

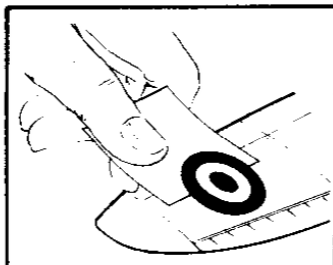
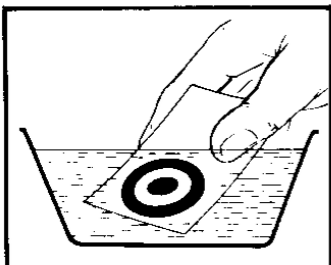

"Cut from decal sheet the section required. Place in warm water for 10-15 seconds. Slide from backing sheet directly on to model. Locate accurately and press down with soft cloth, removing excess water at same time."

PRINTED IN TURKEY

 GLUE  
 DO NOT USE HEATED GLUE  
 USE HEATED KNIFE  
 OPTIONAL CHOICE

1

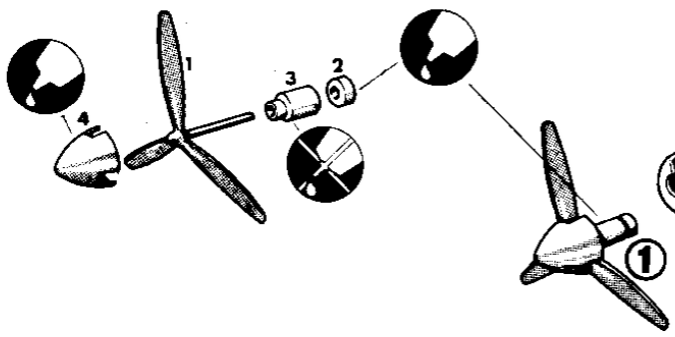

2

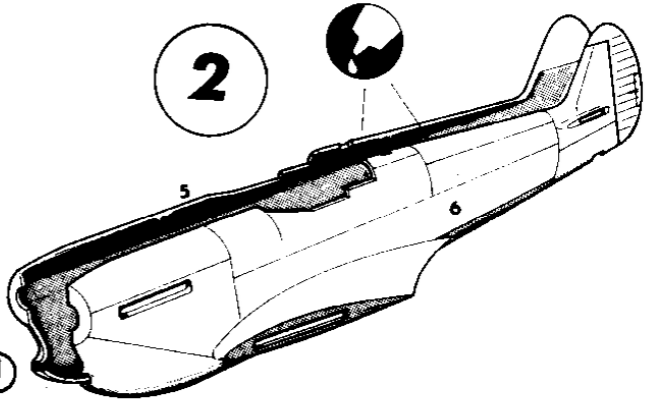

3

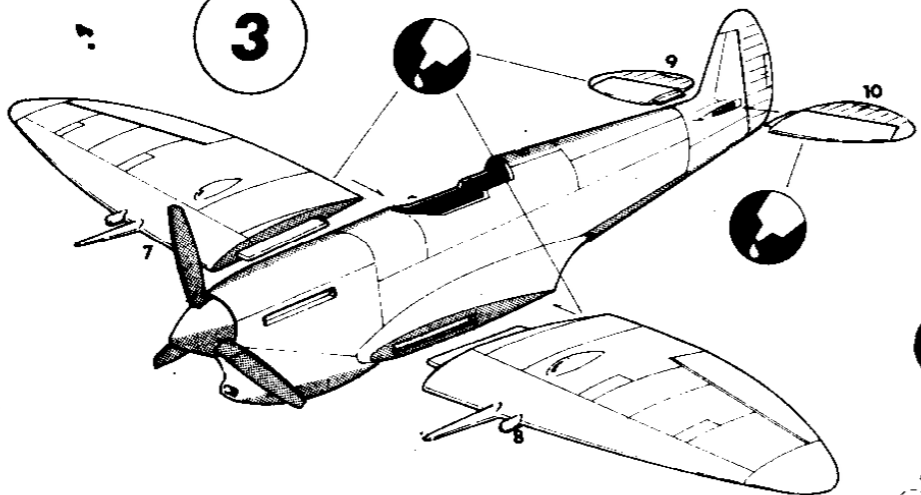

4

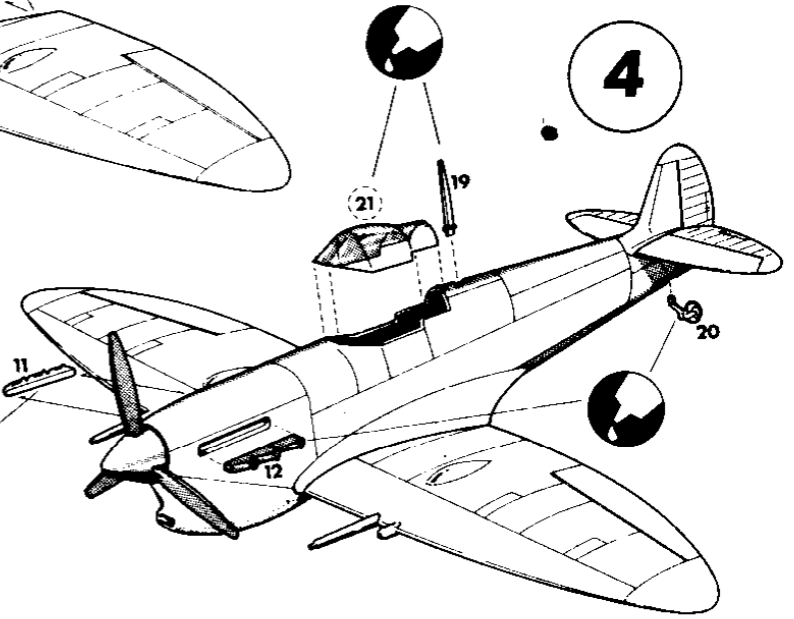

5

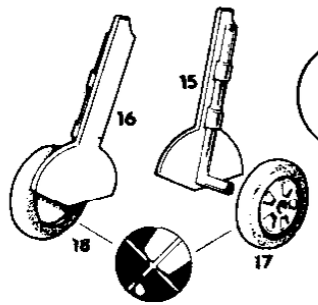

8

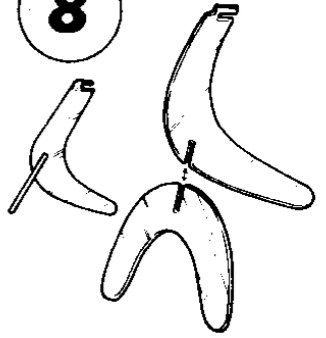

7

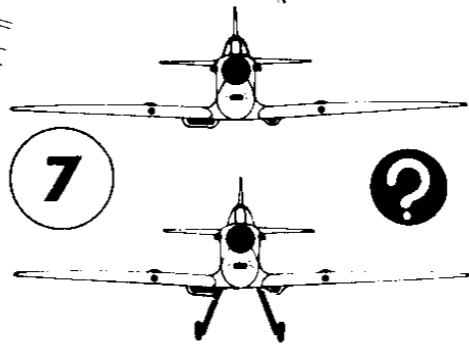

6

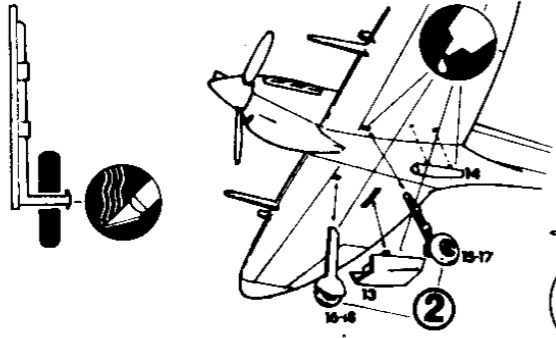

?



USAF 12 th. Air Force, 308 th. Fighter Squadron,  
31 st FG, Tunisia mid - 1943.

supermarine

# SPITFIRE

VC TROPICAL

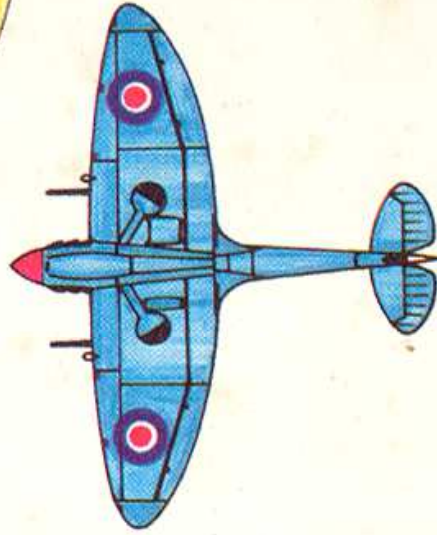
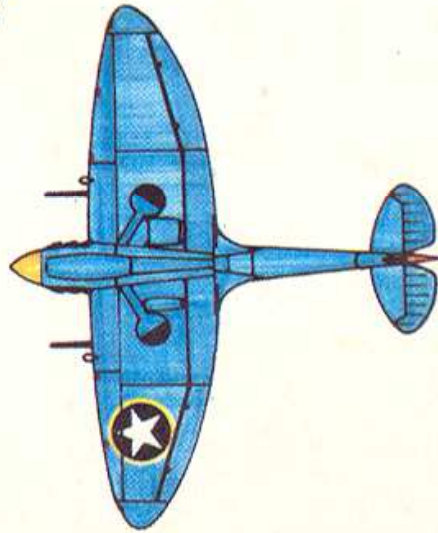
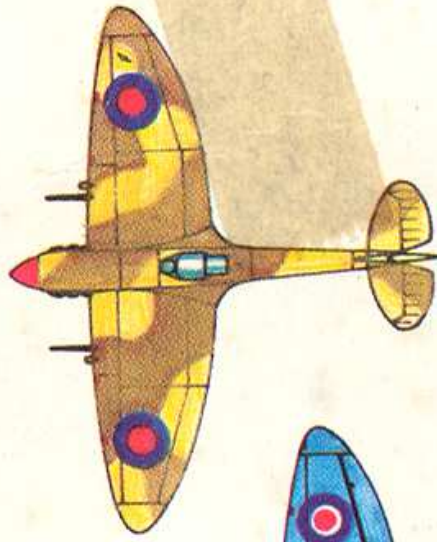
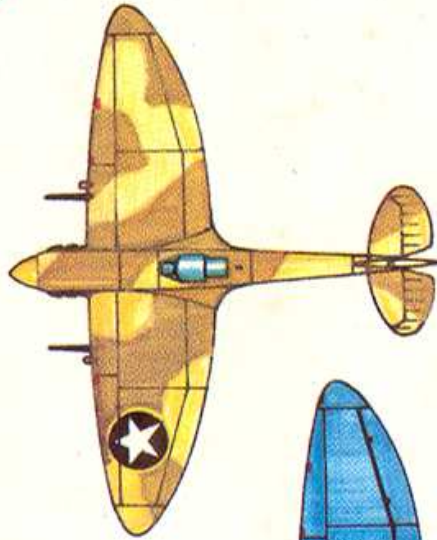
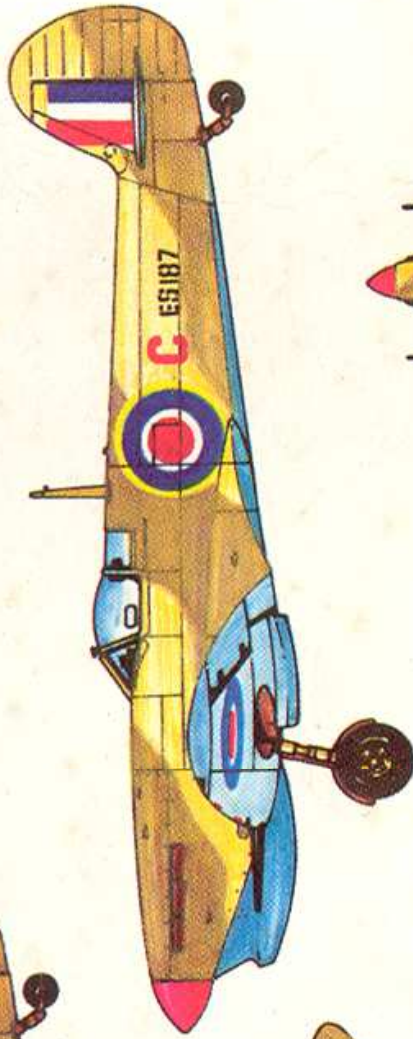
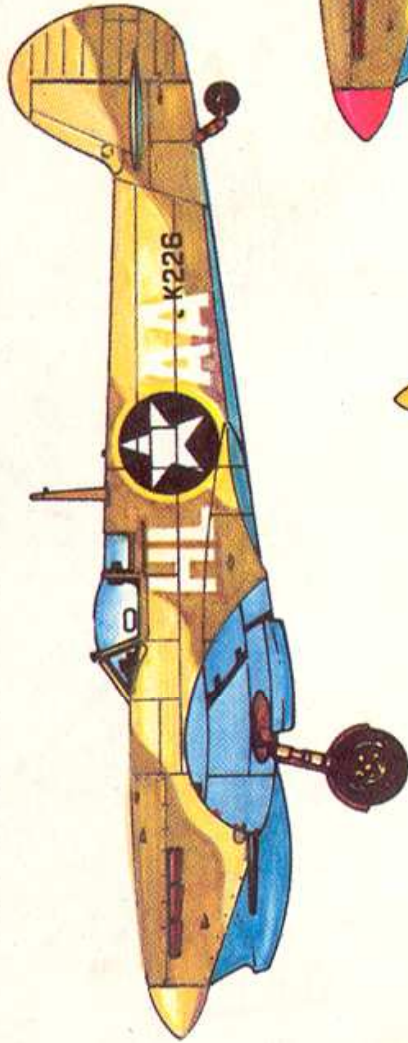

**RAF UPPER SURFACE**

- Dark Earth (HB2)
- Middle Stone (HB12)

**UNDER SURFACE**

- Azur Blue (HB13)

**SPINNER**

- Red (19)

USAF: as above but spinner Desert Sand (63)

RAF, Djidjelli, 154 Squadron December-1942



MADE IN TURKEY. ONLY DISASSEMBLED AND ASSEMBLED IN TURKEY.