

# Zbarvení & Označení Colours & Markings

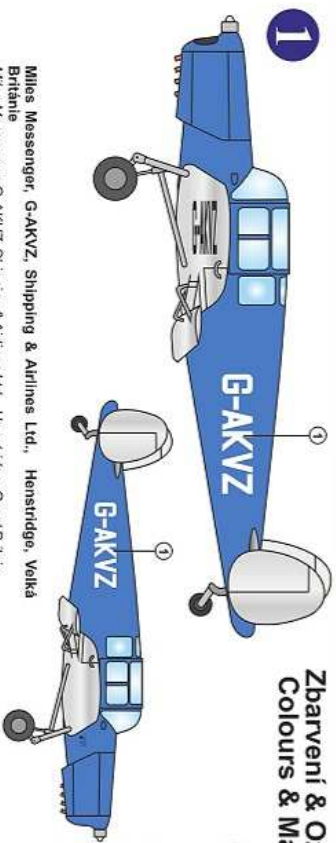

Miles Messenger, G-AKVZ, Shipping & Airlines Ltd., Henstridge, Velká Británie  
Miles Messenger, G-AKVZ, Shipping & Airlines Ltd., Henstridge, Great Britain

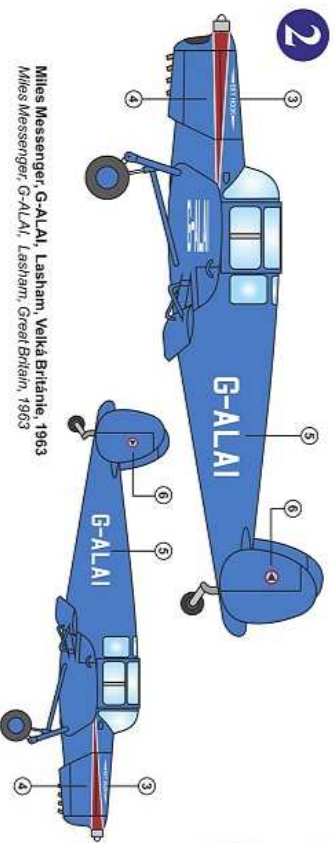

Miles Messenger, G-ALAI, Lasham, Velká Británie, 1963  
Miles Messenger, G-ALAI, Lasham, Great Britain, 1963

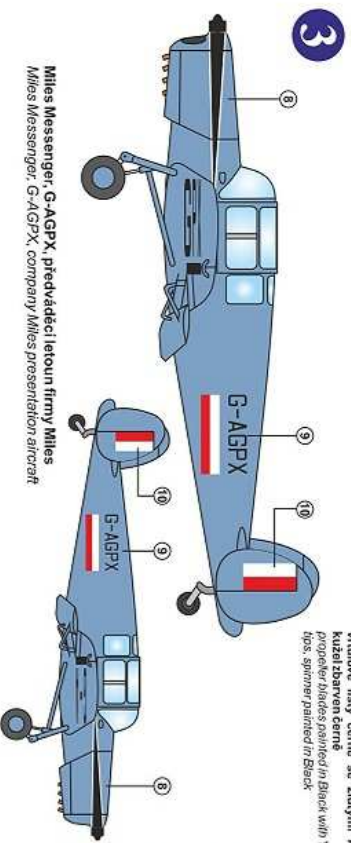

Miles Messenger, G-AGPX, předváděcí letoun firmy Miles  
Miles Messenger, G-AGPX, company Miles presentation aircraft

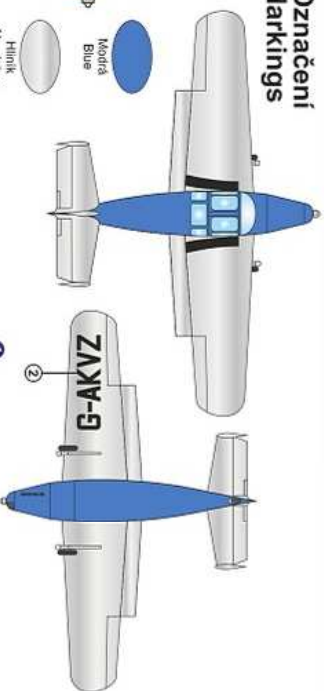

vrstevné listy světlé šedé s bílými výstřednými proužky, kužel zbarven hliníkovou barvou  
propeller blades painted in Light Grey with warning stripes in White, spinner painted in Aluminium

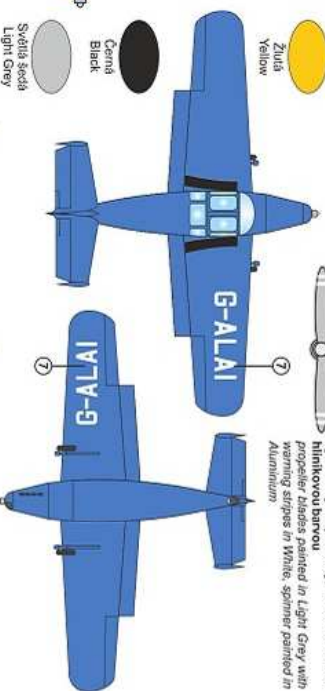

vrstevné listy světlé šedé s žlutými konci, kužel v barvě hliníku  
propeller blades painted in Light Grey with Yellow tips, spinner painted in Aluminium

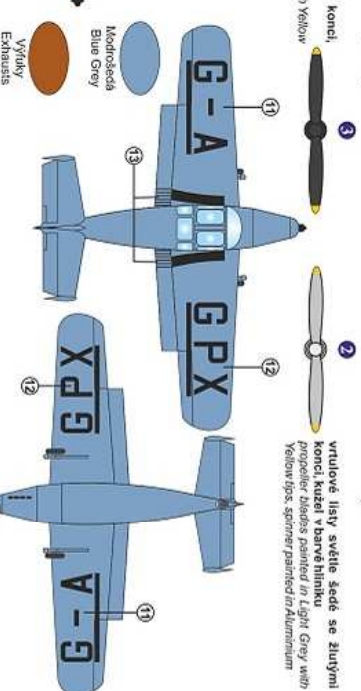

Modroseda  
Blue Grey

Výfuk  
Exhausts

vrstevné listy černé se žlutými konci, kužel zbarven černě  
propeller blades painted in Black with Yellow tips, spinner painted in Black

Stříbrná šedá  
Light Grey

Černá  
Black

Žlutá  
Yellow

Hliník  
Aluminium

3

2

1

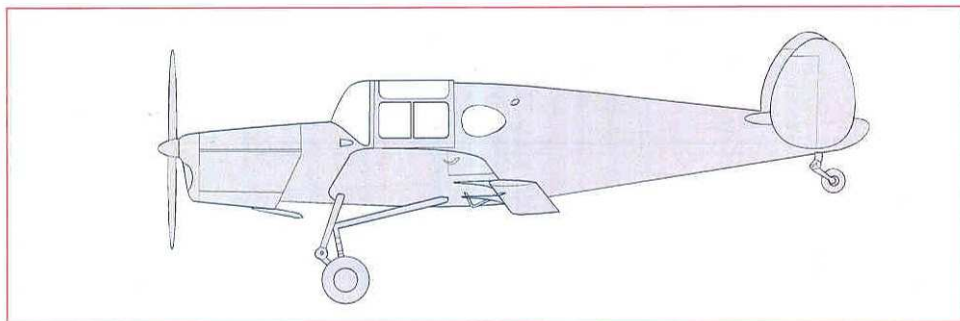

# Miles M.38 Messenger Mk I

## Historie

Miles M.38 Messenger je britské čtyřmístné spojovací a soukromé letadlo postavené společností Miles Aircraft . Messenger byl navržen tak, aby splňoval požadavky britské armády na robustní leteckou pozorovací stanici a spojovací letoun s nízkou rychlostí a nízkou údržbou. Mezi válečné uživatele tohoto typu patřili maršál Royal Air Force 1. baron Tedder a polní maršál Sir Bernard Montgomery. Během válečných let 21 vyrobených Messengerů přežilo válku sedmáct kusů a po vyřazení z povinností RAF byla většina přeměněna pro civilní použití jako Messenger 4A.

## History

The Miles M.38 Messenger is a British four-seat liaison and private owner aircraft built by Miles Aircraft. The Messenger was designed to meet a British Army requirement for a robust, slow speed, low maintenance air observation post and liaison aircraft. Wartime users of the type included Marshal of the Royal Air Force 1st Baron Tedder and Field Marshal Sir Bernard Montgomery . During the war years of the 21 Messengers produced seventeen Messenger 1s survived, and when retired from RAF duties most were converted for civilian use as the Messenger 4A.



**VOLITELNÉ**  
OPTIONAL



**VYVRTAT**  
DRILL HOLE



**TMEL**  
PUTTY



**ODSTRANIT**  
REMOVE

**Plastikové díly/Plastic parts**

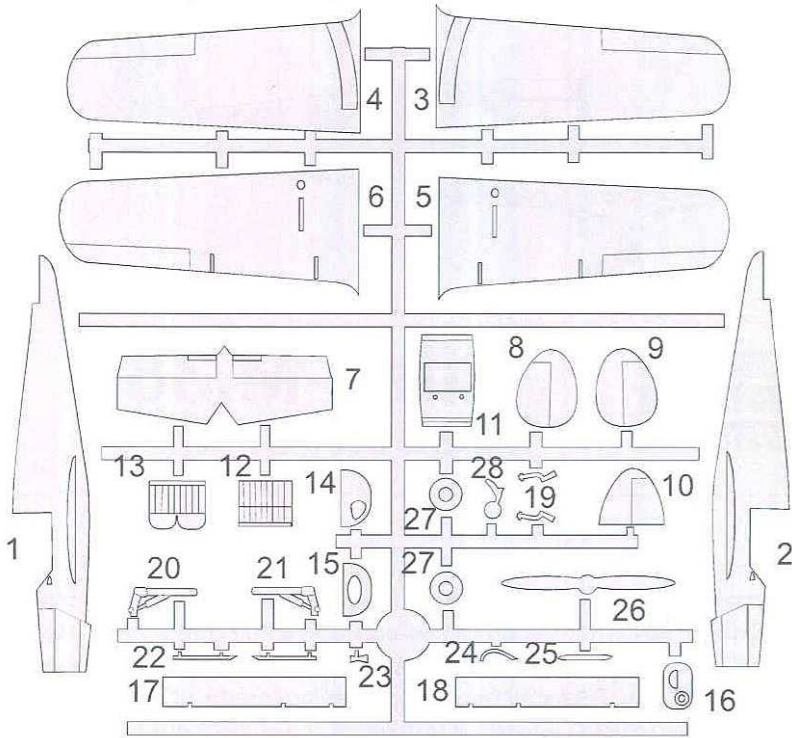

**Průhledné díly/  
Clear parts**



C1

**Stavební postup - Assembly instructions**

**1**

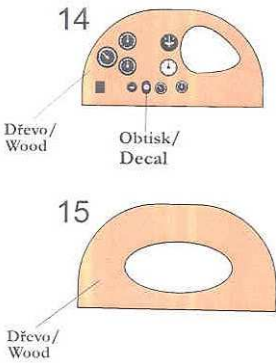

**2**

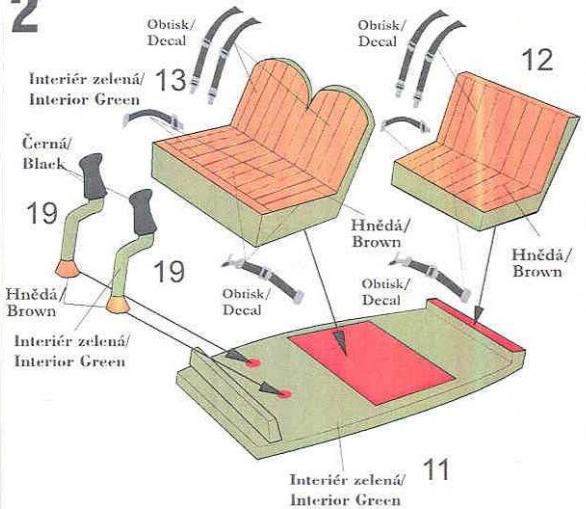

Assembly instructions

3

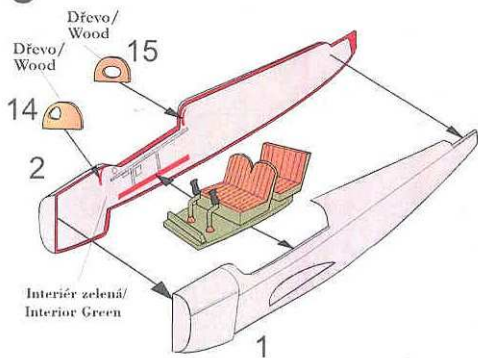

4

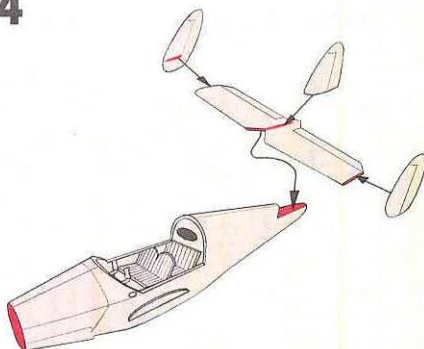

5

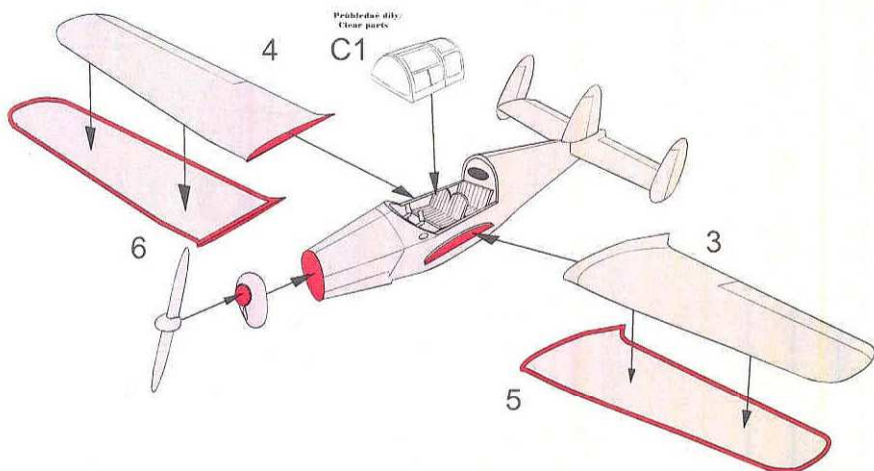

6

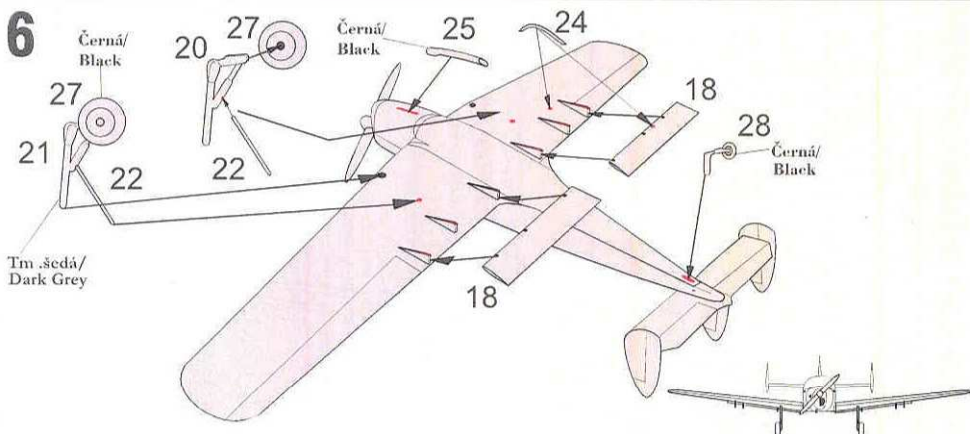

# Miles M.38 Messenger Mk I

