

Arado Ar 65

První prototyp letounu Ar 65 byl postaven v roce 1931. Byl poháněn motorem BMW VI o výkonu 500k. Prototyp byl dále uravován a výkony letounu se zlepšily. Seriové letouny byly zařazeny do tzv. *Reklamentfliegerabteilung*. Ve verzi Ar 65 E byla seriová výroba zavedena ve Warnemünde. Letouny byly vyzbrojeny dvěma kulomety 7,9 mm umístěnými nad motorem.

V březnu 1935 byla *Reklame-Staffel* přejmenována na *Jagdgeschwader 132* / později *JG 2*. Později byly letouny převedeny do *DVS Jagdfliegergruppe Schewerin*, později *I. St. G 162*. Poslední letouny verze Ar 65 F byly vyrobeny začátkem roku 1936. Na začátku války byly tyto letouny používány *Luftwaffe* k výcviku, mj. také na letištích Olomouc, Prostějov a Plzeň.

V roce 1942 - 43 byly Ar 65 používány u *Ergänzungs-Schleppgruppen 1 a 2* k vleku kluzáků *DFS 230* na východní frontě. Zde sloužily k zásobování, popř. transportu vojsk např. na Kubánském předmostí. V roce 1937 bylo několik letounů prodáno do Bulharska, kde se používali k výcviku pilotů.

The first prototype of the new fighter, the Ar 65 was powered with the BMW VI engine with a normal rating of 500hp. Flight trials with this and two additional prototypes dictated a number of modifications to the basic design, and the Ar 65 d that joined the programme in 1932. By comparison with the Ar 65 a, the handling and performance were markedly improved, and the RWM instructed Arado to prepare for series production for use by the so-called *Reklamefliegerabteilung*.

With further minor modifications, the fighter entered production at Warnemünde as the Ar 65 E, carrying an armament of the 7,9 MG 17 machine guns.

The *Reklame-Staffel*, which was to be officially designated *JG 132* / on March, 1935, began to receive the He 51, operating this type alongside the Ar 65 until, in 1935 the latter was the Ar 65 transferred to the *DVS Jagdfliegerschule* at Schlessheim to serve in the fighter training role.

Early of the war were Ar used by *Luftwaffe* to train role also by *schule* at Olmutz, Prostnitz, Pilsen.

In year 1942-43 were Ar 65 used by *Ergänzungs-Schleppgruppe 1 and 2* to tow gliders *DFS 230* carrying troops from the Kuban bridge head in Russia.

In year 1937 were some machines sold to Bulgaria, were used to the training role.

Technická data / Specifications

Rozpětí / Span :	11,20 m
Délka / Length :	8,40m
Vzletová hmotnost / Full weight :	1915kg
Max. rychlost / Max. speed .	300 km/h
Dostup :	7600 m

Prameny / References :

W. Green The Warplanes of the Third Reich
 Flugzeug foto Archiv
 Avions

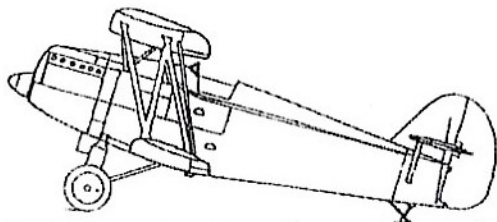

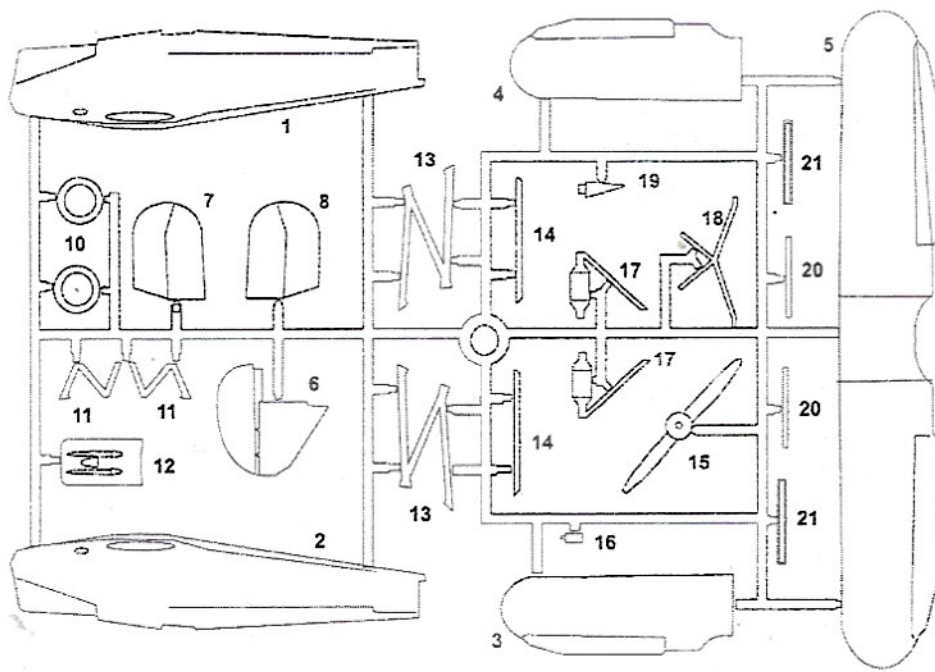

Resin parts



Re 1

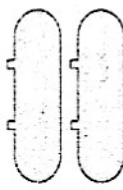

Re 2

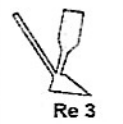

Re 3

Photo-Etched parts



	Barvy Colour	H-Humbrol Ag- Agama
A	Black	H-33 Ag 07M
B	White	H-34 Ag 01M
C	RLM 02	H-162 Ag N6N
D	Brown Yellow	H-94 Ag N24M
E	Gun Metal	H-27004 Ag 32Me
F	Siver	H-27003 Ag 08Me

Transp part



Tr1



Tr2

INSTRUCTIONS

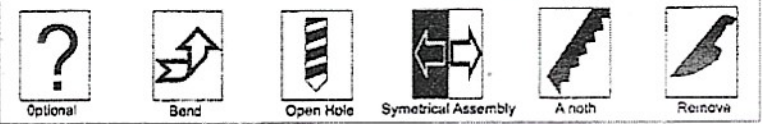
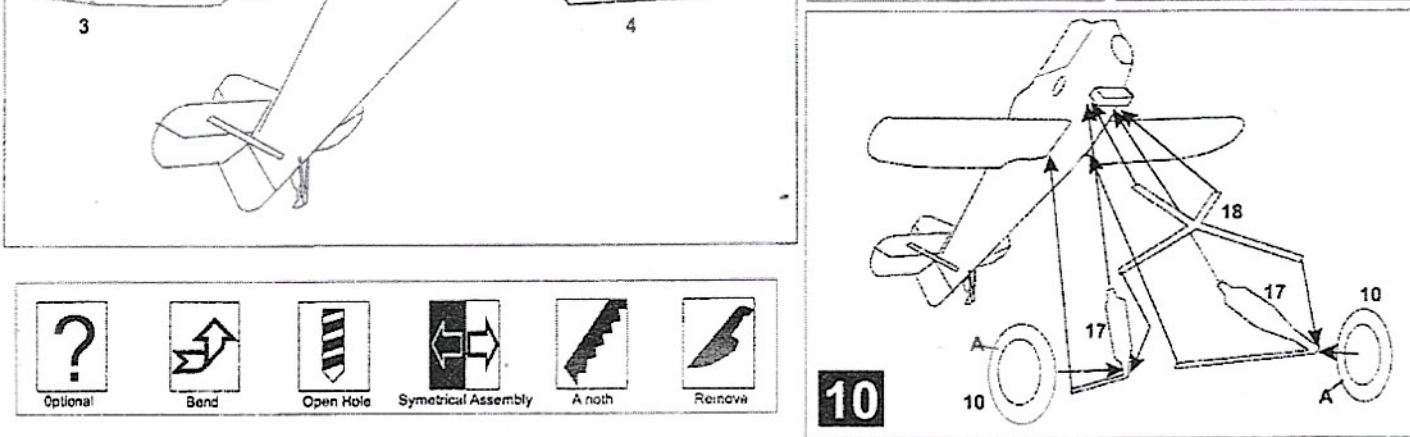
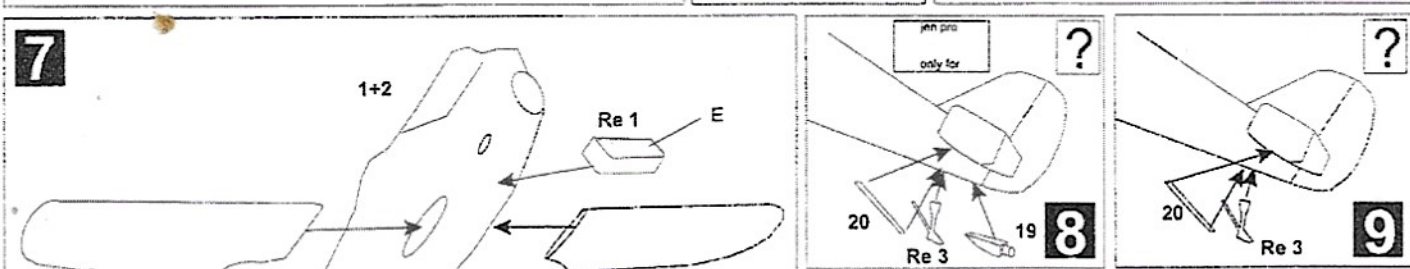
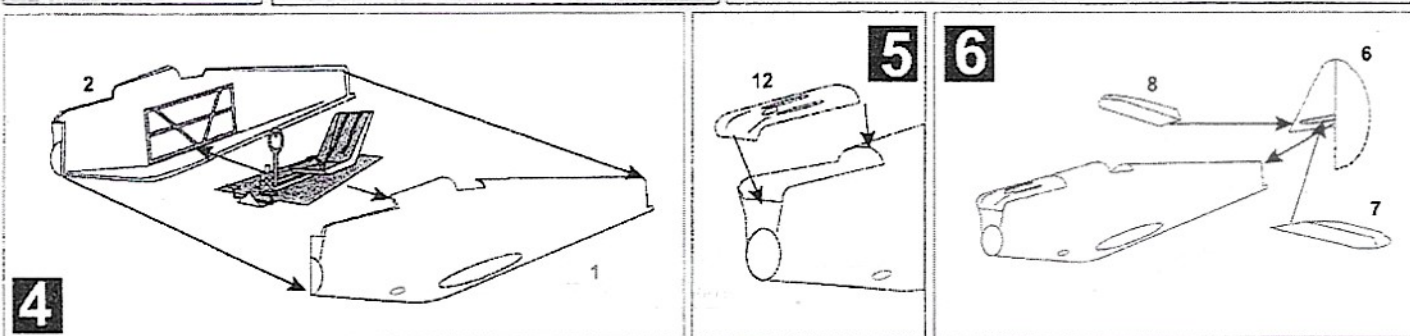
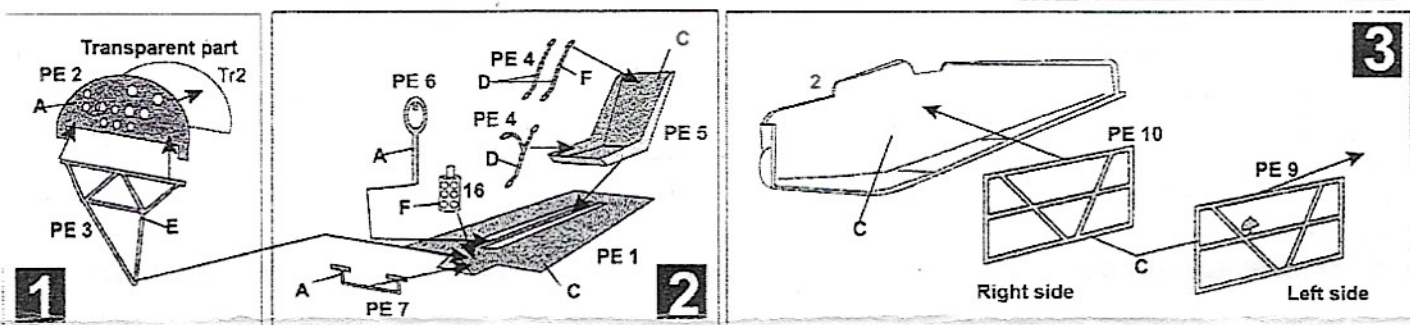

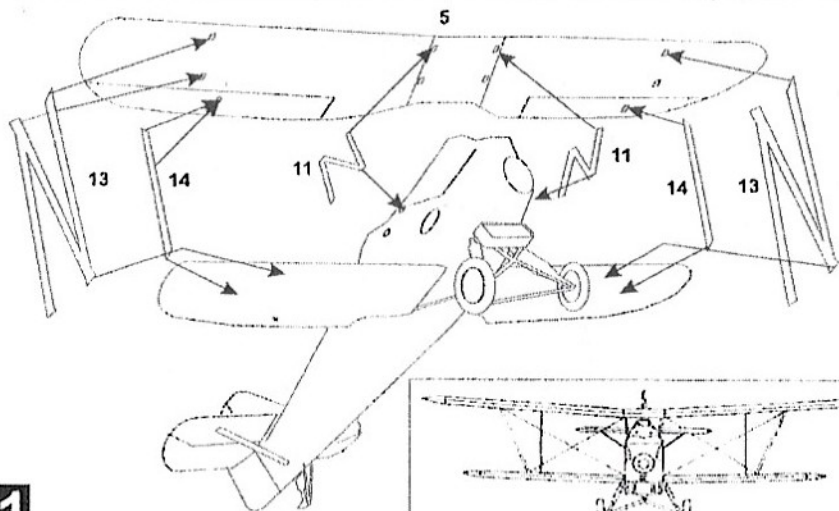

11



12

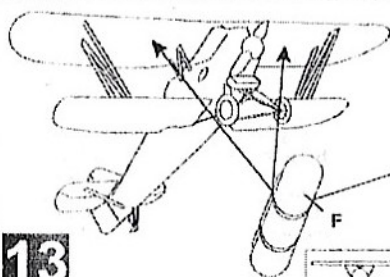

13

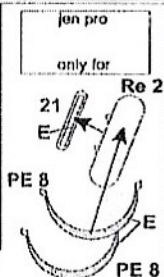

14

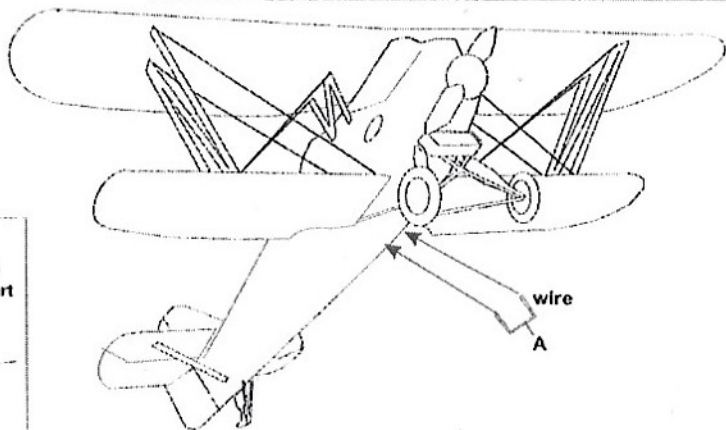

15

Tr 1
Transparent part



① Arado Ar 65, Luftwaffe, Erg. Gr (S)1, LLG 1 East front 1942-43

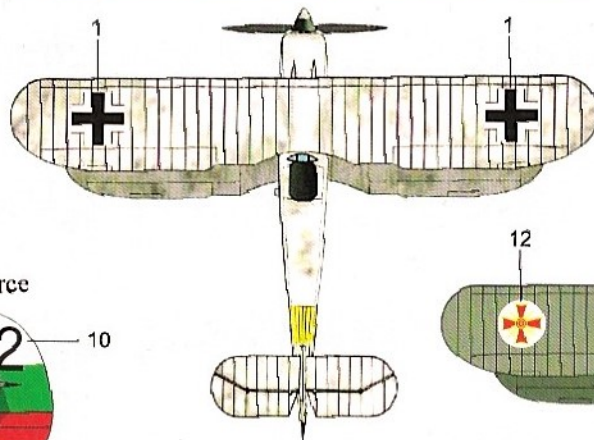
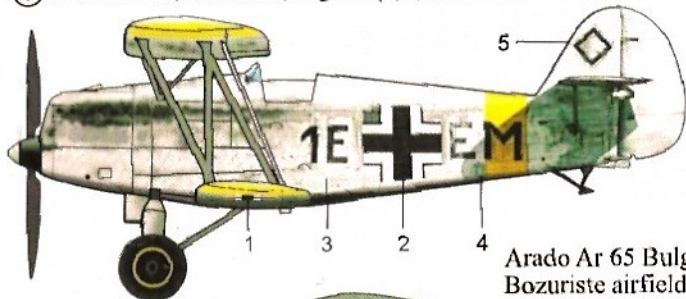

Arado Ar 65 Bulgarian Airforce
Bozuriste airfield 1938

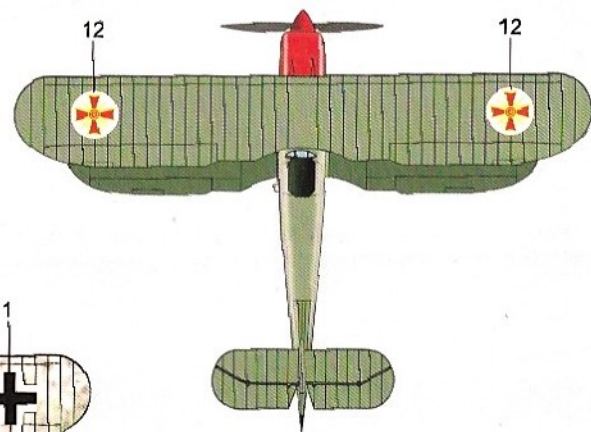
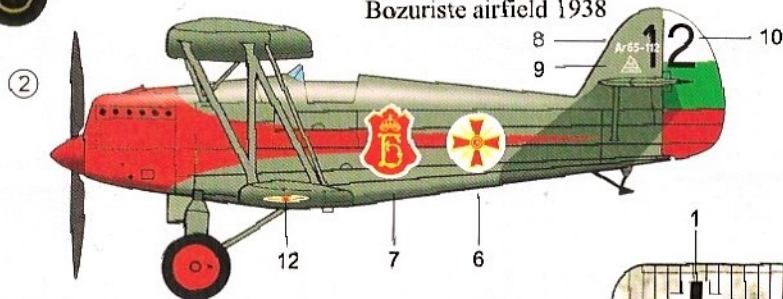

③ Arado Ar 65, Luftwaffe, Erg. Gr (S)1, LLG 1 East front 1942-43

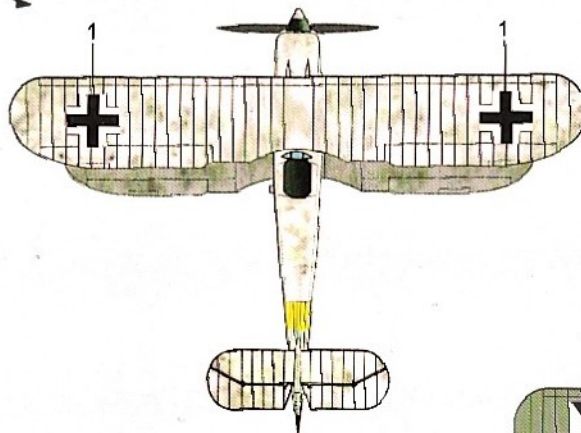
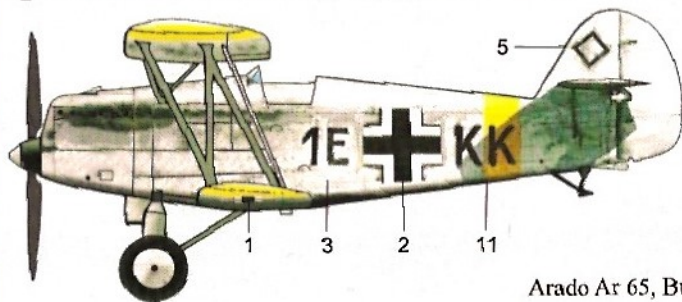

Arado Ar 65, Bulgarian Airforce, 1940

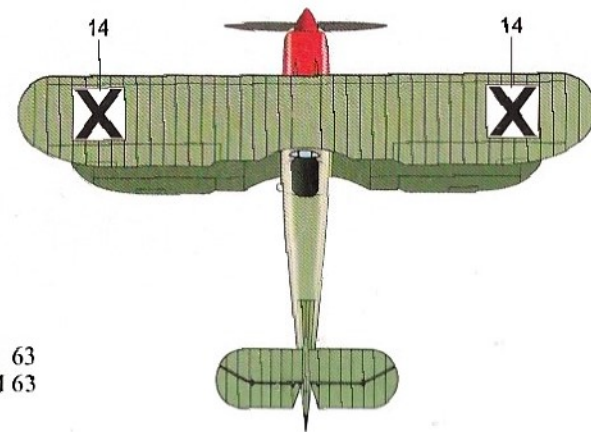
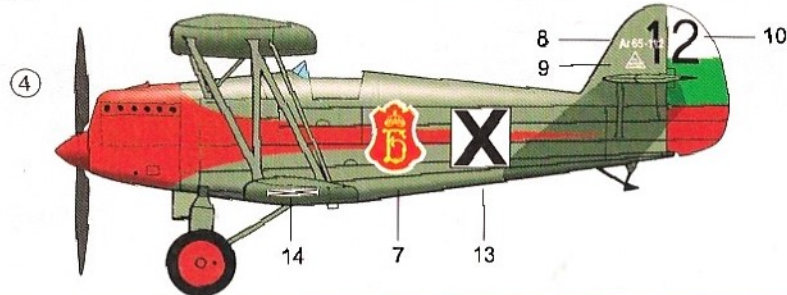

-  RLM 63
-  Červená - Red
-  Zelená - Green
-  Bílá přes RLM 63
White over RLM 63
-  Žlutá - Yellow

Arado 65

Německý stíhací letoun / German fighter from WW II

4 obtiskové verze
4 decal version



The Ar 65 was a prewar German biplane. Further minor modifications were carried out and the biplane fighter entered production at Warnemünde as the Ar 65e, which was armed with two 7.9 mm MG17 machine guns mounted on the nose ahead of the cockpit. In 1935 the Arado Ar 65 transferred to the DVS *Jagdfliegerschule* at Schliessheim to serve in the fighter-training role. From early in the war the Ar 65 were used by the Luftwaffe in training role at Olmutz, Prosnitz and Pilsen. During the period from 1942-43 they were used to tow DFS 230 gliders for carrying troops from Kuban bridgehead in Russia.



1:72 SCALE
PLASTIC KIT

92109

