

LIMITED EDITION!

CED48235

# Spitfires

## Eagles and Aces Part 1



**Spitfire Mk Vb**  
Sqn. Leader Eric Thomas  
No 133 Sqn, Biggin Hill  
American Eagle Squadron



**Spitfire Mk Vb**  
Robert Stanford Tuck-29 kills  
Commander, Biggin Hill Wing



**Spitfire Mk Vb**  
Sqn. Leader Eric Thomas  
No 133 Sqn, Biggin Hill  
American Eagle Squadron



**Spitfire Mk Vb**  
Sgt. A. C. Younge  
No 91 Sqn's 'B' Flight, Hawkinge  
American Eagle Squadron

Recommended kit:  
Tamiya Spitfire Mk.V

**Cutting  
Edge**

MODELWORKS [www.meteorprod.com](http://www.meteorprod.com)

®  
P.O. Box 3956  
Merrifield, VA 22116  
USA



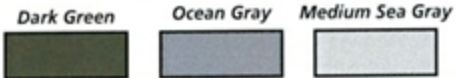

Under cockpit on right side

*The Lord Mayor (York)*

## Spitfire Mk Vb

Sqn. Leader Eric Thomas  
No 133 Sqn, Biggin Hill  
June 1942

**American Eagle Squadron**

18" wide



Camo had a soft edge



Main wheel hub MD\*A

## Spitfire Mk Vb

Robert Stanford-Tuck-29 kills  
Commander, Biggin Hill Wing  
January 1942

Right side

Roundel in same position on right side

Right side

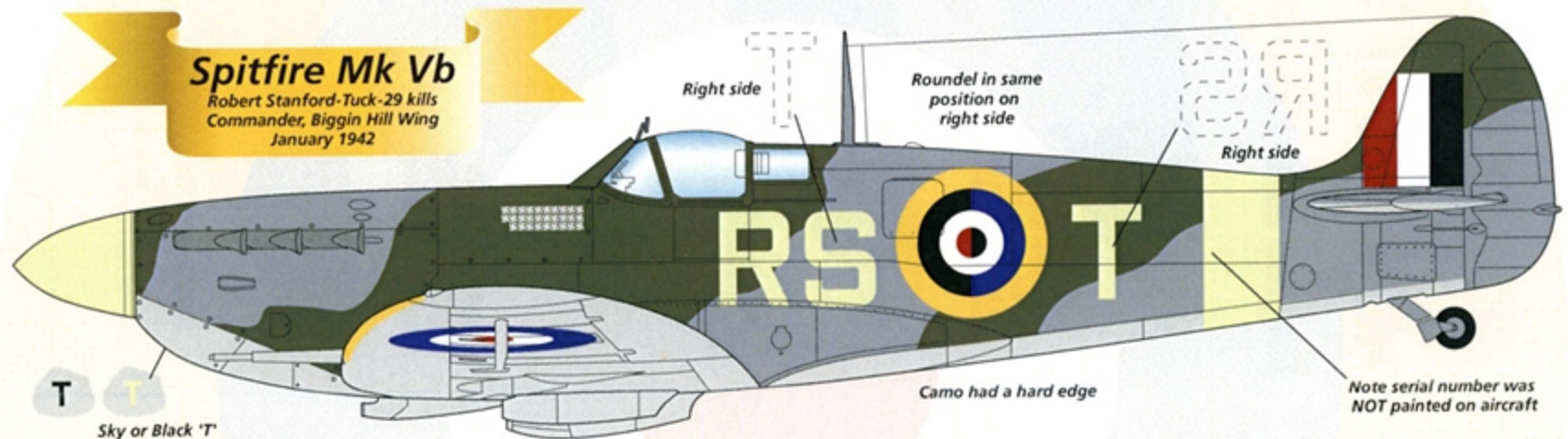

Camo had a hard edge

Note serial number was NOT painted on aircraft

T T  
Sky or Black 'T'  
Note this "T" was probably NOT applied.  
Provided only in case a new photo is found.

## Spitfire Mk Vb

Sqn. Leader Eric Thomas  
No 133 Sqn, Biggin Hill  
May, 1942

**American Eagle Squadron**

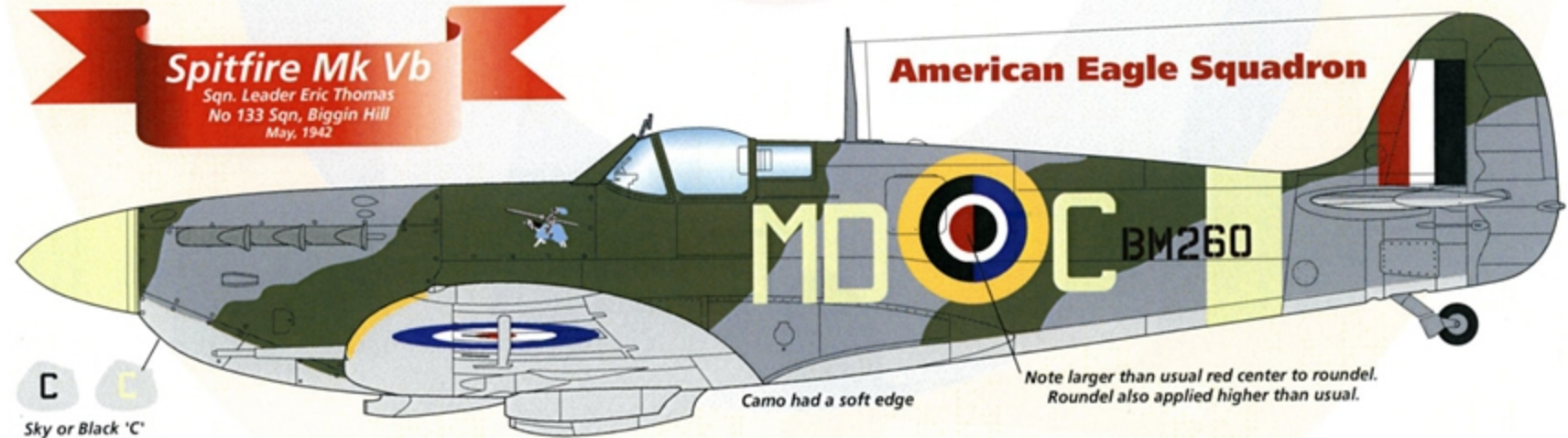

Camo had a soft edge

Note larger than usual red center to roundel.  
Roundel also applied higher than usual.

C C  
Sky or Black 'C'  
(black is most likely)

## Spitfire Mk Vb

Sgt. A. C. Younge  
No 91 Sqn's 'B' Flight, Hawkinge  
Summer 1942

Note non-standard camouflage demarcation

**American Eagle Squadron**

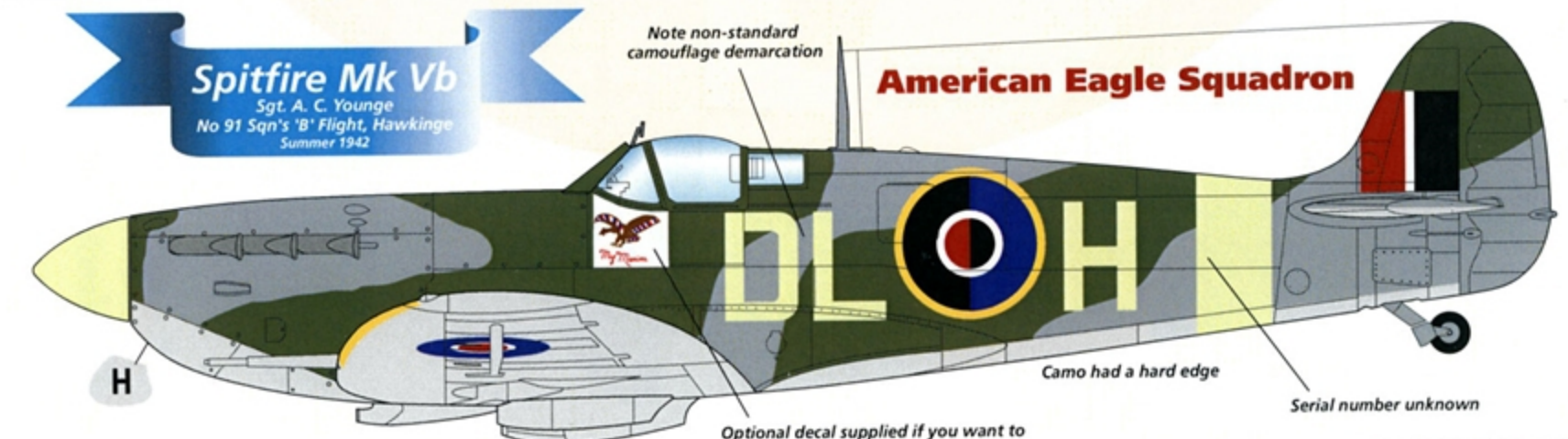

Camo had a hard edge

Serial number unknown

Optional decal supplied if you want to paint white background yourself



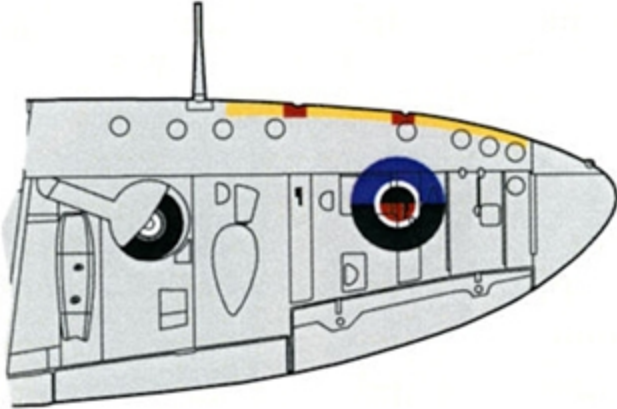
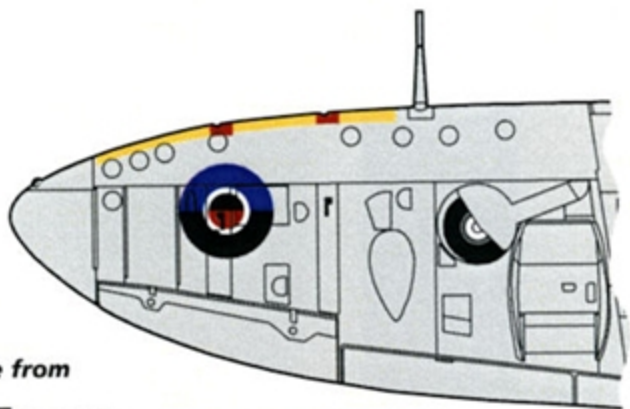
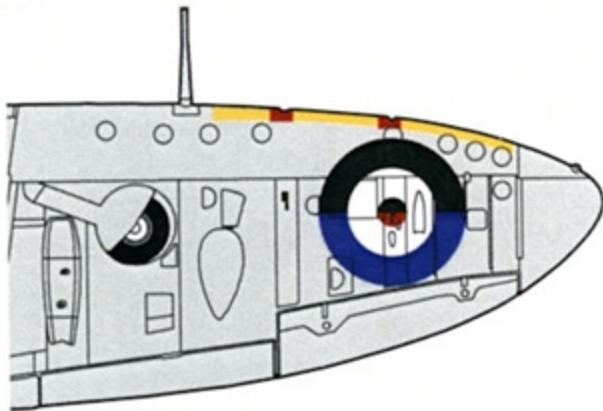
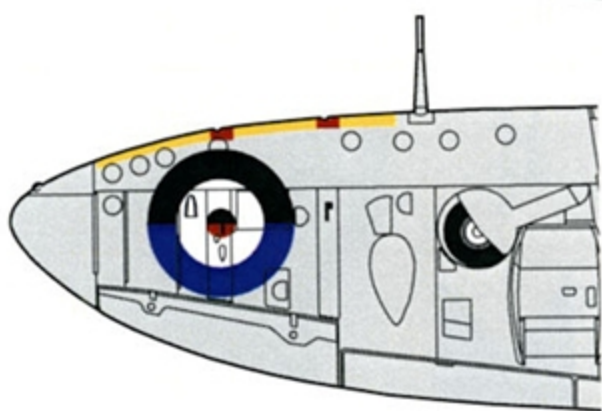
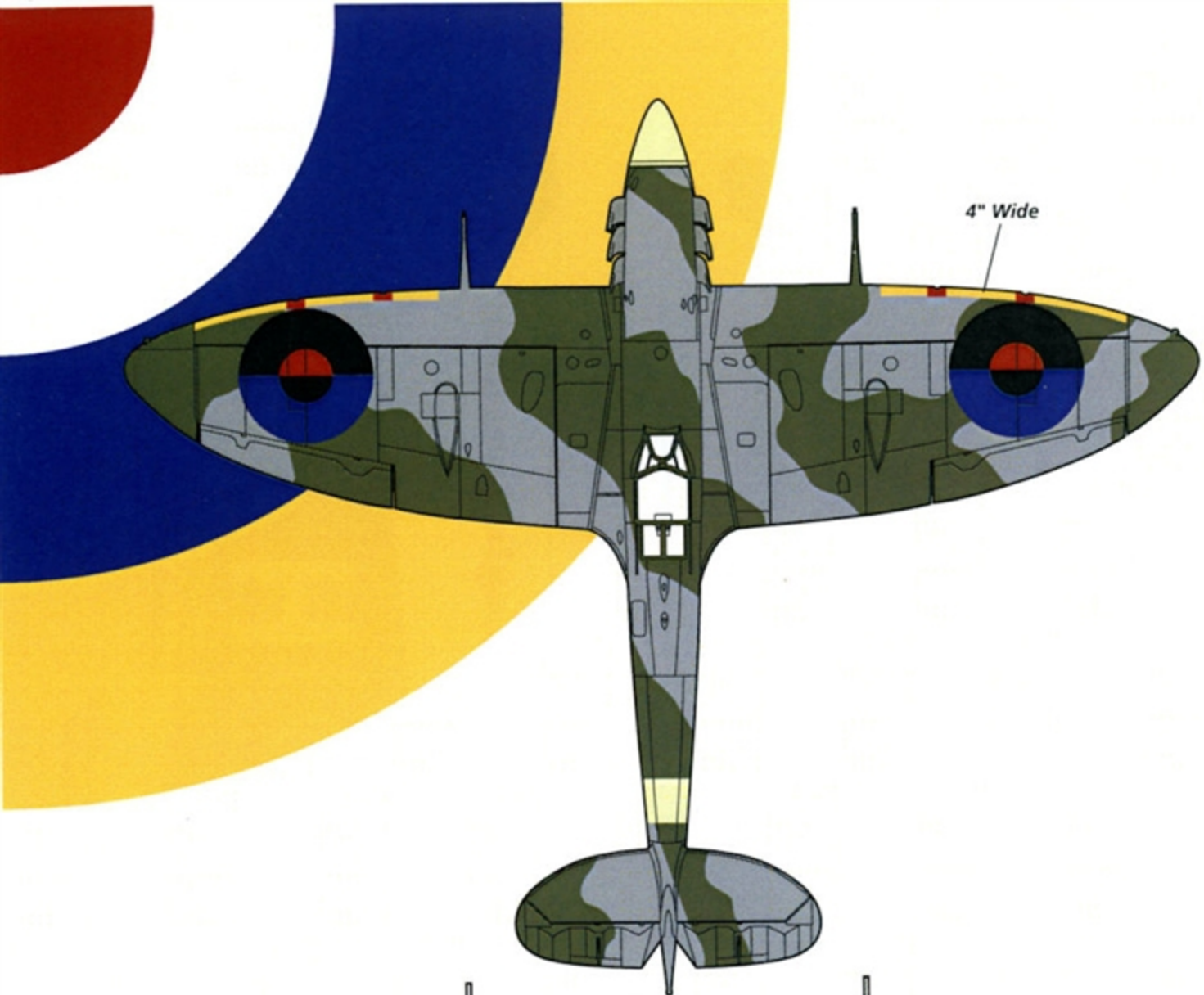

...available from

**Meteor**  
  
**Productions**  
Inc.

P.O. Box 3956, Merrifield, VA 22116 USA

☎ 703/440-8720 FAX 703/440-8724

[www.meteorprod.com](http://www.meteorprod.com)

*Write, call, or visit our home page to order our 120+ page catalog of decals, kits, conversions, tools, books, magazines, etc., and we'll send it to you right away!*

© Cutting Edge Modelworks, 2004

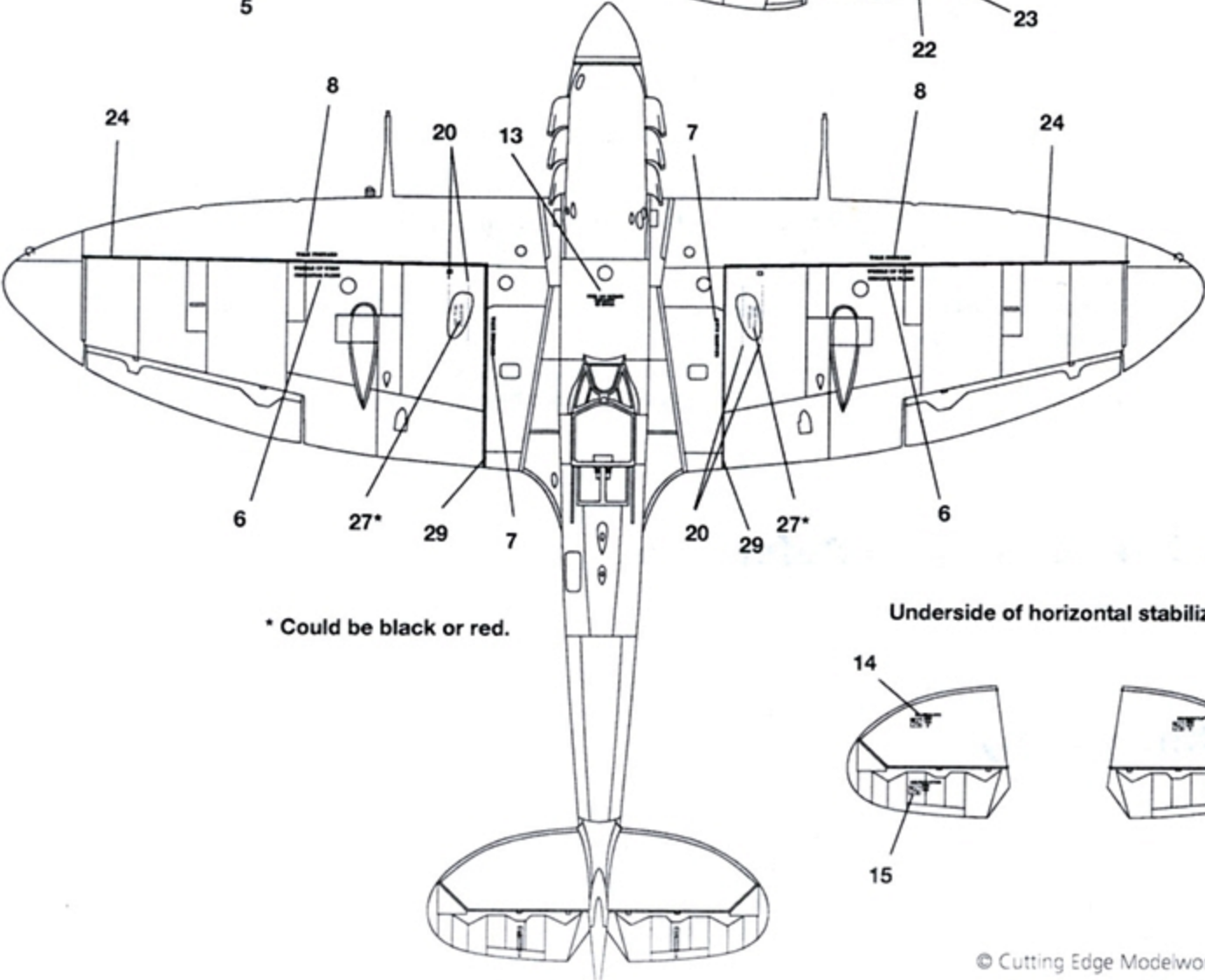
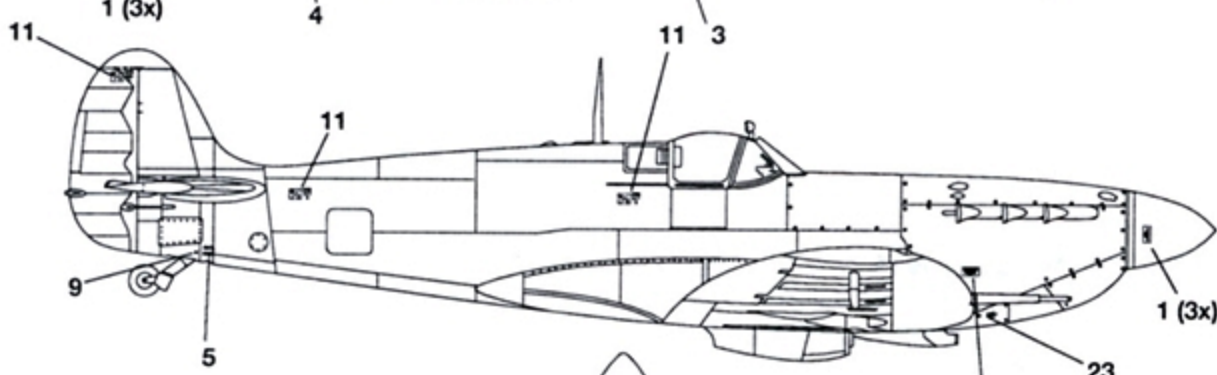
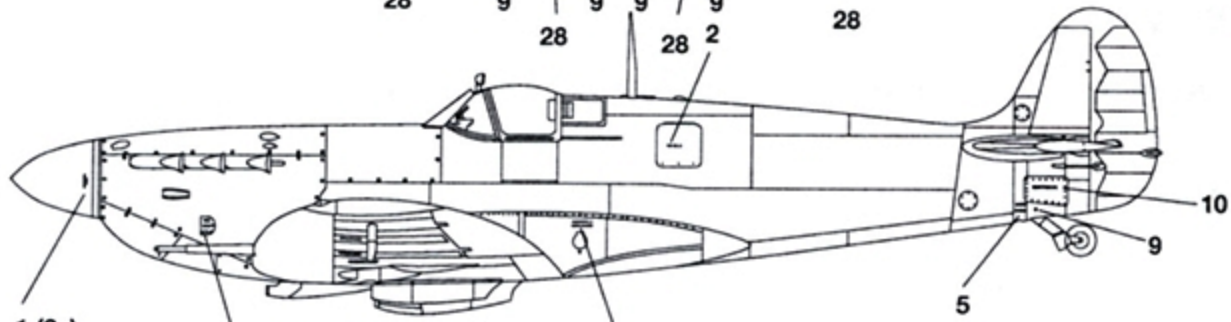
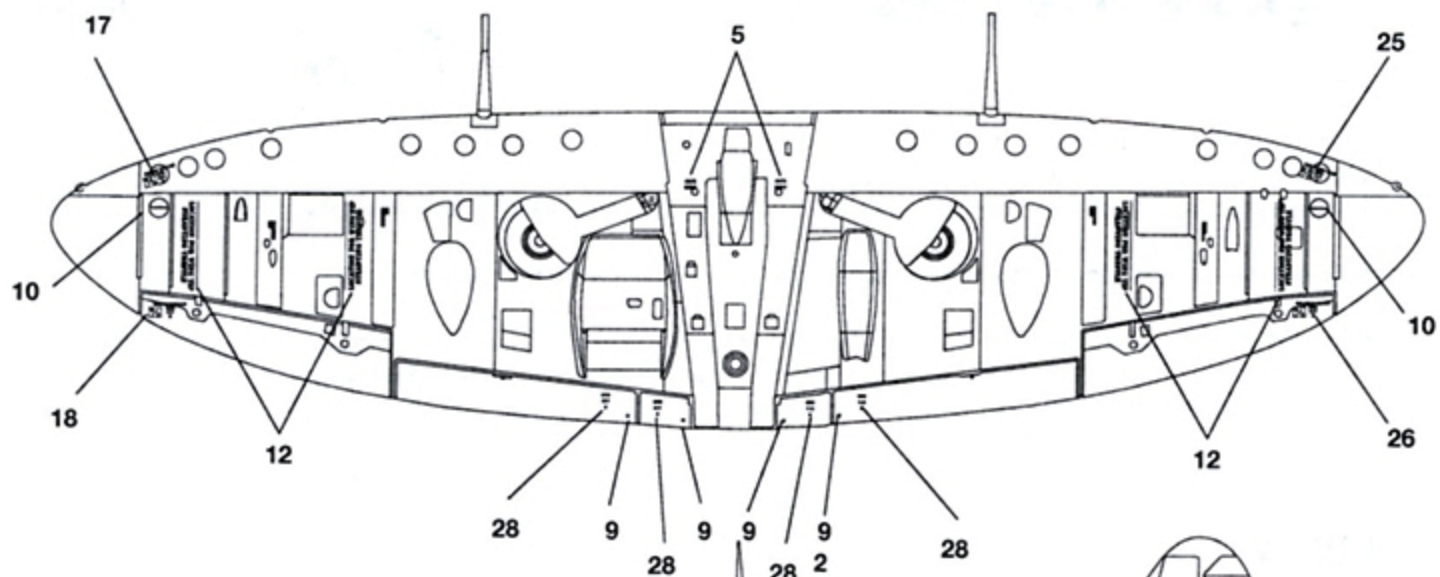

\* Could be black or red.

Underside of horizontal stabilizers

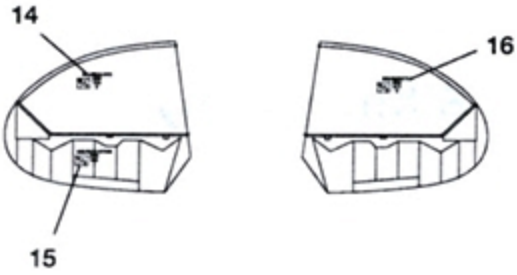





## RS•T

- An often published photo of this aircraft from the right hand side missing the forward cowl/engine appears to show the kill markings on the right hand side of the aircraft. Close examination of the photo reveals that this was not the case, but rather the cover that had the kills on it being applied BACKWARDS on the airframe.
- Codes were slightly shorter than the standard 24". Note these were the pilot's initials.
- On January 28, 1942, he was shot down by German ground fire and attempted to glide to a landing. While attempting this, he came under fire from a German AA gun. Stanford-Tuck managed to fire a quick burst at the gun before crashing, and later learned he sent a bullet down the 20mm gun barrel splitting it open.
- Note that the 'RS' codes were slightly different on each side (labeled on the decal sheet).

## MD•A

- Note that one published reference shows a painted profile of this aircraft with Sea Gray codes which is incorrect.

## MD•C

- Note unusual fuselage cocarde.
- Letter under spinner was likely black.
- Uneven codes were likely a result of being repainted on the fuselage band.
- We could not ascertain the colors of the knight artwork so several options are supplied.

## Applying the Decals

You probably already know all this stuff, so feel free to use your regular process; however, if you're new to aftermarket decals, here goes:

- Generally, use the Microscale Finishing System. We don't recommend extremely strong decal solvents such as Solvaset.
- Your model must have a smooth, glossy surface, as decals won't adhere well to matte surfaces. Use gloss paints or your favorite clear gloss overspray over matte or semigloss paint.
- Cut each subject out without trimming off the slight excess film (this helps the decal film disappear when dry).
- Put the decal in warm water that has a drop or two of liquid dishwashing soap or photo-flo for 10 seconds.
- When the decal will slide off the backing paper without forcing it, apply it to the proper position on your model. Slide the backing paper out from underneath.
- Gently blot off excess water and smooth out bubbles under the decal surface. If you wish, carefully brush on a mild decal softener such as Micro-Sol.
- When all decals are completely dry, gently wash off all excess decal adhesive.
- Finally, overcoat your model with a good quality gloss coat, followed by your choice of matte or eggshell clear topcoat.

## FS 595 Color Cross Reference

Dark Green	Xtracolor X1; Floquil 303143
Ocean Grey	Xtracolor X6; Floquil 303149
Medium Sea Grey	Xtracolor X3; Floquil 303151

## Bibliography

- American Eagles-American Volunteers in the RAF 1937-1943 by Tony Holmes. Classic Publications, 2001.  
Spitfire-The History by E. Morgan and E Shacklady. Key Publishing Ltd., 1987.  
The Debden Eagles, by Garry L. Fry. Walker-Smith, 1970.  
Spitfire In Action, by Jerry Scutts. Squadron/Signal, 1980.  
Eagles of the RAF, by Phillip D. Caine. National Defense University Press, 1991.