

THUNDERCALS

T-004 1/48th Scale P-47D Thunderbolt Razorbacks PTO Part 4 19th, 333rd FS/ 318th FG, Pineapple Air Force

G NEE Oahu, Hawaii, May, 1944
Jeanie (same a/c) Aslito (Isley) Field, June 1944
P-47D-20-RA, 19th FS/318th FG
Pilot 19th FS CO, Maj. Harry McAfee



DAN'L BOONE
P-47D-21-RA 333rd FS. 318 FG
Pilot Capt. Daniel Boone
Aslito (Isley) Field, Saipan, July, 1944

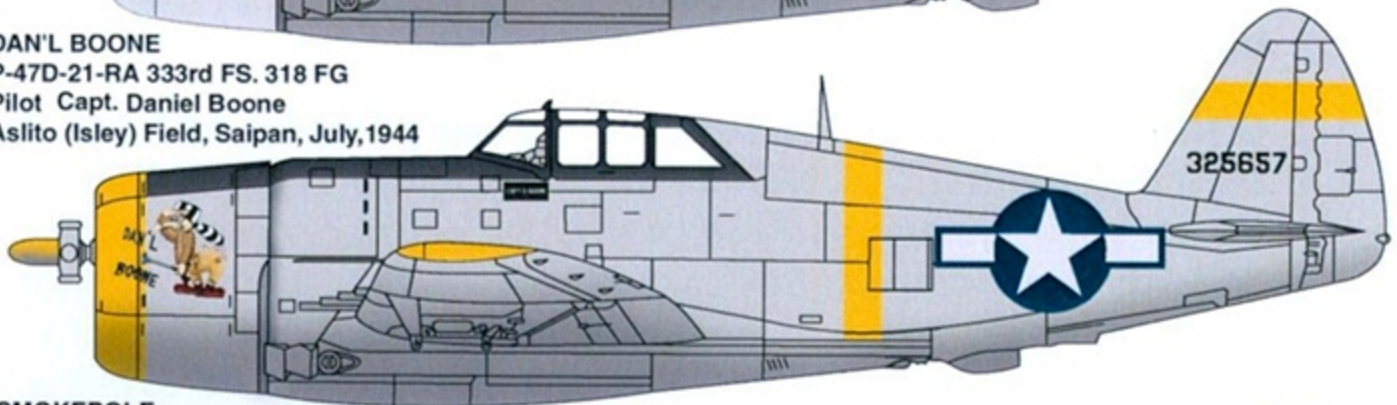

SMOKEPOLE
P-47D-20-RA, 19th FS/318th FG
Pilots: Lt. Hal Dunning & Lt. Doug Towner
CC S/Sgt Eldo E. Lau
Aslito (Isley) Field, Saipan, 1944

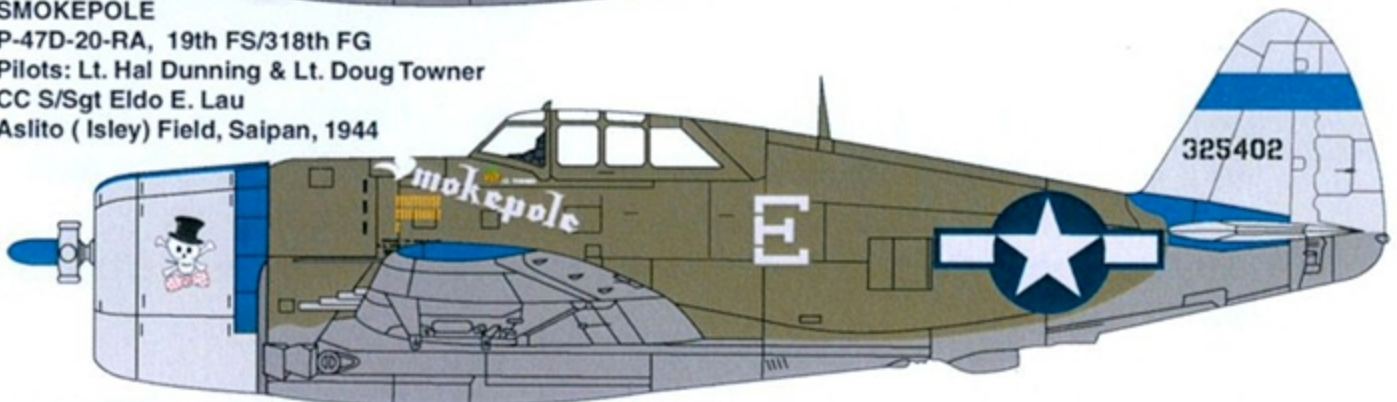

COCKPIT TROUBLE/Rascal
P-47D-20 RA 333rd FS/318 FG
Pilot Unknown
C/C S/Sgt. J. T. Pawlowski
Aslito (Isley) Field, Saipan, 1944

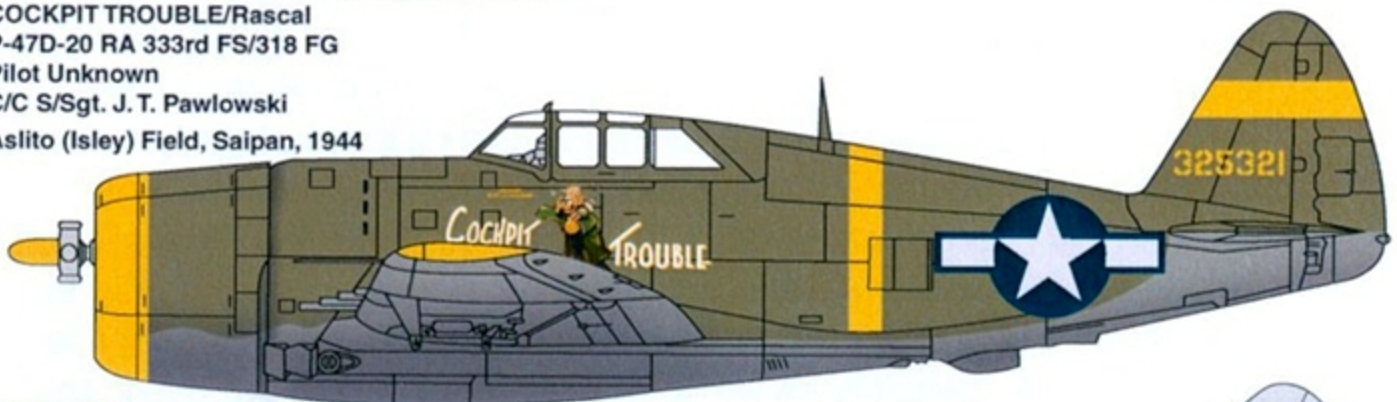

BIG SQUAW
P-47D-20-RA 19th FS/ 318th FG
Pilot Capt. John Vogt
Aslito (Isley)Field, Saipan June, 1944

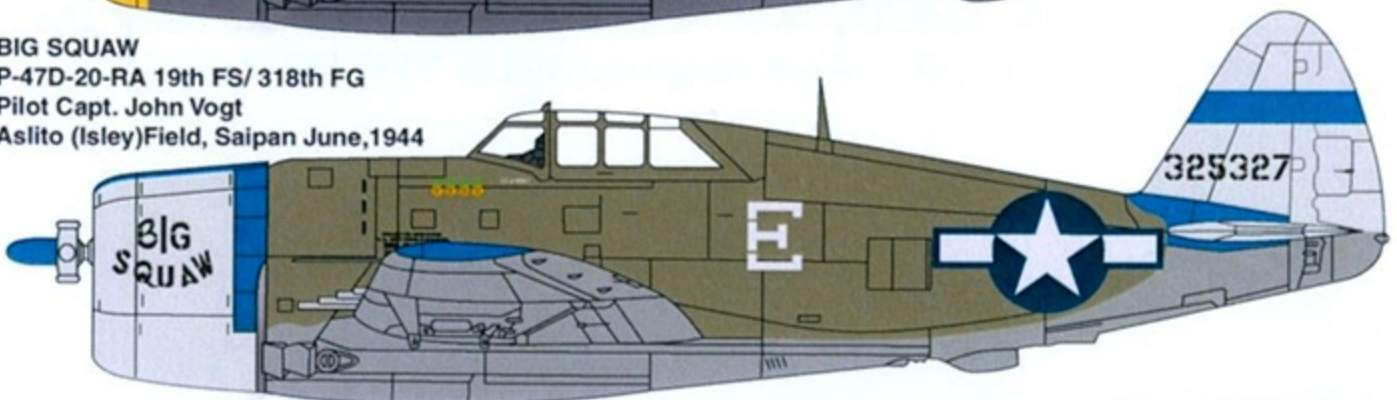

P-47D Razorback Thunderbolts PTO Part 4

Thundercats Decal No. 48-004

G NEE Oahu, Hawaii, May, 1944
 Jeanie (same a/c) Aslito (Isley) Field, June 1944
 P-47D-20-RA, 19th FS/318th FG
 Pilot 19th FS CO, Maj. Harry McAfee

19th FS, 333rd FS/318th FG Pineapple Air Force

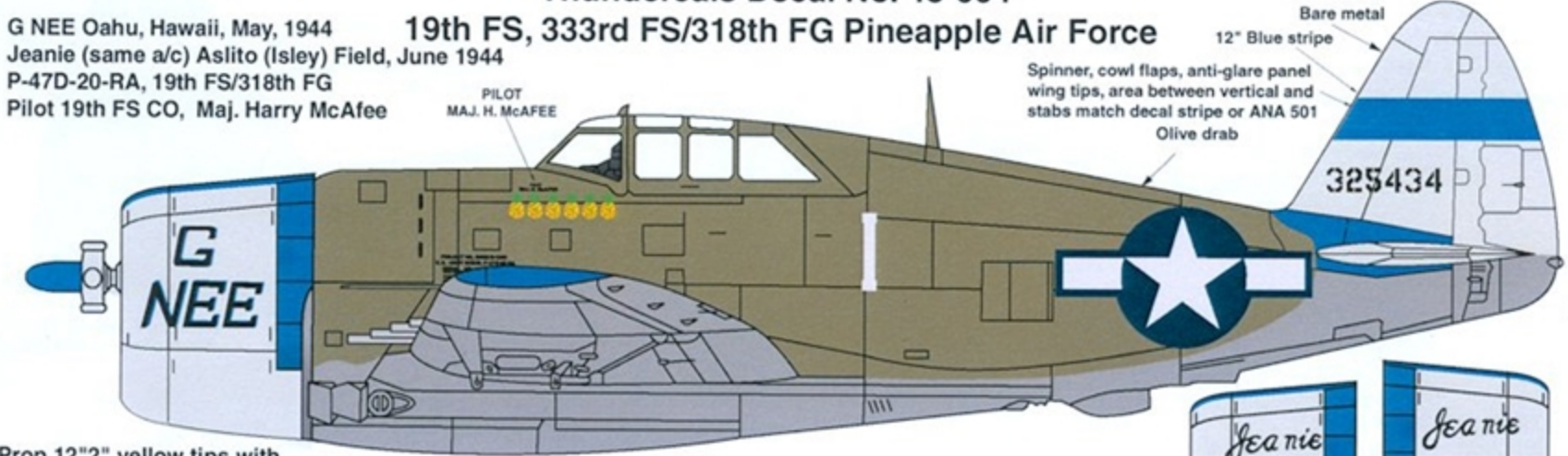

Prop 12"2" yellow tips with black decal pin stripes
 No C.E. logos



12"2" Curtiss Electric Propeller

DAN'L BOONE
 Pilot Capt. Daniel Boone
 P-47D-21-RA 333rd FS/318 FG
 Aslito (Isley) Field, Saipan, July 1944

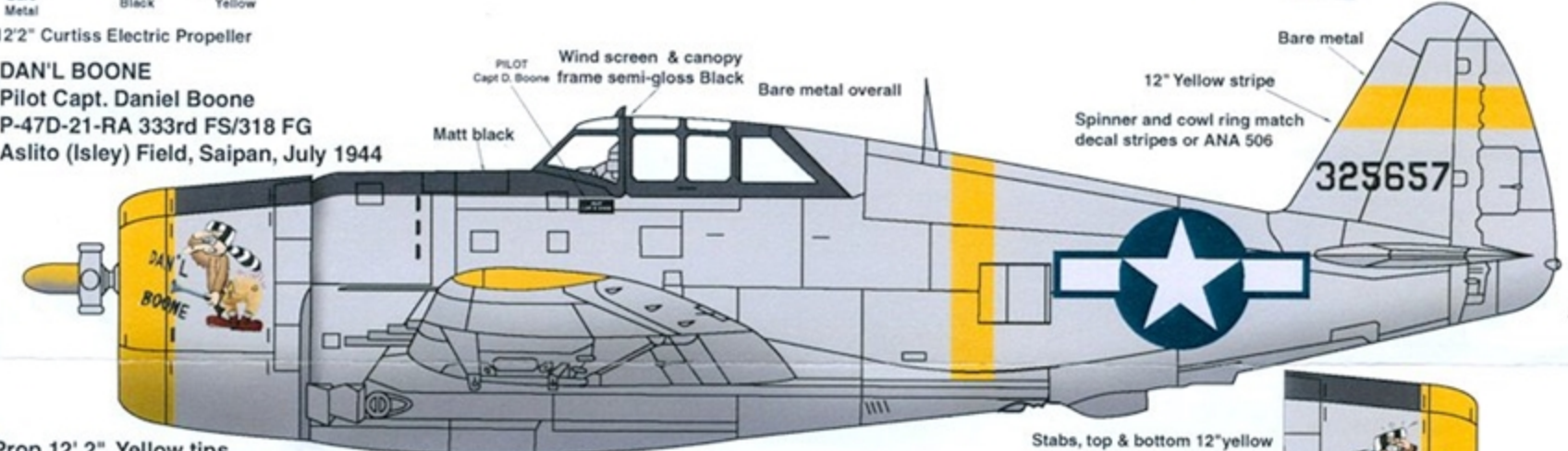

Prop 12' 2", Yellow tips
 C.E. Logo



SMOKEPOLE
 P-47D-20-RA, 19th FS/318th FG
 Pilots: Lt. Hal Dunning & Lt. Doug Towner
 C/C S/Sgt Eido E. Lau
 Aslito (Isley) Field, Saipan, 1944

Same position as pilot name on RT. side

Optional
 LT. DUNNING
 LT. TOWNER

CREW CHIEF
 SMSGT E. LAU

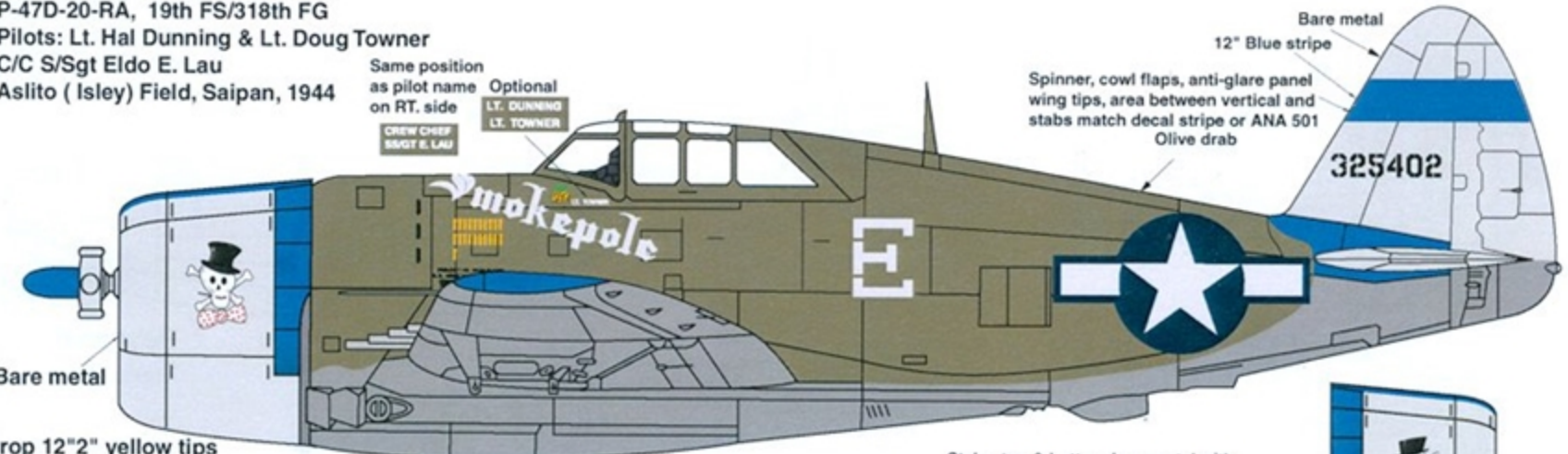

Prop 12"2" yellow tips with black decal pin stripes
 No C.E. logos



12"2" Curtiss Electric Propeller

Neutral Gray
 Blue wheel covers ANA501

Stabs, top & bottom: bare metal with 12" blue decal stripes or ANA501

Decals sized to fit Tamiya 1/48 scale P-47D Razorback but also suitable for the Hasegawa, Otaki and Revell/Monogram 1/48 scale Razorback

Weathering note:

Light weathering on G NEE and DAN'L BOONE
 Heavy weathering on JEANIE, SMOKEPOLE,
 COCKPIT TROUBLE and BIG SQUAW

COCKPIT TROUBLE/Rascal III
 P-47D-20 RA 333rd FS/318 FG
 Pilot Unknown
 C/C S/Sgt. J. T. Pawlowski
 Aslito (Isley) Field, Saipan, 1944

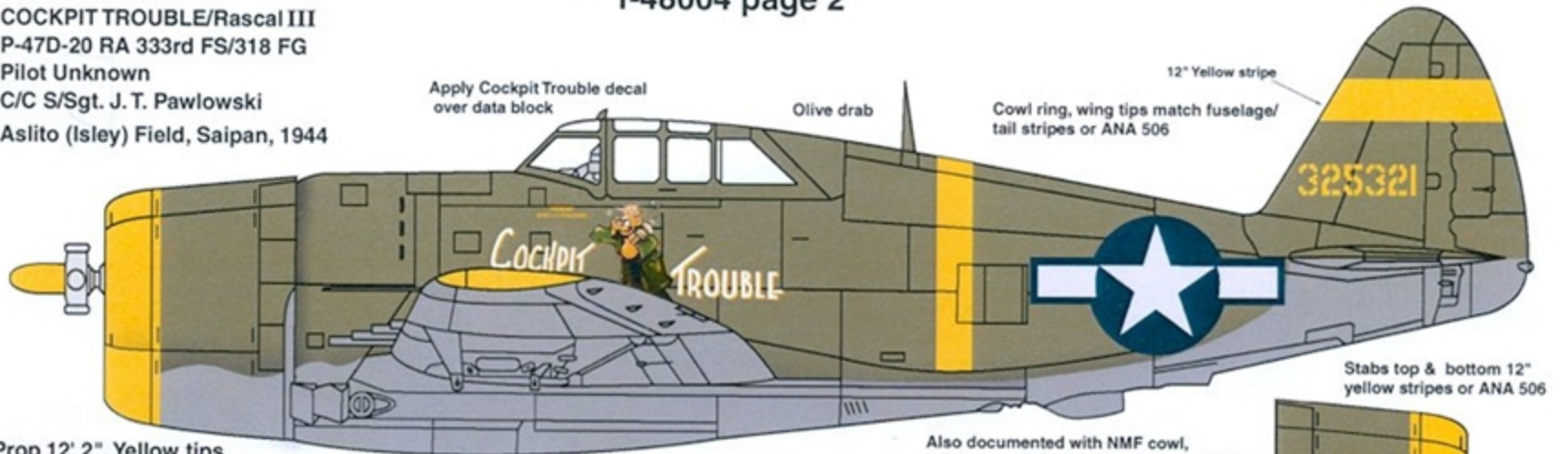

Prop 12' 2", Yellow tips
 No C.E. Logo



Neutral Gray
 Yellow wheel covers



Also documented with NMF cowl,
 yellow cowl ring, but no anti-glare panel

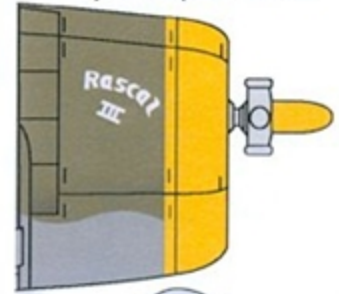

Stabs top & bottom 12"
 yellow stripes or ANA 506

BIG SQUAW
 P-47D-20-RA 19th FS/ 318th FG
 Pilot Capt. John Vogt
 C/C S/Sgt Charlie Walker
 Aslito (Isley)Field, Saipan June,1944

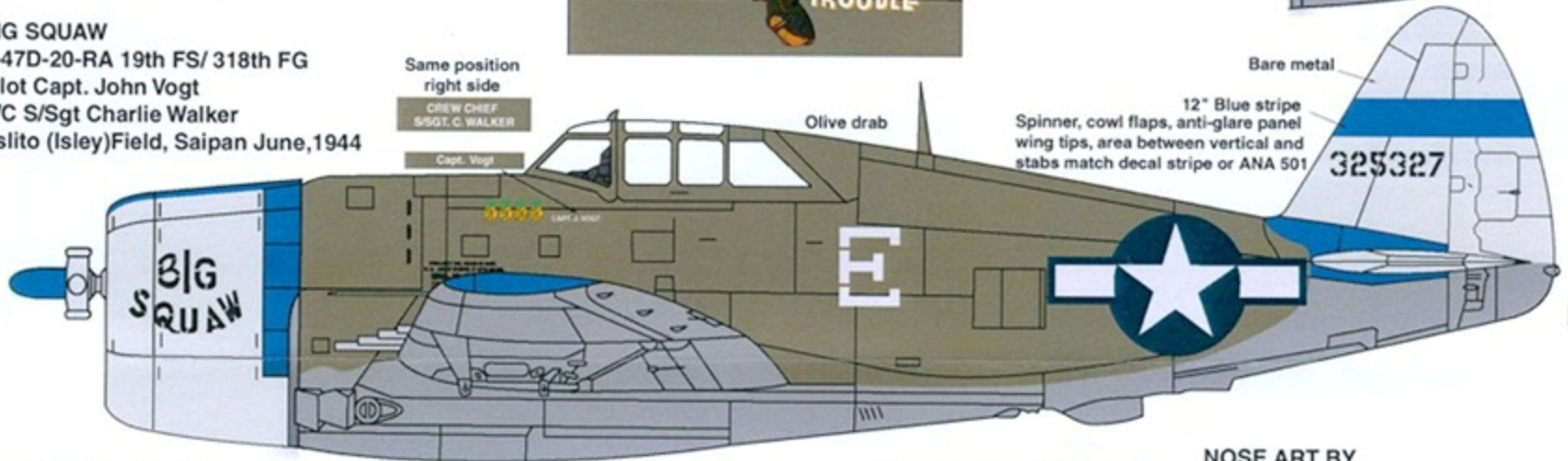

Same position
 right side

CREW CHIEF
 S/Sgt. C. WALKER
 Capt. Vogt

Bare metal

12" Blue stripe
 Spinner, cowl flaps, anti-glare panel
 wing tips, area between vertical and
 stabs match decal stripe or ANA 501

Prop 12'2" yellow tips
 black decal pin stripes
 no C.E. logo



Neutral Gray
 Blue wheel covers ANA501

Data: Comprehensive stenciling/ data is provided for one aircraft. Many razorbacks in the SWP did not utilize a full complement of stenciling. Use the red wing root NO STEPS (28, 29) only on Dan1 Boone.

Stabs, top & bottom: bare metal with
 12" blue decal stripes or ANA501

NOSE ART BY
 Mike Kloppenburg
 Bombshelldecals.com

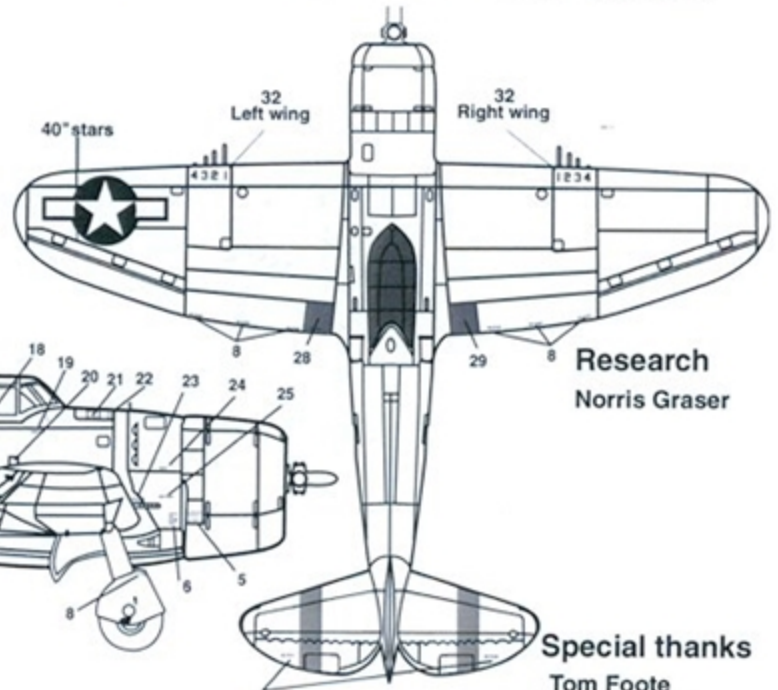
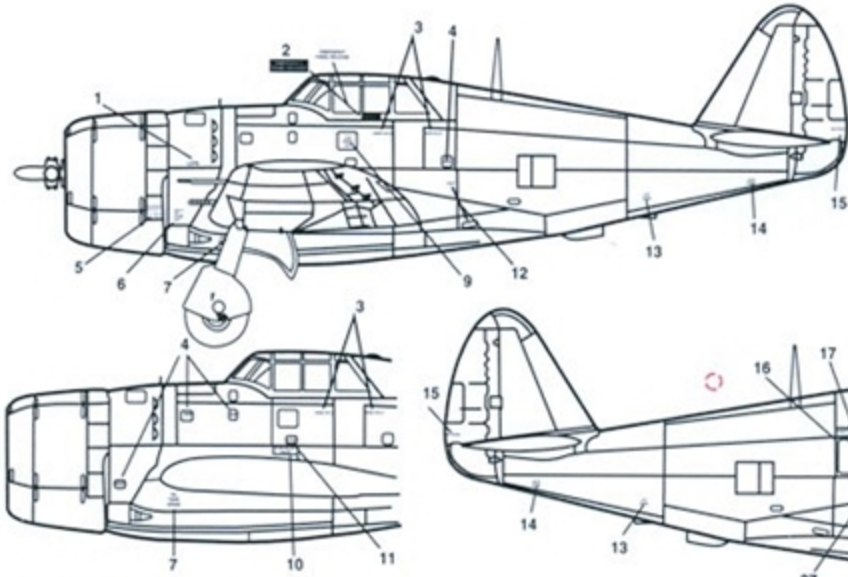
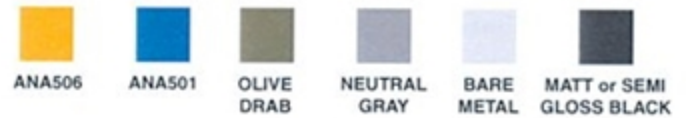

Research
 Norris Graser

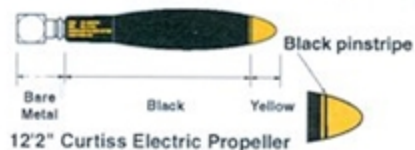
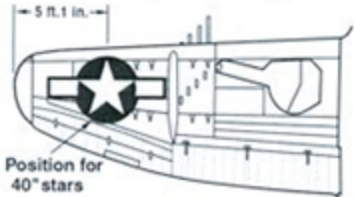

12" stabilizer stripes top & bottom
 Blue 19th FS Yellow 333rd FS

Special thanks
 Tom Foote
 Mike Towner
 Durwood Williams
 (333rd FS/ 318th FG)

318th FG and the Pineapple Air Force

The term "Pineapple Air Force" was affectionately or derogatorily used, depending on each man's point of view, while assigned to the 7th AAF in Hawaii. The units stationed in Hawaii were destination units used as RTU or readiness training units for men being trained before being sent on to the 5AAF & 13AAF known as the "Pacific War Zone". The men who stayed in Hawaii became known as "Pineapples". The 318FG and 19FS in particular, indicated their time in the Pineapple Air force by painting pineapples in place of victory markings on their A/C. Each pineapple signified 6 months served in the "Pineapple" Air force

G NEE / Jeanie 19th FS Assigned to Maj Harry McAfee, 19th FS CO. Most will associate Maj. McAfee with MISS MARY LOU, however, his assigned aircraft was P-47D 43-25434, originally painted as G NEE while on Oahu. On Saipan, the same aircraft featured a simple handwritten "Jeanie" on both sides of the cowling. Minimal wear for G NEE, heavy weathering for Jeanie. 6 Pineapples = 3 years in the Pineapple Air Force

DAN'L BOONE 333rd FS Assigned to Capt. Daniel Boone. Over all NMF as it arrived on Saipan. Artwork by Lt Robert Reiser, who also applied his talent to several other 333rd P-47's, including his razorback, AIR COOLED INJUN. Light to medium weathering on this NMF Thunderbolt.

Boone # 2 This is the same P-47 as above, but now in an unusual scheme for the 333rd FS. The only info available is a single side image of this P-47 taxiing. It cannot be determined whether the vertical fin and rudder are O.D or black. Definitely photographed at a later time, it is possible that the tail is an O.D. replacement from another P-47 as the plane did suffer damage to the tail. The original serial (325567) was re-stenciled in yellow. It is also possible the tail was repainted in black retaining the yellow stripe, sometime in late 1944 or 1945, possibly as an attempt to identify with the black and yellow zebra striped tail markings applied to 318th FG P-47N's.

SMOKEPOLE 19th FS Originally assigned to Hal Dunning. After Lt Dunning cycled out, it was assigned to Lt. Harwood "Doug" Towner. The Crew Chief was S/Sgt. Eldo Lau. All markings were applied after reaching Isley Field when assigned to Lt. Dunning. Although Lt. Towner inherited the markings, he did not change or add to them. Weathering on SMOKEPOLE was moderate for Lt. Dunning and heavy for Lt. Towner. 1 Pineapple = 6 months in the Pineapple Air Force

COCKPIT TROUBLE 333rd FS Assigned pilot is unknown for this P-47. The crew chief was S/Sgt. J.T.Pawlowski. It is obviously included because of the interesting artwork, created by Lt Robert Reiser. "Rascal III" appears on the right side cowl. At some point the plane utilized a NMF cowling with typical yellow cowl ring but no anti-glare. Moderate weathering. Heavier weathering, especially after receiving the NMF cowl.

BIG SQUAW 19th FS Assigned to Capt. John Vogt until receiving his P-47N, DRINK N' SISTER. Capt. Vogt would later replace Maj. McAfee as CO. The Crew Chief was S/Sgt. Charles Walker. Weathering on BIG SQUAW included plenty of wear and tear. Capt. Vogt later became an "ace in a day" flying the P-47N. 4 pineapples = 2 years in the Pineapple Air Force

References

"Seventh Air Force Story", Kenn C. Rust, Sunshine House, 1979
"The Pineapple Air Force", John W. Lambert, Schiffer, 2006
"Thunderbolt in the Pacific Theater", Ernest McDowell, Squadron Signal Publications 1999

Recommended

"Profile Hanger No 1" Landscape Pub., 2012: Twenty four page section featuring images and profiles for the 19th FS razorbacks. Recommended only for the many pictures and well done color profiles for weathering. Profiles include Smokepole and Big Squaw.

Research: Norris Graser

Special thanks: Tom Foote and Durwood Williams.

We are always looking for more Thunderbolts.

Contact us at Thundercals@yahoo.com

DAN'L BOONE
 Pilot. Capt Daniel Boone
 P-47D-21-RA 333rd FS/ 318 FG

