

8475
1:48

Avia B-534 IV.série

eduard
WEEKEND
EDITION

PLASTIC PARTS

A>

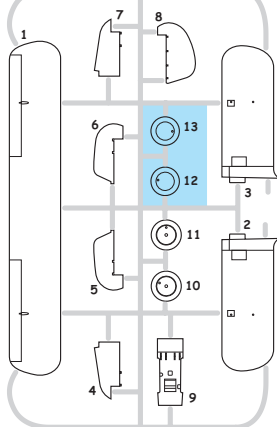

B>

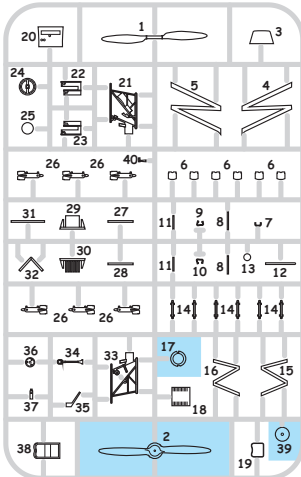

C>

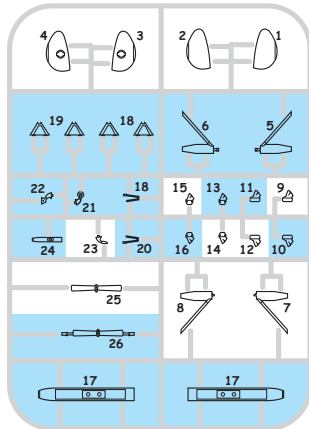

E>

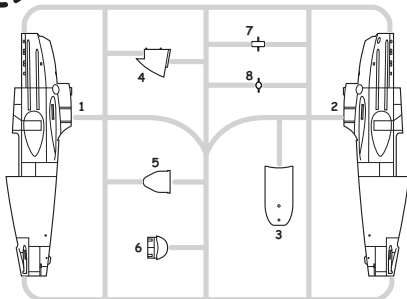

F>

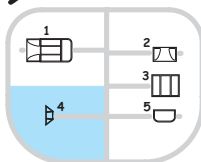

Mr. METAL COLOR	
MC211	CHROME SILVER
MC214	GUN METAL
MC215	COPPER
MC218	ALUMINIUM

Mr.COLOR	
C005	BLUE
C006	GREEN
C007	BROWN
C008	SILVER
C011	LIGHT GULL GRAY
C017	BLACK GREEN
C033	FLAT BLACK
C041	RED BROWN
C043	WOOD BROWN
C062	WHITE
C078	METAL BLACK
C137	TIRE BLACK
HOBBY COLOR	
H80	KHAKI

ATTENTION * UPOZORNĚNÍ * ACHTUNG * ATTENTION

(GB)

Carefully read instruction sheet before assembling. When you use glue or paint, do not use near open flame and use in well ventilated room. Keep out of reach of small children. Children must not be allowed to suck any part, or pull vinyl bag over the head.

(CZ)

Před započatím stavby si pečlivě prostudujte stavební návod. Při používání barev a lepidel pracujte v dobře větrané místnosti. Lepidla ani barvy nepoužívejte v blízkosti otevřeného ohně. Model není určen malým dětem, mohlo by dojít k požití drobných dílů.

(D)

Von dem Zusammensetzen die Bauanleitung gut durchlesen. Kleber und Farbe nicht nahe von offenem Feuer verwenden und das Fenster von Zeit zu Zeit Belüftung öffnen. Bausatz von kleinen Kindern fernhalten. Verhüten Sie, daß Kinder irgendwelche Bauteile in den Mund nehmen oder Plastiktüten über den Kopf ziehen.

(F)

lire soigneusement la fiche d'instructions avant d'assembler. Ne pas utiliser de colle ou de peinture à proximité d'une flamme nue, et aérer la pièce de temps en temps. Garder hors de portée des enfants en bas âge. Ne pas laisser les enfants mettre en bouche ou sucer les pièces, ou passer un sachet vinyl sur la tête.

INSTRUCTION SIGNS * INSTR. SYMBOL * INSTRUKTION SINNBILDEN * SYMBOLES



OPTIONAL
FACULTATIF
NACH BELIEBEN
VOLBA



BEND
PLIER SIL VOUS PLAIT
BITTE BIEGEN
OHNOUT



OPEN HOLE
FAIRE UN TROU
OFFNEN
VYVRTAT OTVOR



SYMETRICAL ASSEMBLY
MONTAGE SYMÉTRIQUE
SYMMETRISCHE AUFBAU
SYMETRICKÁ MONTÁŽ



NOTCH
L INCISION
DER EINSCHNITT
ZÄREZ



REMOVE
RETIRER
ENTFERNEN
ODRÍZNOUT

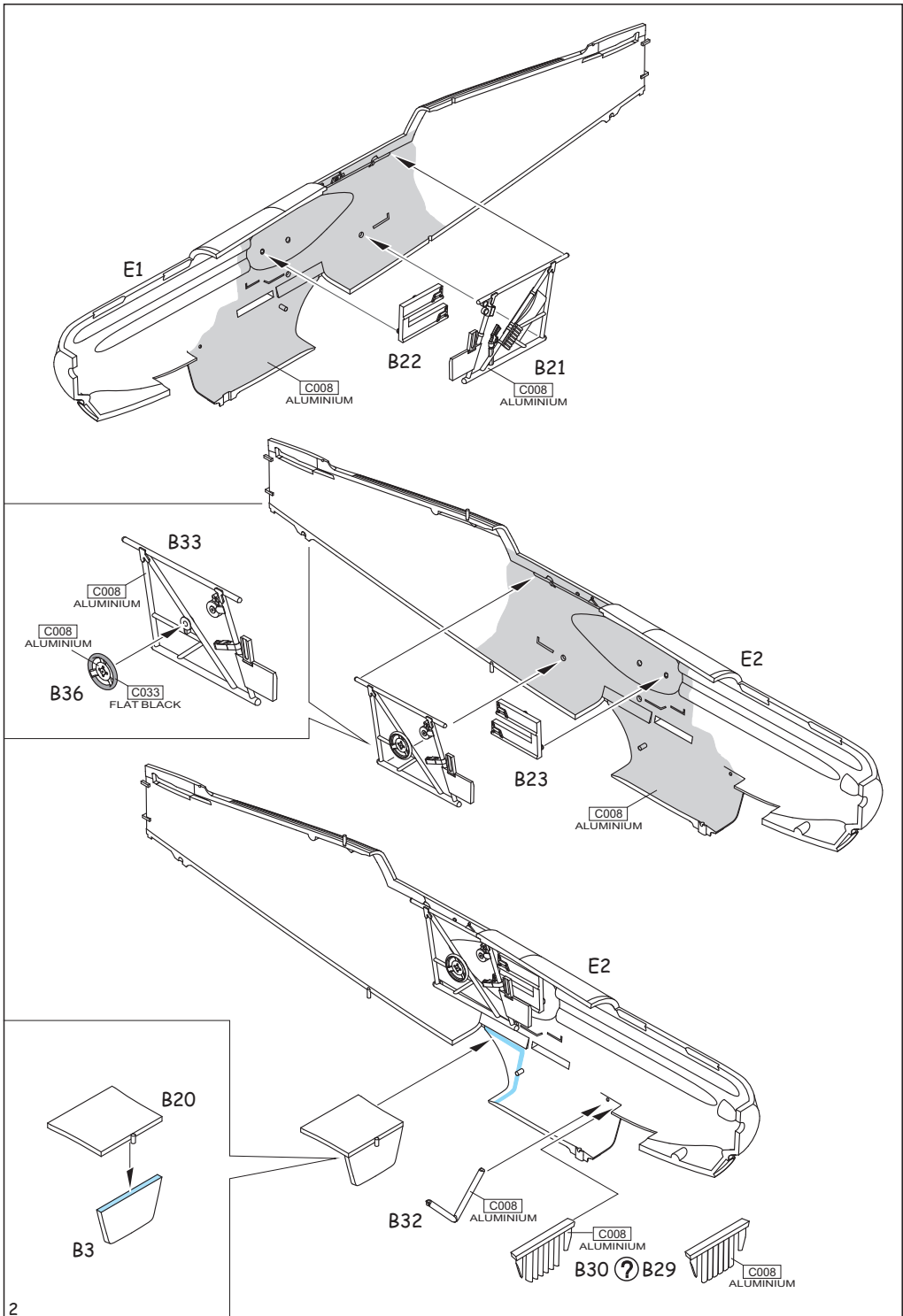

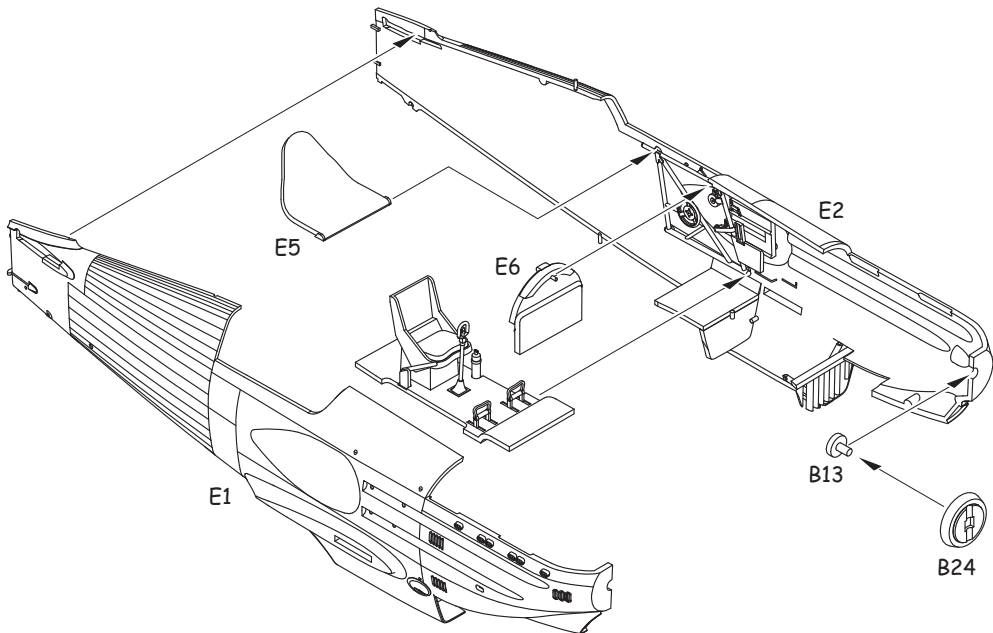
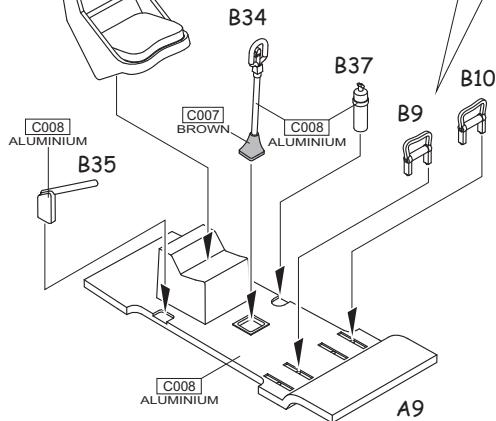
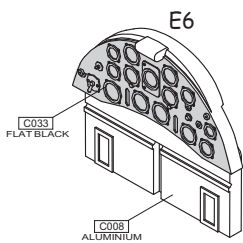
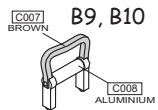
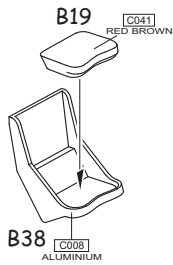

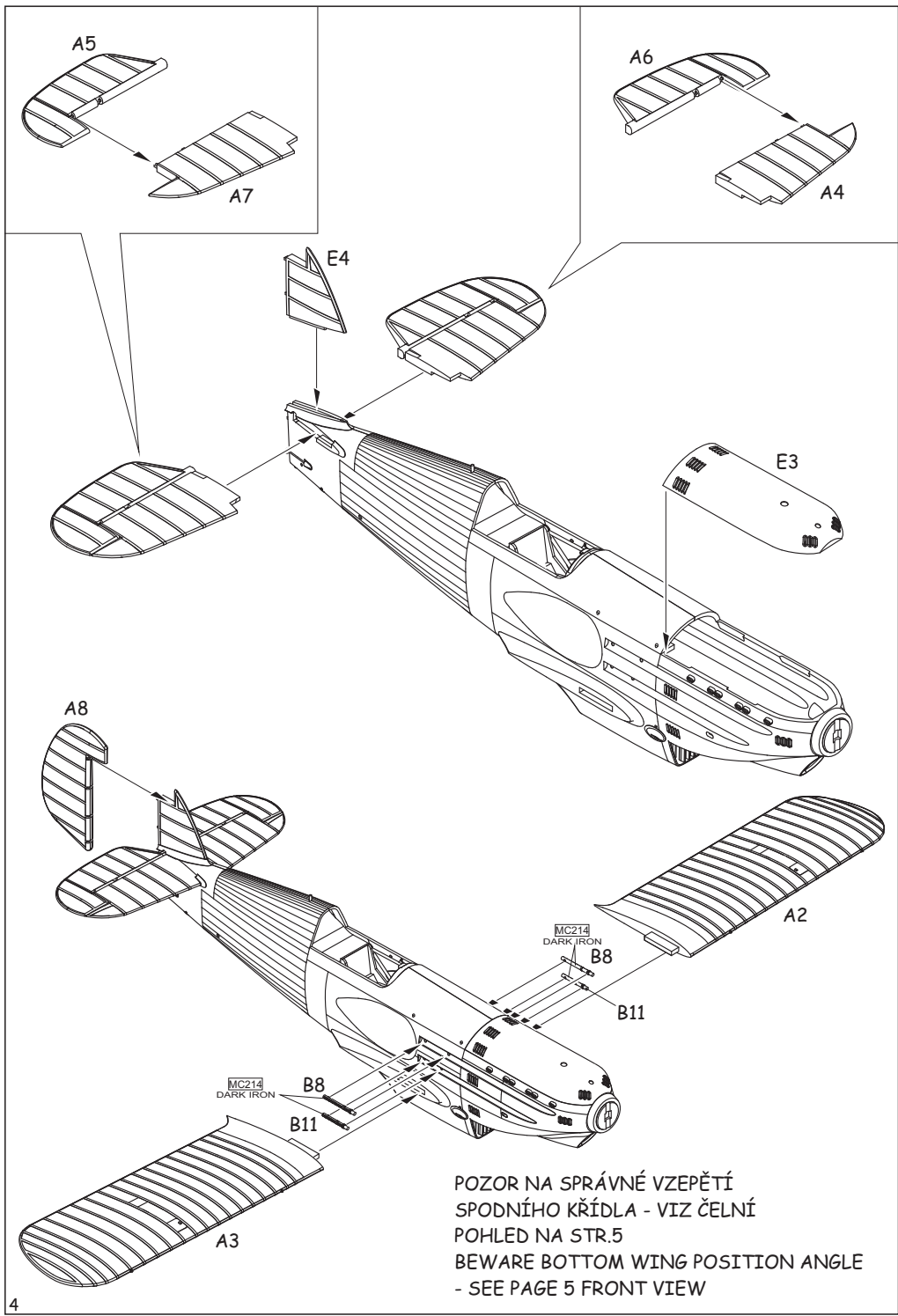

POZOR NA SPRÁVNÉ VZEPĚTÍ
 SPODNÍHO KŘÍDLA - VIZ ČELNÍ
 POHLED NA STR.5
 BEWARE BOTTOM WING POSITION ANGLE
 - SEE PAGE 5 FRONT VIEW

POZOR NA SPRÁVNOU ORIENTACI A POZICI
VZPĚŘ!
BEWARE CORRECT STRUT POSITION!

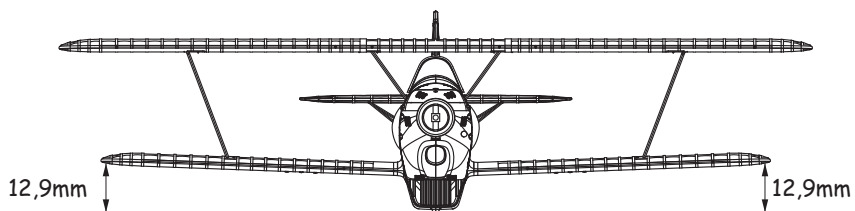
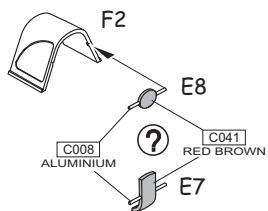
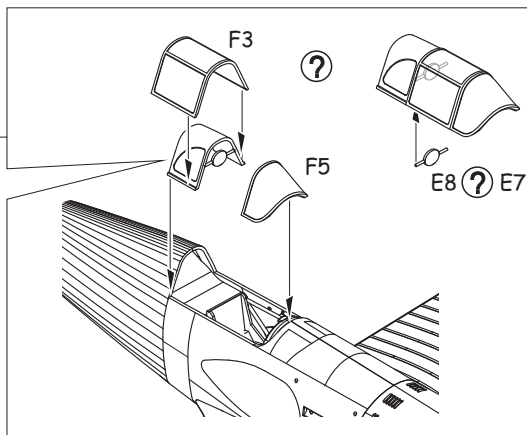
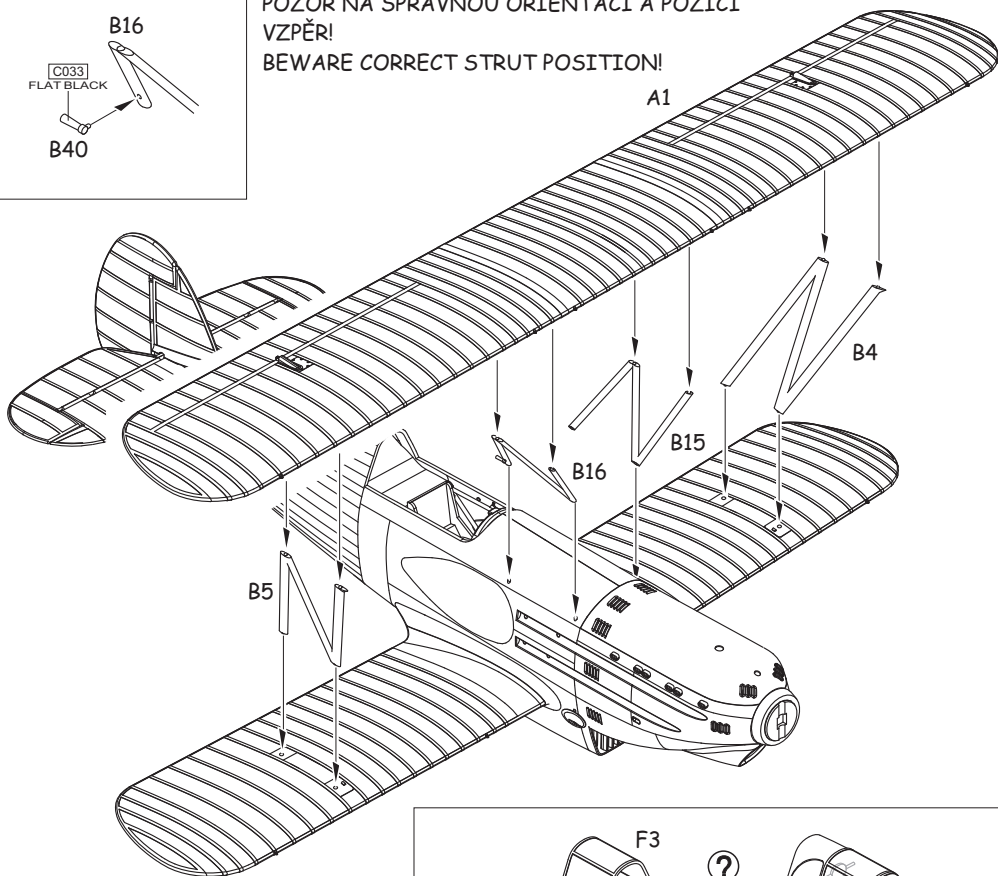
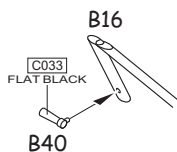

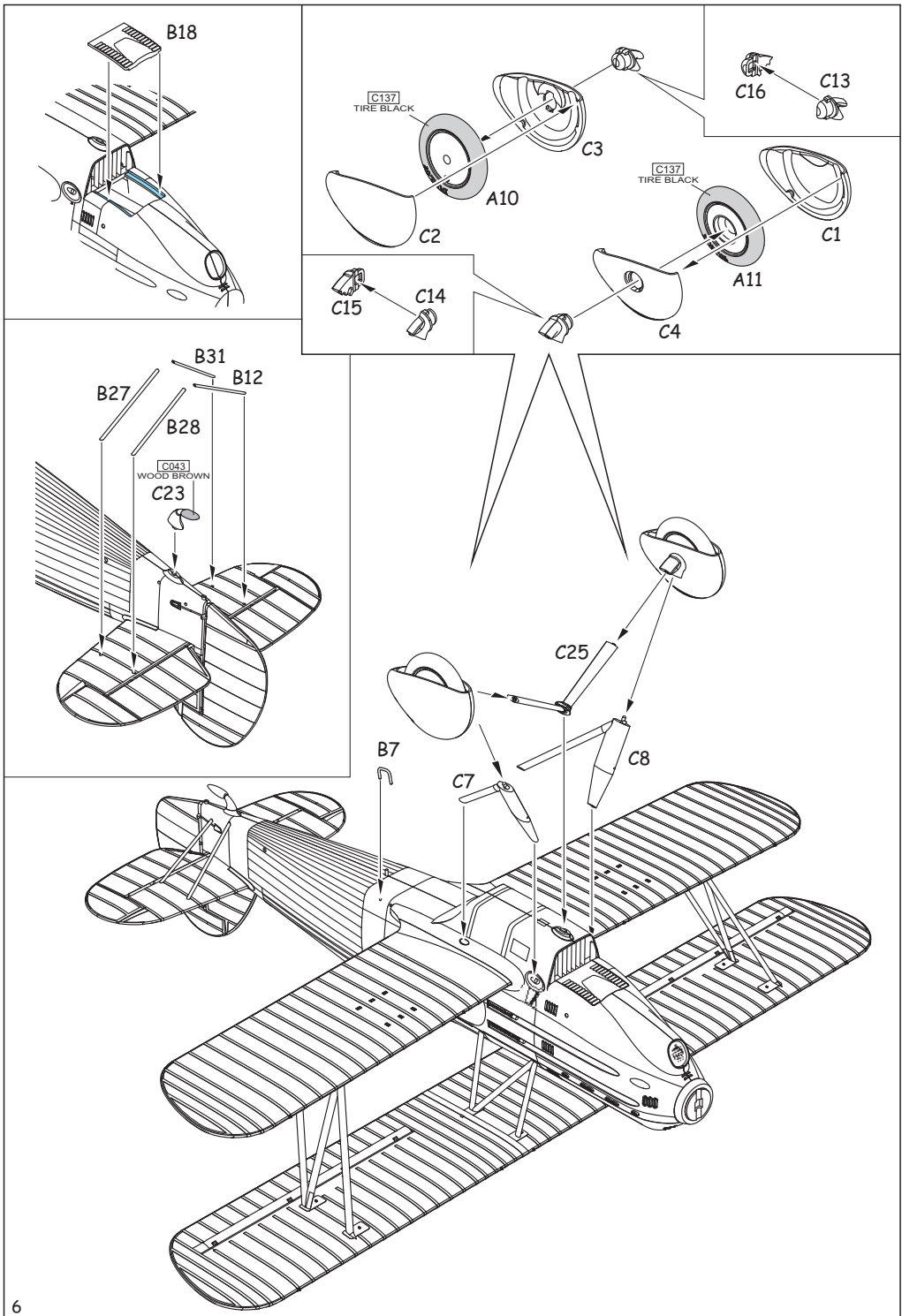

6 pcs.

B26

C017 BLACK GREEN ? C033 FLAT BLACK

B6

B14

C008 ALUMINIUM

3 pcs.

3 pcs.

B1

B17

C008 ALUMINIUM

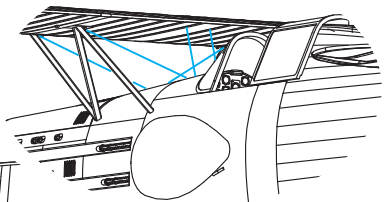
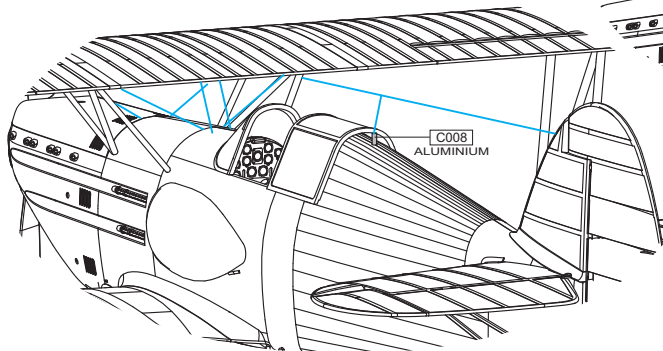
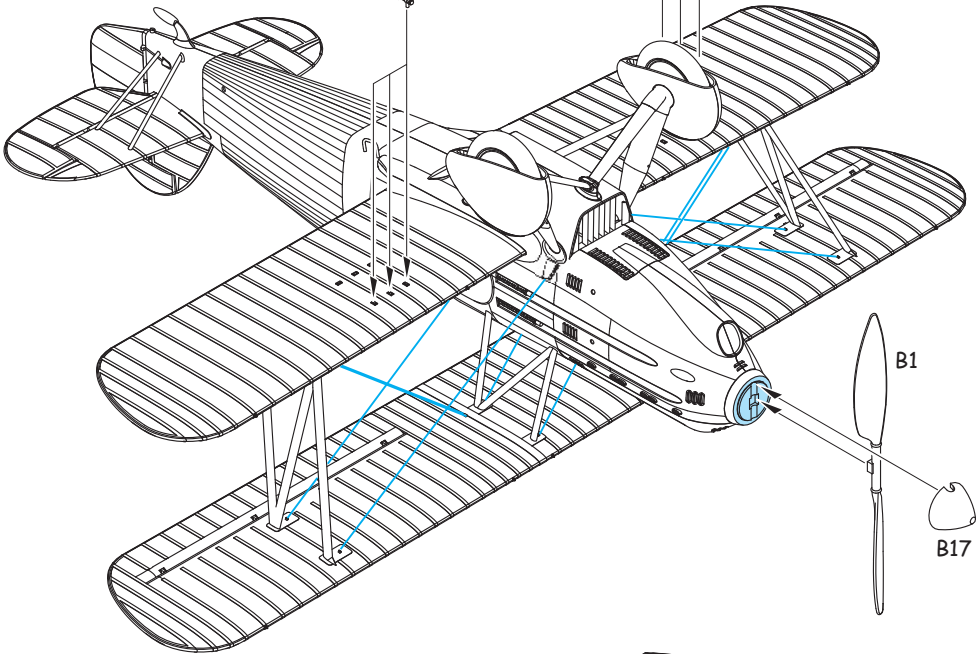

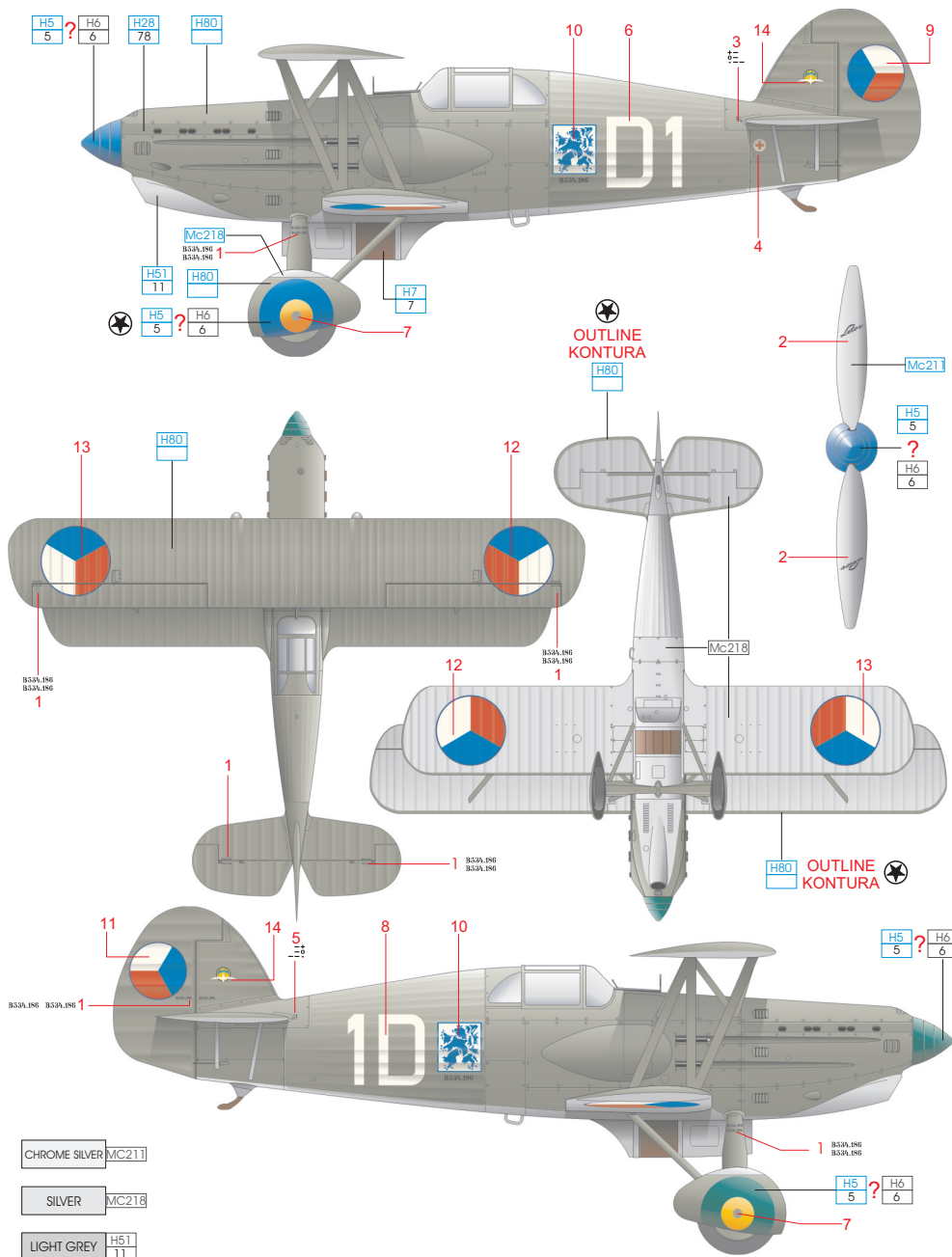

CHROME SILVER MC211

SILVER MC218

LIGHT GREY H51 11

GREEN H6 6

BLUE H5 5

BROWN H7 7

KHAKI GREEN H80

METAL BLACK H28 78

FIND FULL COLOR INSTRUCTION ON WWW.EDUARD.COM

CELOBAREVNÝ NÁVOD NA WWW.EDUARD.COM

