



KIT 5241

85524100200

# P-51D MUSTANG

North American Aviation created the P-51 Mustang in response to a British requirement during 1940. Originally powered by an Allison V-1710 engine, P-51B and P-51C versions were the first to be equipped with a Rolls Royce Merlin powerplant which greatly increased performance at high altitudes. Additional improvements appeared on the P-51D, which this kit represents. A bubble canopy was fitted on a cut down fuselage spine, and this provided excellent visibility for the pilot. Firepower was increased from four .50-caliber machine guns in the P-51B/C to six in the P-51D. The P-51D was the final Mustang variant to see combat during World War II, and it was considered to be one of the most successful fighters of that era.

Two sets of markings are provided with this kit of the P-51D. One is Big Beautiful Doll, which was flown by Lt. Col. John D. Landers while he was assigned to the 84th fighter Squadron of the 78th Fighter Group. Landers was the 78th Fighter Group's commanding officer, and he is credited with 14.5 victories. The second aircraft, Miss Marilyn II, was assigned to the 343rd Fighter Squadron of the 55th fighter Group. It was flown by 1st Lt. Robert Welch who scored six confirmed kills.

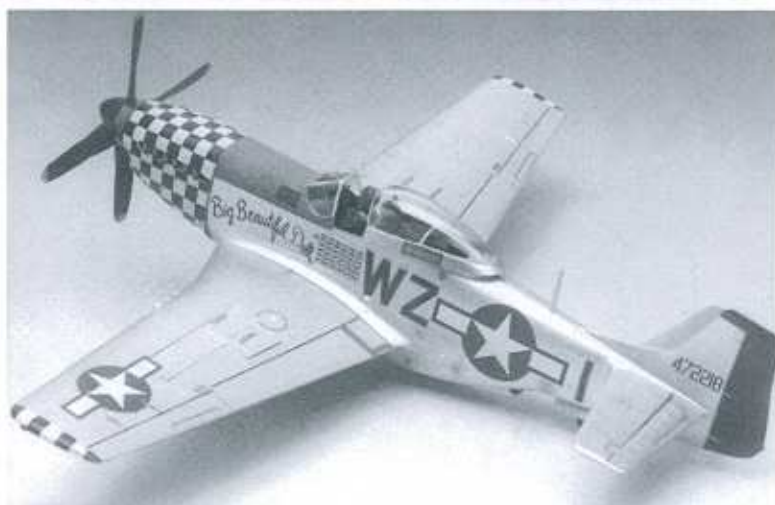

\* REPEAT SEVERAL TIMES  
\* A REPETER PLUSIEURS FOIS



\* OPTIONAL PARTS  
\* PIÈCES EN OPTION



\* DECAL  
\* DECAL COMANIE



\* ALTERNATIVE ASSEMBLY  
\* ENSEMBLAGE ALTERNATIVE



\* CEMENT TOGETHER  
\* A COLLER



\* REMOVE AND THROW AWAY  
\* A RETIRER ET JETER



\* DO NOT CEMENT  
\* NE PAS COLLER

## READ THIS BEFORE YOU BEGIN

- Study the assembly drawings.
- Each plastic part is identified by a number.
- In the assembly drawings, some parts will be marked by a star (★) to indicate chrome plated plastic.
- For better paint and decal adhesion, wash the plastic parts in a mild detergent solution. Rinse and let air dry.
- Check the fit of each piece before cementing in place.
- Use only cement for polystyrene plastic.
- Scrape plating and paint from areas to be cemented.
- Allow paint to dry thoroughly before handling parts.
- Any unused parts may be discarded.

## DECAL APPLICATION INSTRUCTIONS

1. Cut desired decal from sheet.
2. Dip decal in water for a few seconds.
3. Place wet decal on paper towel.
4. Wait until decal is movable on paper backing.
5. Place decal in position on model, face up and slide backing away.
6. Press out air bubbles with a soft damp cloth.
7. Milkyness that may appear is for better decal adhesion and will dry clear. Wipe away any excess adhesive.
8. Do not touch decal until fully dry.
9. Allow the decals 48 hours to dry before applying clear coat.

**NOTE:** Decals are compatible with setting solutions or solvents.

## LIRE CE QUI SUIT AVANT DE COMMENCER

- Etudier les schémas de montage.
- Chaque pièce en plastique est identifiée par un numéro.
- Sur les schémas de montage, certaines pièces sont marquées d'une étoile (★) pour indiquer qu'elles sont en plastique chromé.
- Pour une meilleure prise de la peinture et des autocollants, laver les pièces en plastique avec une solution détergente peu concentrée. Les rincer et les laisser sécher à l'air.
- Vérifier que chaque pièce s'ajuste bien avant de la coller en place.
- N'utiliser que de la colle pour polystyrène.
- Gratter les parties à coller pour enlever le chrome et la peinture.
- Laisser la peinture bien sécher avant de manipuler les pièces.
- Toute pièce inutilisée peut être jetée.

## DIRECTIVES D'APPLICATION DES AUTOCOLLANTS

1. Découper l'autocollant désiré de la feuille.
2. Tremper l'autocollant dans de l'eau pendant quelques secondes.
3. Placer l'autocollant mouillé sur une serviette en papier.
4. Attendez que l'autocollant puisse être déplacé sur son support en papier.
5. Mettre l'autocollant en position sur le modèle face sur le dessus et faire glisser le support pour l'enlever.
6. Appuyer avec un chiffon doux humide pour éliminer les bulles d'air.
7. La substance laiteuse qui peut apparaître est destinée à améliorer l'adhésion de l'autocollant et devient incolore au séchage. Essuyer pour enlever tout excédent d'adhésif.
8. Ne pas toucher l'autocollant tant qu'il n'est pas bien sec.
9. Laisser l'autocollant sécher pendant 48 heures avant d'appliquer une couche transparente.

**REMARQUE:** Les autocollants sont compatibles avec les solutions de fixage ou les solvants.

**This paint guide is provided to complete this kit as shown on the box.**

Ce guide de peinture est fourni pour reproduire le modèle réduit qui apparaît sur la boîte.

Flat Black	Noir mat
Red	Rouge
Green	Vert
Yellow	Jaune
White	Blanc
Chromate Yellow	Jaune chromate
Gray	Gris
Olive Drab	Gris olivé
Chromate Green	Vert chromate
Silver	Argent
Aluminum	Aluminium
Steel	Acier
Brown	Brun
Flesh	Chair
Brass	Laiton
Khaki	Ocre

If you have any questions or comments, call our hotline at: **(800) 833-3570** or, please write to:

**Revell-Monogram Consumer Service Department, 725 Landwehr Road, Northbrook, Illinois 60062**

Be sure to include the plan number (85524100200), part number, description, your return address and phone number.

Visit our website: [www.revellmonogram.com](http://www.revellmonogram.com)

**RECOMMENDED REFERENCE:** A reference book which will prove very helpful in building this model of the P-51D Mustang is The P-51 Mustang in Detail & Scale, Part 2. This book has scores of detailed photographs of the P-51 including color pictures of the cockpit interior, gun bays, landing gear, and engine compartment. This book can be found at better hobby shops, aviation bookstores, and mail order houses. If it is not available in your area, contact Squadron/Signal Publications at 1115 Crowley Drive, Carrollton, Texas 75011-5010, or call (972) 242-8663. Ask for book number 8251.

## STEP 1, COCKPIT ASSEMBLY



Details of the instrument panel and throttle are shown here.  
(Detail & Scale photo by Bert Kinzey)



The top of the seat, armor, and head rest are visible in this photograph.  
(Detail & Scale photo by Bert Kinzey)

NOTE: ProModeler after-market decal sheet number 88-1014 provides instrument panel decals and decals of individual instruments for the P-51 Mustang. These decals are accurate and highly realistic. The instruments even appear to be under glass. You can find this decal sheet at better hobby shops and mail order houses. It will simplify the detailing of the cockpit and make your model look more realistic.

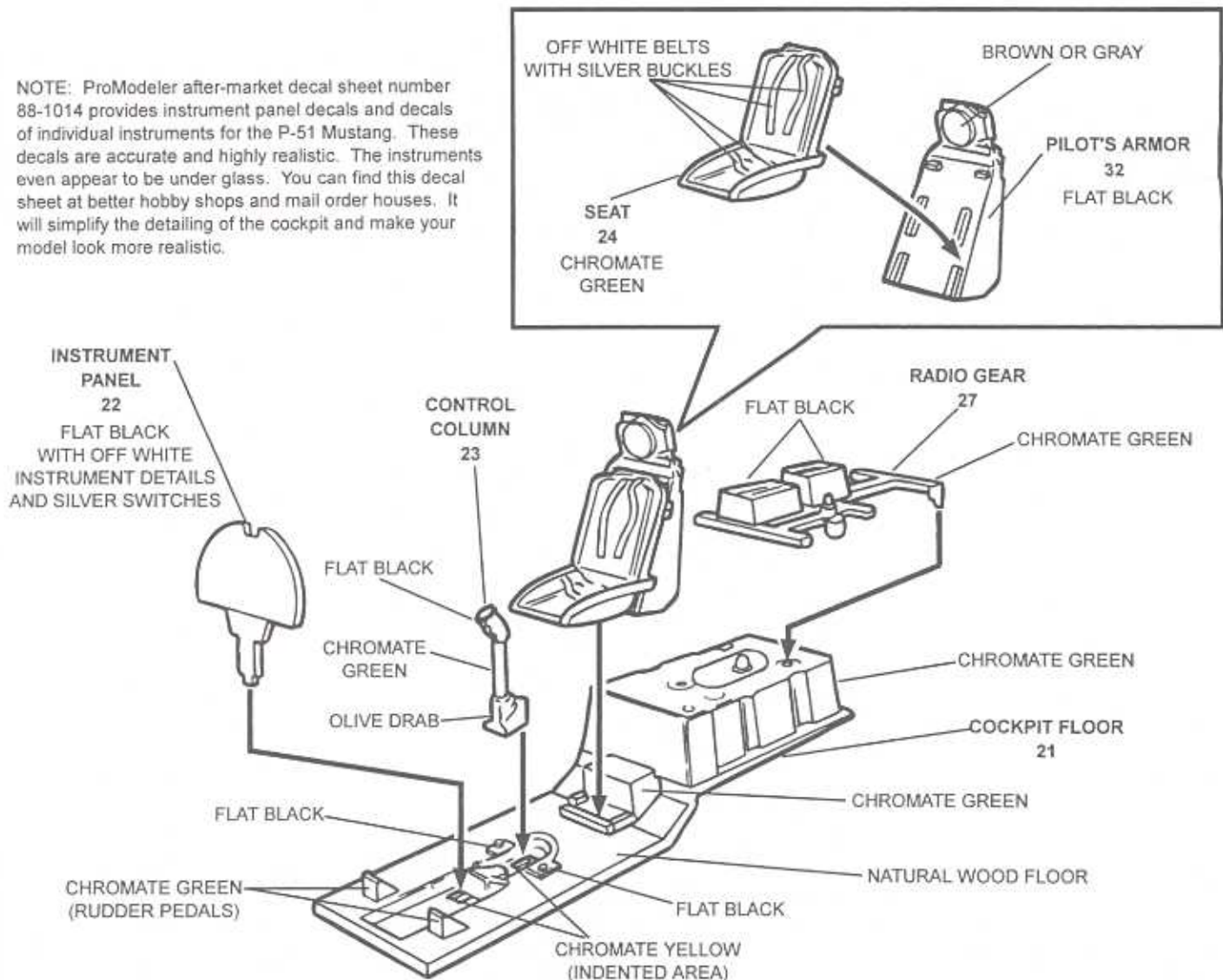

# STEP 2, FUSELAGE ASSEMBLY

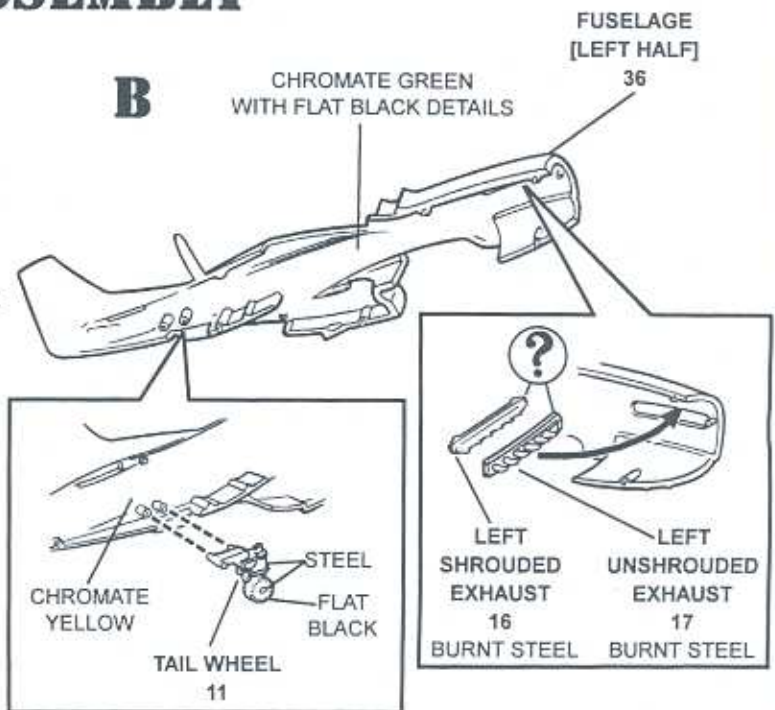
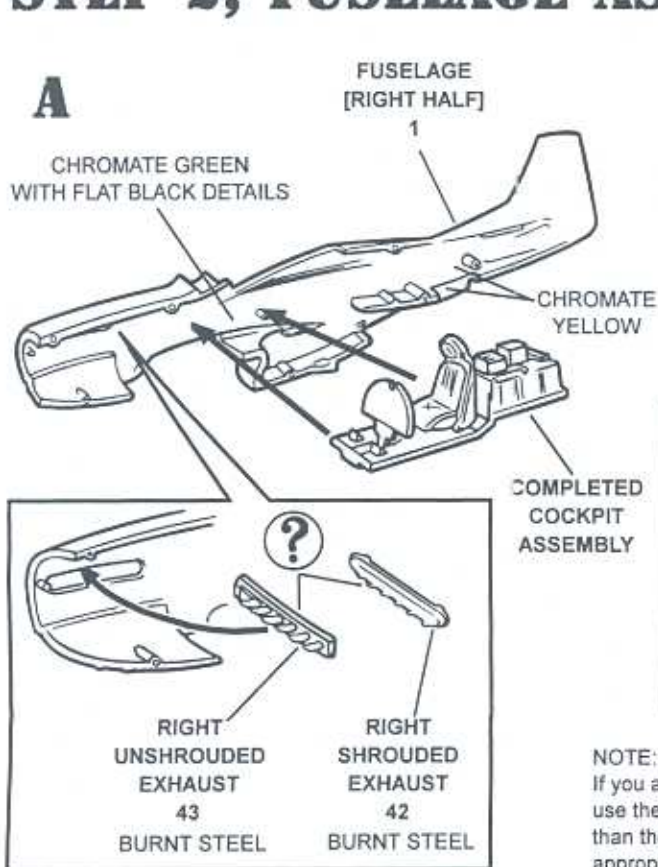

NOTE: Both shrouded and unshrouded exhausts are provided with this kit. If you are using either set of markings included on the decal sheet in this kit, use the unshrouded exhausts, (parts 17 and 43). If you are using decals other than those supplied in this kit, check your references to see which exhaust is appropriate for the P-51D you are modeling.



An example of the unshrouded exhaust is shown here.  
(Detail & Scale photo by Bert Kinzey)



This is what the shrouded exhaust looks like.  
(Detail & Scale photo by Bert Kinzey)

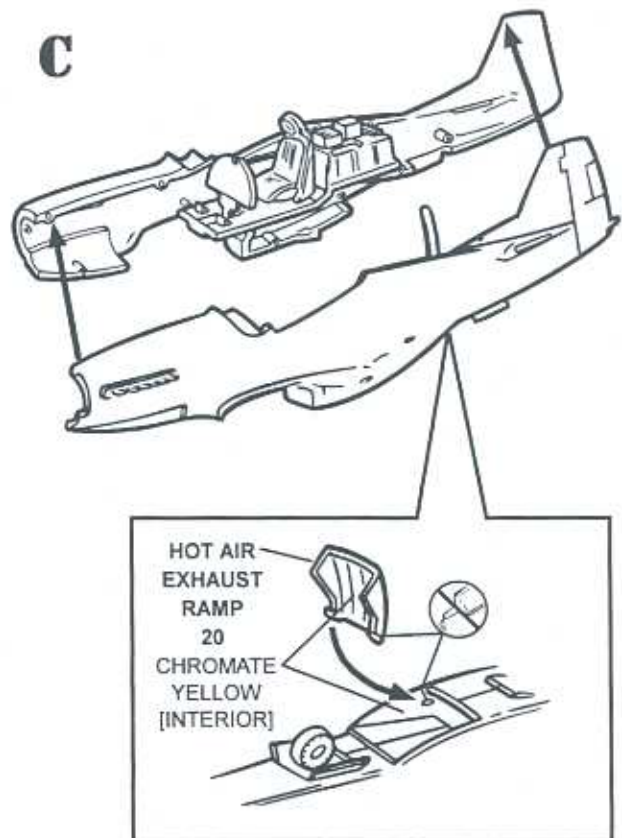

# STEP 3, WING ASSEMBLY

**A** CHROMATE YELLOW [INSIDE SURFACE]  Cut top door off if it is to be displayed in the open position. Place it anywhere on the top of the wing. Glue other two doors in the open position along the leading edge of the gun bay.

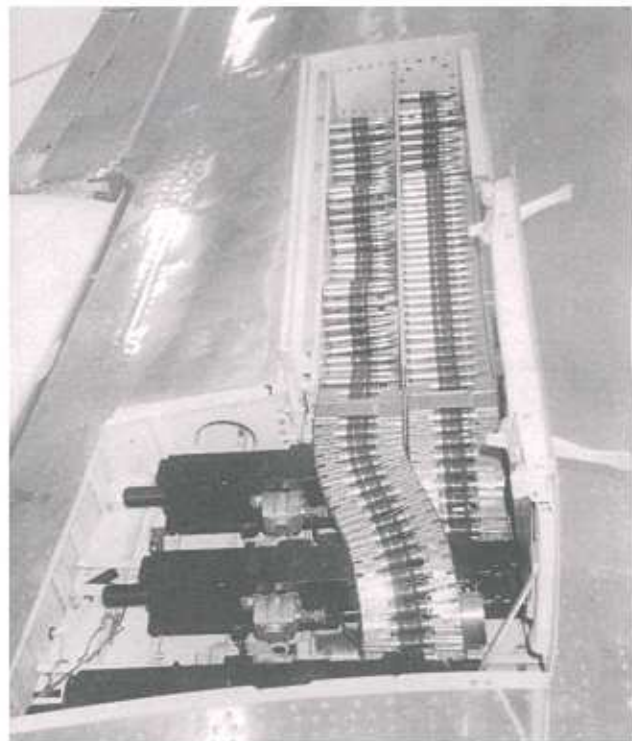
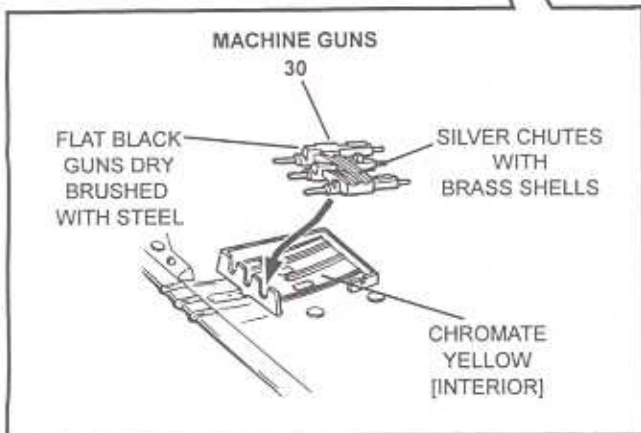
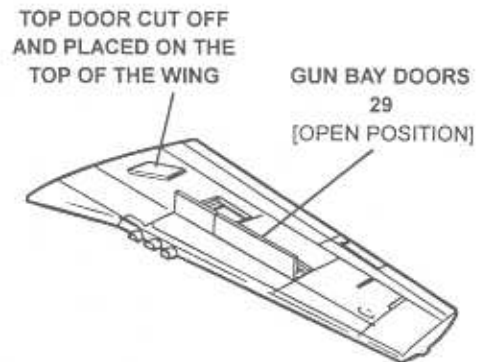
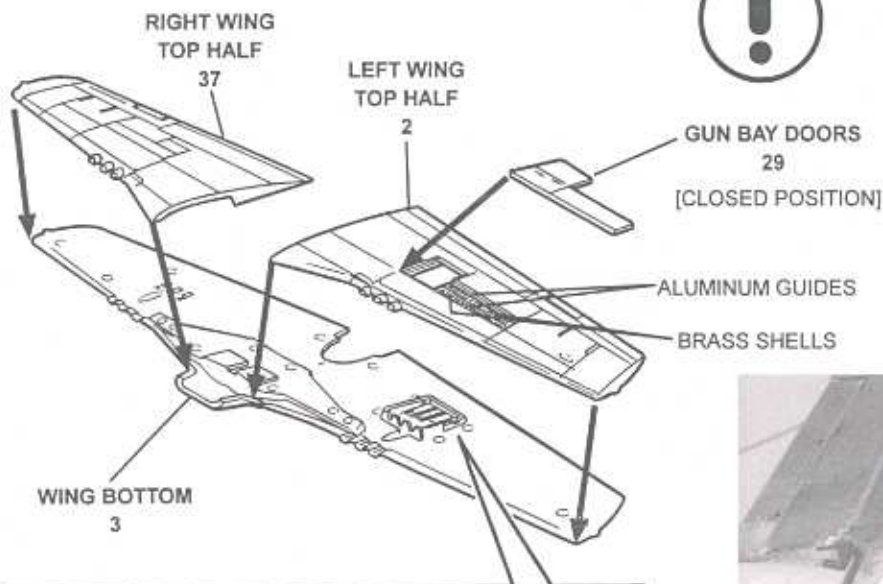

Details of the gun bay in the left wing are visible in this photograph. (Detail & Scale photo by Bert Kinzey)

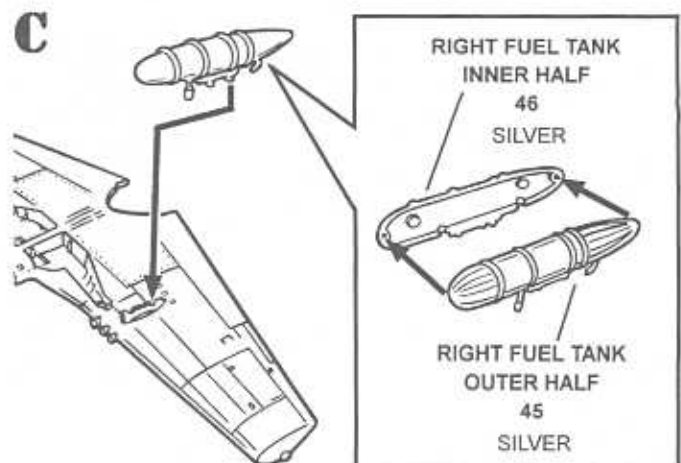
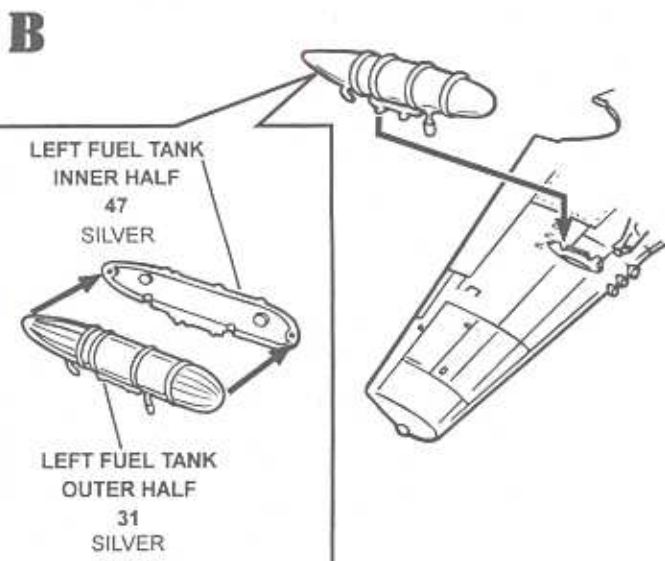

# STEP 4, LANDING GEAR ASSEMBLY

**A**

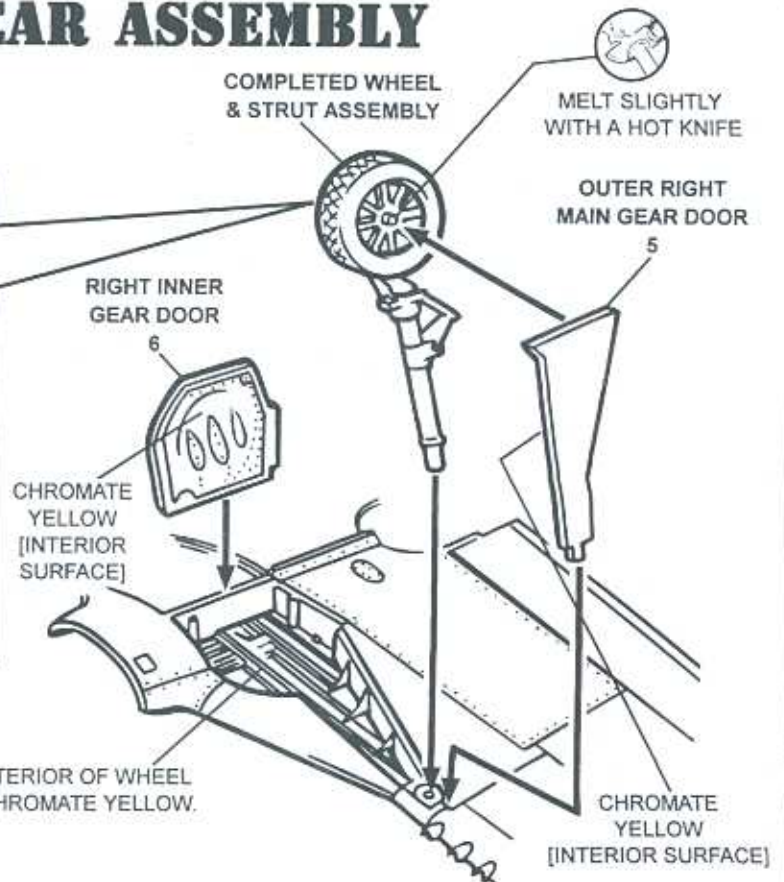
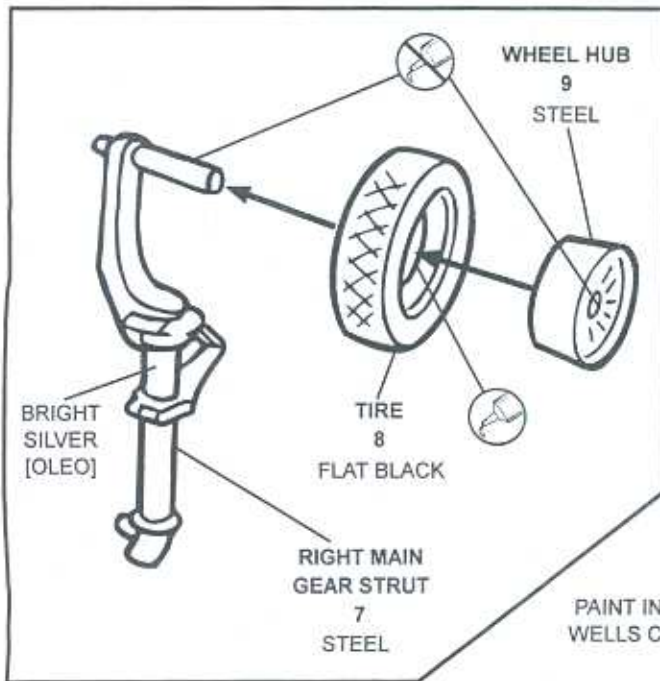

**B**

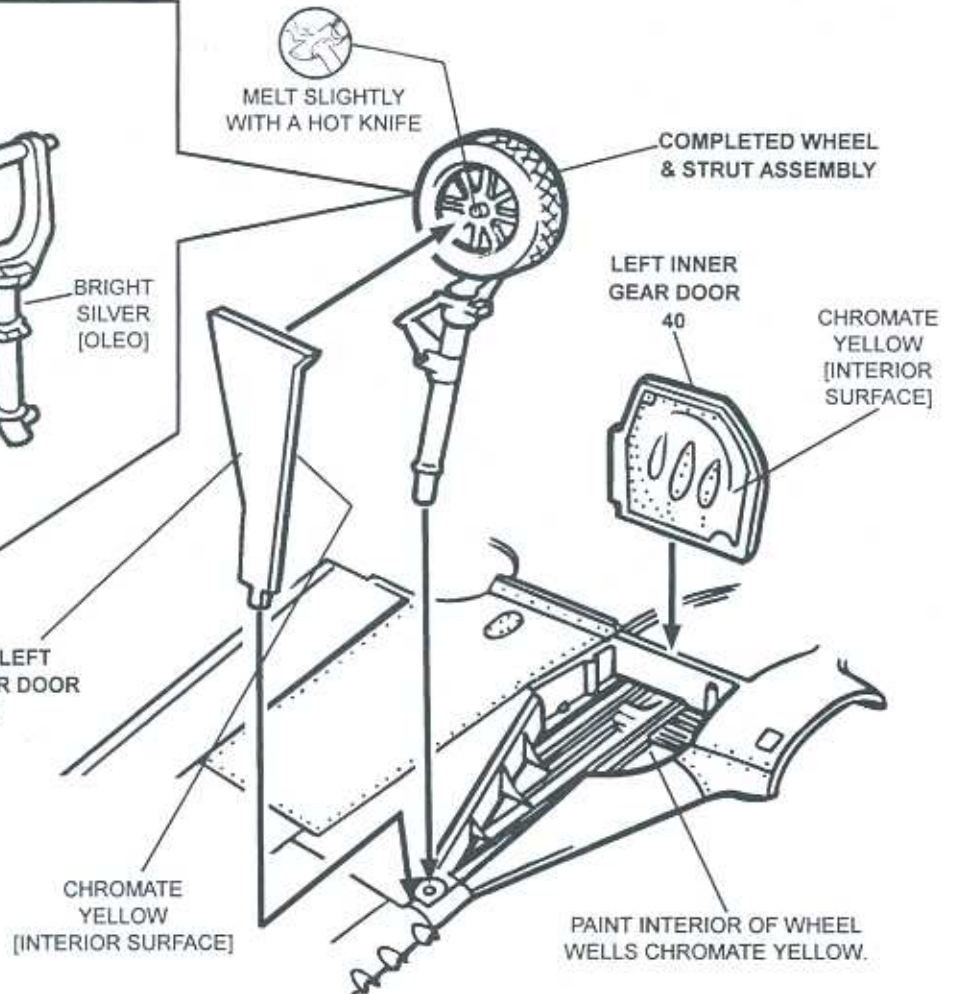
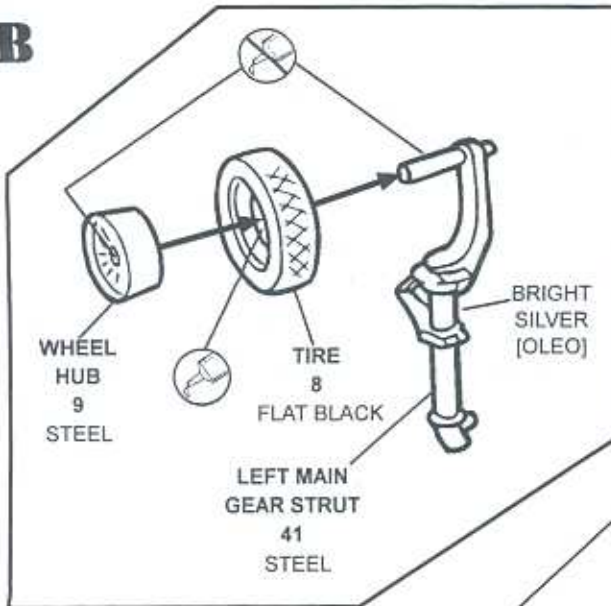

# STEP 5, AIRFRAME ASSEMBLY

LANDING GEAR DETAILS  
OMITTED FOR CLARITY

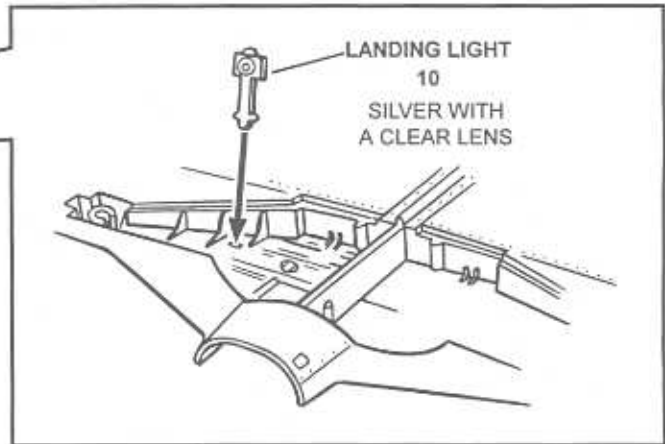
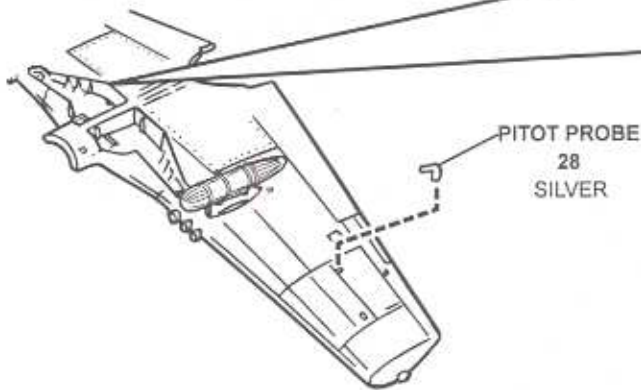

CHROMATE YELLOW  
FRAMEWORK WITH  
SILVER DETAILS

FLAT BLACK

COMPLETED  
FUSELAGE  
ASSEMBLY

CHROMATE  
YELLOW  
[INTERIOR  
SURFACE]

AIR SCOOP  
19

LOWER ENGINE  
COVER  
18

PART CAN BE  
LEFT OFF OR  
GLUED IN PLACE

COMPLETED  
WING ASSEMBLY



Here is the landing light in the left wheel well. Also note the details of the left landing gear.

(Detail & Scale photo by Bill Slatton)



The air intake scoop under the fuselage looks like this when viewed from the front.

(Detail & Scale photo by Bert Kinzey)

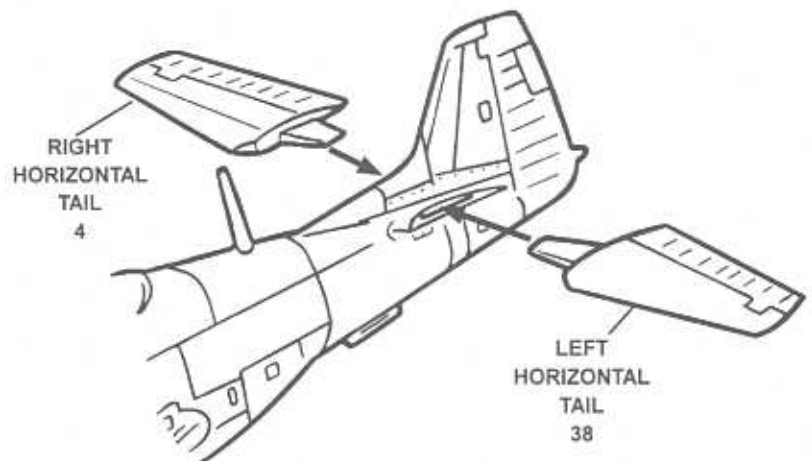

# STEP 6, PROPELLER ASSEMBLY

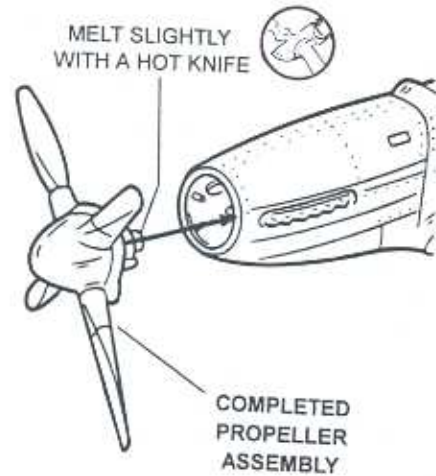
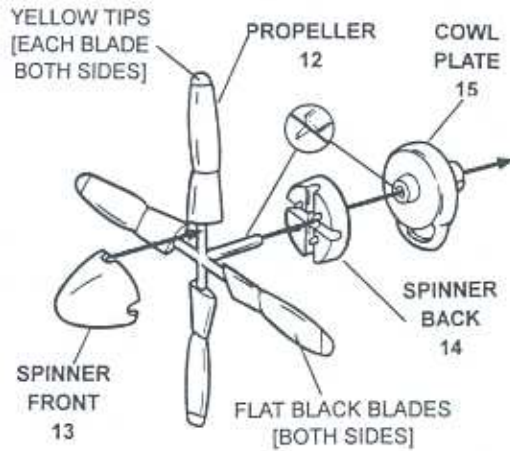

# STEP 7, CANOPY AND PILOT ASSEMBLIES

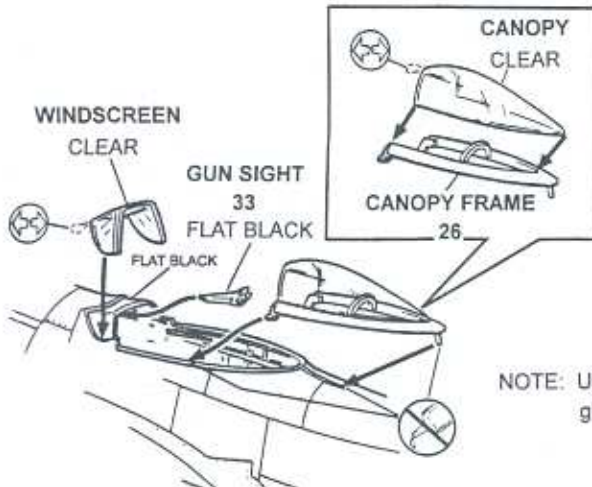

NOTE: See the next page for information about painting the framework on the windscreen and canopy.



## Masks

## P-51 D Basic Stencils

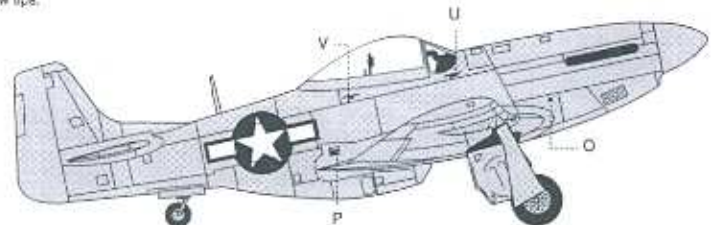
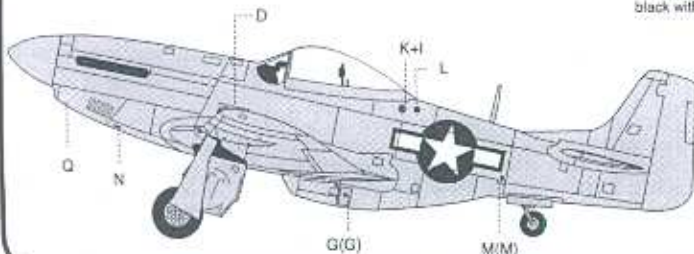
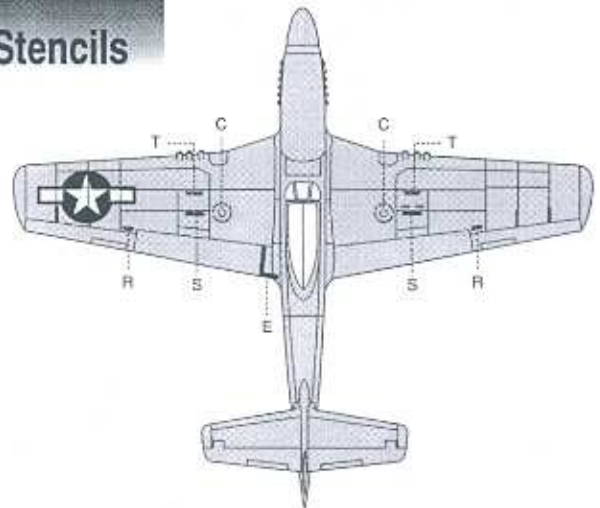
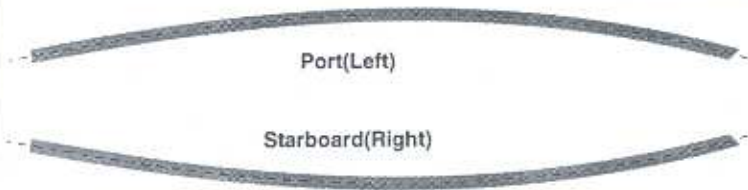



PAINT RED STRIPE ON COWL.  
ON BOTH SIDES OF FUSELAGE

## A/C I

P-51D, "Big Beautiful Doll", 84th FS, 78th FG, Duxford. Flown by Col. John D. Landers. Overall natural metal finish. Olive Drab anti-glare panel with red trim aft of cowl checkers, chin intake is red. Front of spinner 1/2 black, 1/2 white, rear red. Rudder black.

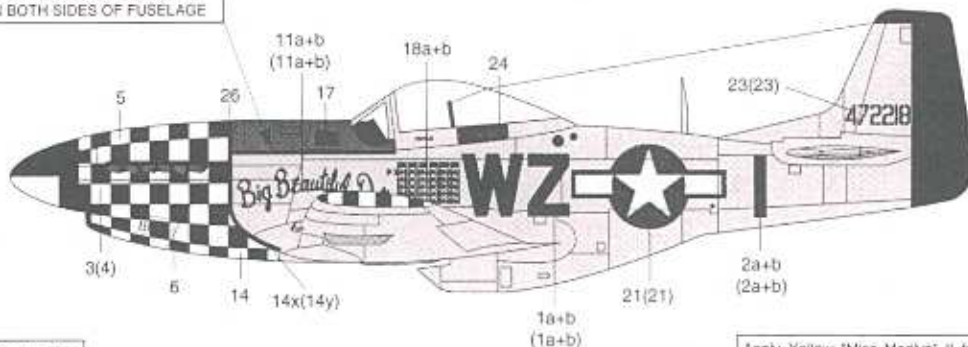

Apply Red "Big Beautiful Doll" first. When dry, apply the Black one on top. Note that the red letters shadow the black ones.

Apply Yellow "Miss Marilyn" if followed by the Green one when dry. Note that Miss Marilyn is shadowed in a different direction from that of "Big Beautiful Doll".

## A/C II

P-51D, "Miss Marilyn II", 343rd FS, 55th FG, Wormingford, Northants, UK. Flown by Robert E. Welch. Overall natural metal finish with black 15" theater stripes on wings. Anti-glare area, rear fuselage, & top of horizontal stabilizers Medium Green 42 with Red trim. Yellow rudder. Green & yellow striped spinner.

*Big Beautiful Doll* *Miss Marilyn II*

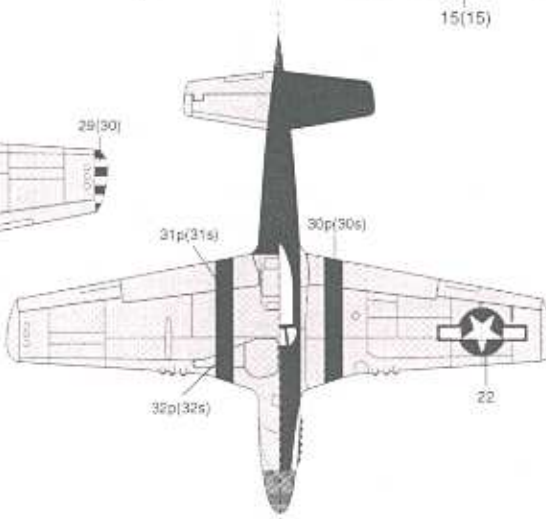
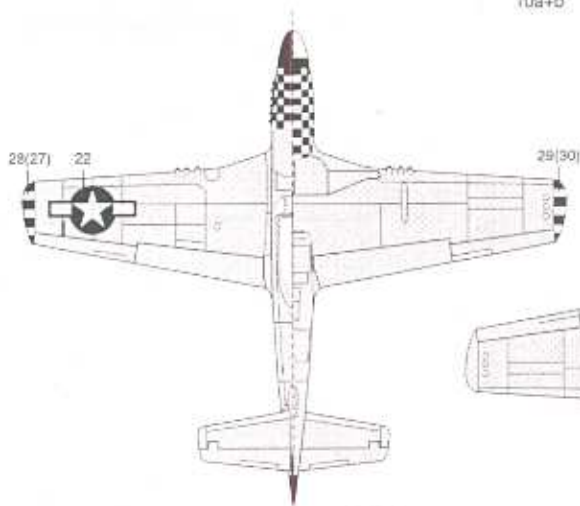
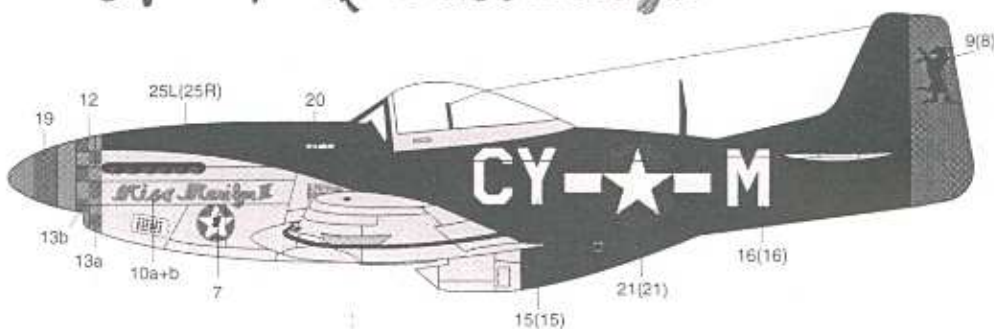

Forward

Hamilton Standard Logo

apply to front side  
of propeller blades

## Note:

Items in parenthesis "()" are to be used on opposite side of the aircraft. Items with a plus "+" are a combination of decals.

## Note:

On decals shown above, you must cut off the clear film on the solid gray areas and slice along the gray dashed lines (approximately two checkers deep).

## References:

1. P-51 Mustang In Action, Squadron Signal Publications.
2. Aces of the Eighth, by Gene B. Stafford & William N. Hess, Squadron Signal Publications, 1973.
3. Markings of the Aces, 8th U.S. Air Force, Book 1, by Theodore R. Bennett, Kookaburra Technical Publications.
3. North American P-51D Mustang in USAAF-USAF Service, No. 1, Aircam Aviation Series, by Richard Ward, Osprey.

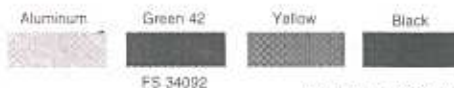

FS 34092

85524100200