

LOCKHEED

SF-71A/B BLACKBIRD

No. 584



HISTORY

The Lockheed SR-71 was developed from the Central Intelligence Agency funded A-12 reconnaissance aircraft program. Basic design concepts for the A-12 were set in 1959 as a follow-on to the U-2 spyplane. The "Article" - as the A-12 was known by insiders - first flew on 26 April 1962 from a then secret test site known as Area 51 - located at Groom Lake, Nevada. By late 1964 a number of all-black CIA A-12's were flying operational, and clandestine, spy missions.

The SR-71, tailored to expanded U.S. Air Force needs, was ordered in December of 1963 and flew for the first time on 22 November 1964 from Palmdale, California. Development and production continued and on 7 January 1966 the Blackbird joined the USAF operational inventory at Beale AFB in California.

The SR-71 carries a wide variety of photographic and electronic sensors. These are widely variable depending upon the reconnaissance requirements for a particular mission. The aircraft uses its high speed and electronic countermeasures to protect itself from hostile action. Although over 900 missiles have been fired at SR-71's, never has one been lost to enemy action.

The SR-71 is operated by the 9th Strategic Reconnaissance Wing of the U.S. Air Force. Aerial refueling, on an international basis, is done by the 100th Air Refueling Wing flying special KC-135Q tankers. Both the 9th and 100th are part of the Fifteenth Air Force (SAC) and based at Beale AFB.

The SR-71 is a true national asset and a remarkable machine: it flies at over 85,000 feet and well over 3 times the speed of sound; the temperature on the windshield at cruise is over 600°F - it is also a design concept over 20 years old! Logic indicates a new, yet secret, reconnaissance aircraft is flying operational missions as a complementary system to the SR-71. Until it is fully revealed, the SR-71 remains the most advanced military aircraft in the world.

SPECIFICATIONS

Power	2 Pratt & Whitney J58 (JT11D-20B)
Weight	Approx. 140,000 pounds
Span	55' 7"
Length	107' 5"
Height	18' 6"
Max. Speed	MACH 3.35
Service Ceiling	92,500'
Max. Unrefueled Range	3,250 miles
Crew	2

Reference Sources

SR-71 Blackbird in Action; Drendel (Squadron/Signal Publications)

Lockheed Horizons - Winter 1981/82; Johnson/Brown (Lockheed Aircraft Corporation)

AeroFax Minigraph I Lockheed SR-71 (A-12/YF-12/D-21); Miller (AeroFax Inc.)

Mach 3+; Goodall (AeroFax Inc.)

BEFORE STARTING

1. Study the illustrations and sequence of assembly before beginning.
2. Decide how much detail you wish to add to your model and whether or not you intend to modify or "convert" the basic model in any way. Study carefully all available reference material before beginning to ensure an authentic model.
3. Always remember, when working with plastic model cement and paint, make sure your work is well-ventilated. The fumes from plastic modeling products can be harmful if inhaled.

PREPARATION OF PARTS

1. Never tear parts off the runners (sprue). Use a Testor Hobby Knife, nail clippers, or small wire cutters.

2. If you desire, you may fill any seams (where parts go together) or imperfections with Testor Contour Putty for Plastic Models which is also available at good hobby shops.

PAINTING

You can obtain an excellent finish on your model using Testor enamels. Detailed descriptions of type of paint and color are included throughout the pages that follow.

Good brushes are essential for proper detailing. **Testor Model Master** brushes are recommended and available at good hobby stores. Be sure you have the entire selection for all your modeling needs. Always keep your brushes clean and soft by cleaning in Testor thinner, washing in soap and water, and storing flat or with bristles up when not in use.

Wash plastic parts before detaching them from the sprue. Warm water and liquid detergent remove the oils left from the manufacturing process. Let the parts dry and avoid excessive handling. Immediately before painting, wipe the parts with a "tac rag" (available at automotive centers) to remove dust and lint.

Most small parts are best painted while still attached to the sprue or they may be detached and held with tweezers or "magic" type transparent tape. Paint in one direction only. If your paint is the correct consistency, brush strokes will disappear as the color dries. If the paint seems too thick, thin it with Testor Paint Thinner. Wheels may be detached from the sprue and fit onto toothpicks or matchsticks for painting. Then just hold the paintbrush against the edge of the wheel and rotate the wheel to obtain a neat clean finish.

Let the paint dry completely before handling. When the parts are dry, assemble the model, following the directions closely. Remember cement will not stick to painted surfaces. Using your Testor Hobby Knife, carefully remove paint from all surfaces to be cemented. After you have assembled your model you may touch up areas where cement has marred the finish.

Some Helpful Words

This plastic model of the SR-71 can produce 4 different versions of the SR-71 plus a CIA A-12. A word of caution: the modification to an A-12 is recommended for the advanced builder only because of the need for the reshaping of plastic parts. However, for those builders less inclined to absolute scale accuracy, the basic SR-71A with A-12 markings makes a striking finished model.

Study the various versions so you can select the airplane you will build. Your choices of SR-71's are: SR-71A, tail number 17974 in the basic SR-71 markings used in the 60's and 70's; SR-71A, number 17974 with mission markings and tail insignia as flown during the Vietnamese war from Kadena Air Base on Okinawa; SR-71B, tail number 17956, is the only raised rear cockpit trainer version of the SR-71 in the world - a one-of-a-kind-airplane; SR-71A, number 17972, is shown in the Low Observable markings applied to the SR-71A in late 1982 and early 1983, and flown from Mildenhall, England.

The dull black paint of the SR-71 is weathered rapidly by the airplane's sustained high speed and aerodynamic heating and buffing. The color tends to go from original black to a very dark gray in a pattern that is controlled by the airframe's substructure. The sheet metal between the substructure gets lighter in color because it gets hotter than the metal attached to the frame. The engraved lines on the model match the substructure, and more substructure is revealed after a "hot flight" with its skin toning. This look can be duplicated by a patient modeller. Be sure to gather research material on the plane. Testor produces all the finishing materials you will want to do the job.

Titanium metal, in its natural state, has a slight orange hue. The CIA A-12, on page 11, shows the proper mix to obtain a near-natural looking titanium tone.

The Decal Use Charts will help you place the proper markings on your selection. Work slowly and carefully.

We recommend the use of Testor paints for finishing. The SR-71 is an overall Flat Black, FS 37038. This is available in **Testor Model Master** spray cans. Another way to obtain the flat finish is paint the model with **Model Master** Gloss Black, FS 17038, spray. Then apply the decals and overspray the decaled model with **Model Master** Clear Flat Finish, No. 1960. Use Testor paints for detailing. Follow the instructions on the assembly.

You will find Historical and Technical notes on various steps as you proceed. These are for the purpose of informing you about significant aspects of the advanced technology incorporated in the SR-71.

Liquid cement, **Testor** #3502, is recommended for construction since it can produce the neatest, quickest, and strongest glue joints. Apply small amounts of cement, using the tip of a **Testor Model Master** #2 brush, to the surfaces to be joined while holding the parts in place. Do not use large amounts of cement.

Tweezers will be useful in assembling the many small parts in this kit. The type used by postage stamp collectors is recommended.

The Testor Corporation would like to thank:

The 9th Strategic Reconnaissance Wing at Beale AFB for giving us the opportunity to photograph the SR-71B; Jim Goodall, whose love and knowledge for and of the SR-71, and willingness to share his collected "goodies" on the bird, made our work easier and often humorous; to the people at the Air Force Museum - Col. Uppstrom and Dave Menard in particular - who gave us a day to measure, sketch, photograph, and drop plumb reference lines on the YF-12A there; Ben Rich who, under tight security restraints, helped where he could; Jay Miller for support and help with D-21 material; Bob Ferguson, at Lockheed, for truly prompt assistance on photography. Thanks are also due to many folks who asked that their names not be used. They know who they are.

1 Parts 7, 8 or 9

Preliminary Painting

- 7, 8, 9 interior walls:
FS 36231 Dark Gull Gray
7, 8, 9 canopy rail areas:
No. 1780 Steel

Assembly

1. If you are building an SR-71A or A-12, glue 8 to 7.
2. If you are building an SR-71B, glue 9 to 7.

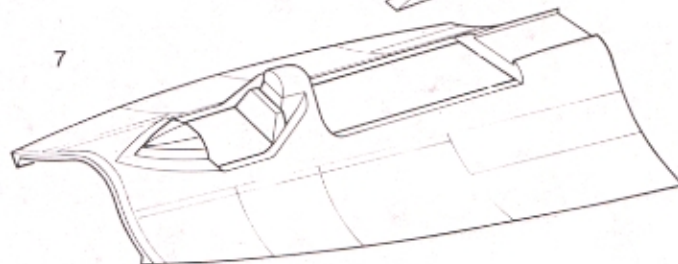
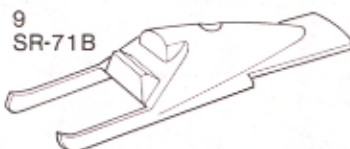

2 Parts 7, 10, 11, 12, 13, 14 or 15

Preliminary Painting

10, 11, 12, 13:

FS 36231 Dark Gull Gray

12, 10 raised instrument areas:

FS 37038 Flat Black

12, raised radar screen faces:

FS 34227 Pale Green

14, 15 outside surfaces but not top:

FS 17178 Chrome Silver

Assembly

1. If building an SR-71A, glue 14 into place. If building an SR-71B, glue 15 into place.
2. Glue cockpit back walls, 11, and 13, into place. Now glue instrument panels, 10 and 12, into position. Note that 12 goes all the way up into the head fairing area.

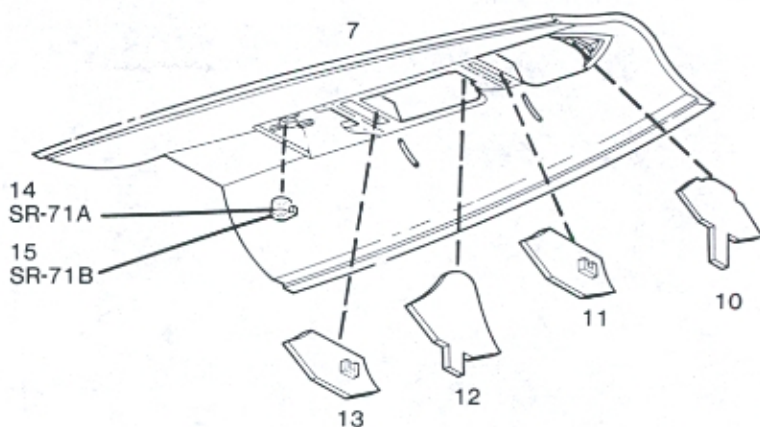

3 Parts 1, 2, 3, 4, 5 and 6

Preliminary Painting

1, 6, sides and back of 3 and 4:

FS 36231 Dark Gull Gray

2, 5:

FS 37038 Flat Black

5, stripes:

FS 13538 Chrome Yellow

3, 4, seat and back cushions:

FS 34227 Pale Green

3, 4, headrest portion at top:

No. 1104 Gloss Red

Assembly

1. If you are building an SR-71B, glue riser block, 6, into place. Discard 6 if building SR-71A.
2. Glue seat halves, 3 and 4 together. Now glue ejection actuating rings, 5, to the seats. Glue the control sticks 2, into place. If building an SR-71A discard the rear stick. You can now glue the seats to the cockpit floor, 1.

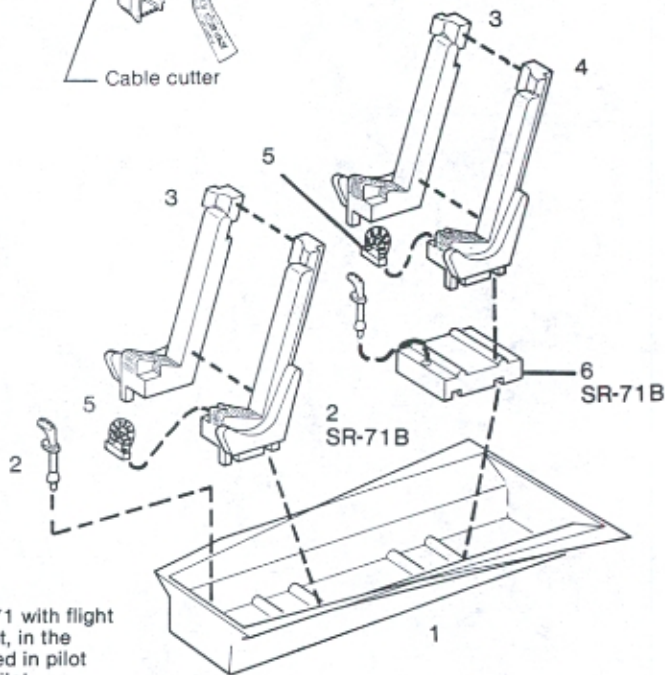
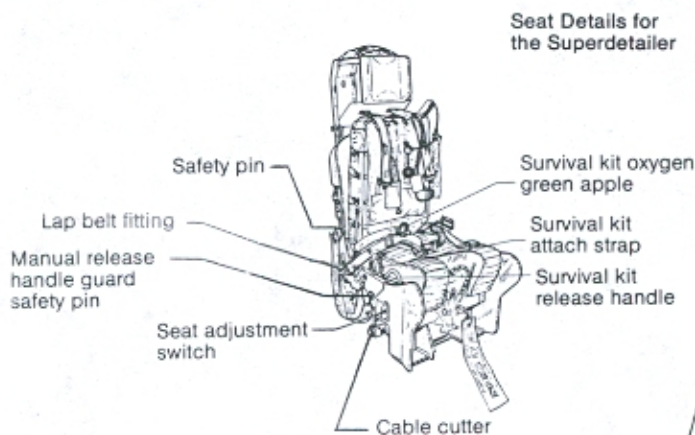

HISTORICAL NOTE

The SR-71B is the only SR-71 with flight controls, other than autopilot, in the back seat. The aircraft is used in pilot selection and initial SR-71 pilot familiarization and training.

4 Parts 20, 1, 7

Preliminary Painting - none

Assembly

1. Glue cockpit box, 1, to the locator notches of lower fuselage chine, 20.
2. Glue cockpit area upper chine, 7, to the lower chine. (The drawing shows upper components for an SR-71A).

HISTORICAL NOTE

Cockpit details of the SR-71 are highly classified and were off-limits when this kit was researched. Equipment controls constantly change and certain systems aboard are Top Secret. Because of official secrecy, the cockpits in this kit could not be made totally accurate.

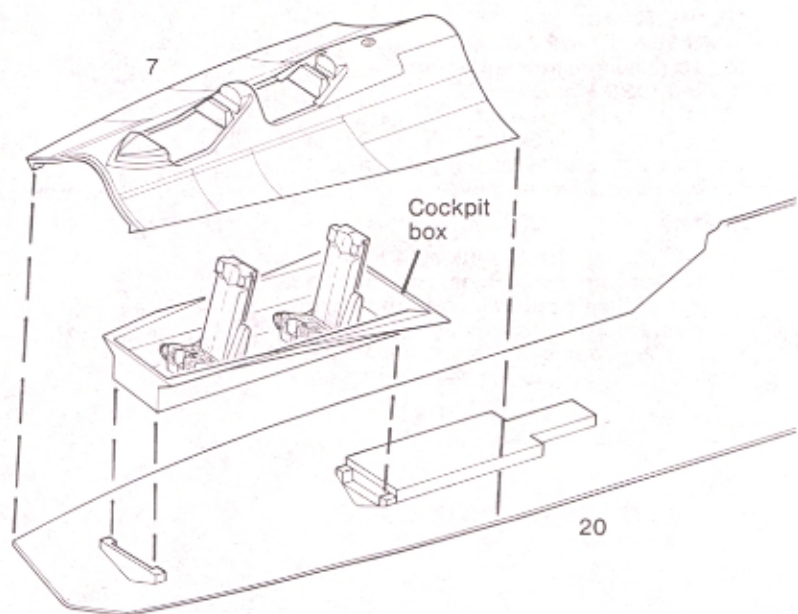

5 Parts 20, 23, 24, 63, 65 and 66

Preliminary Painting - none

Assembly

1. Glue camera windows, 23, to 20.
2. Glue the upper fuselage and refueling socket, 24, to 20.
3. Glue panoramic camera window, 63, to nose forward lower chine, 64. Now glue nose upper section, 65, to 64.
4. Glue pitot tube, 66, to nose, 64 and 65.
5. Glue nose, 64 and 65, to cockpit section.

TECHNICAL NOTE

The nose of the SR-71, forward of the cockpit, can be changed. It is thought 7 different types of recon noses can be attached. The rear equipment bays are also very changeable. Cameras and film are heated before installing them in the airplane in order to stabilize all dimensions and thermal effects.

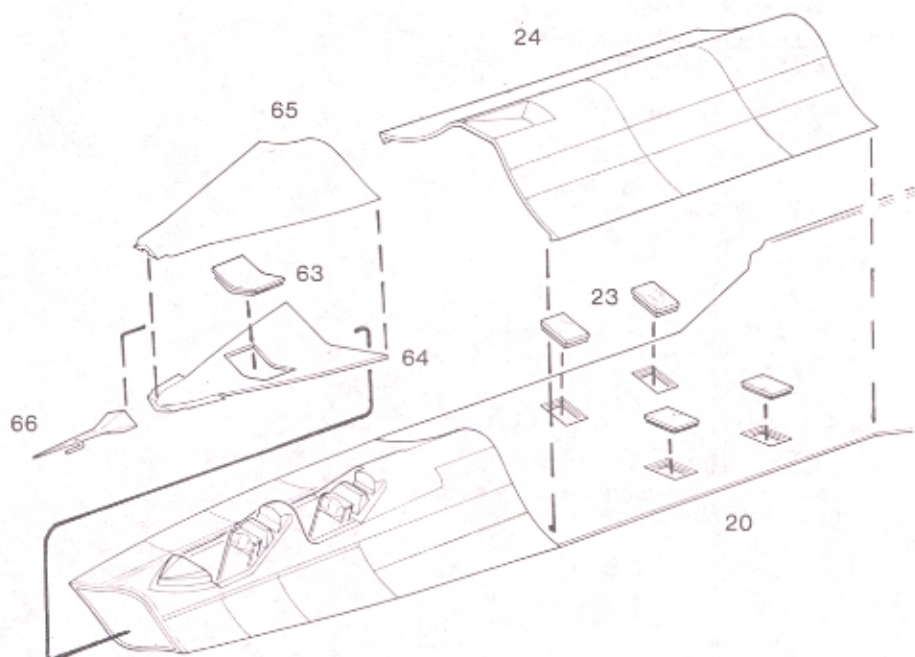

6 Parts 16, 17, 18, 19, 20, 21 and 22

Preliminary Painting

16, 17 landing gear well sidewalls of 18 and 20:

Titanium - mix 18 drops of Testor No. 1127 **Orange** in 1/4 oz. bottle of Testor No. 1146 **Chrome Silver**.

Assembly

1. Glue 16 and 17, to aft lower fuselage, 18
2. Glue 18, to wing upper center section, 19. Now glue forward fuselage, 20, into place. Clamp with wooden clothespins as shown.
3. Glue upper boattail, 22, into place. Next glue lower boattail, 21, into position. Set aside to dry.

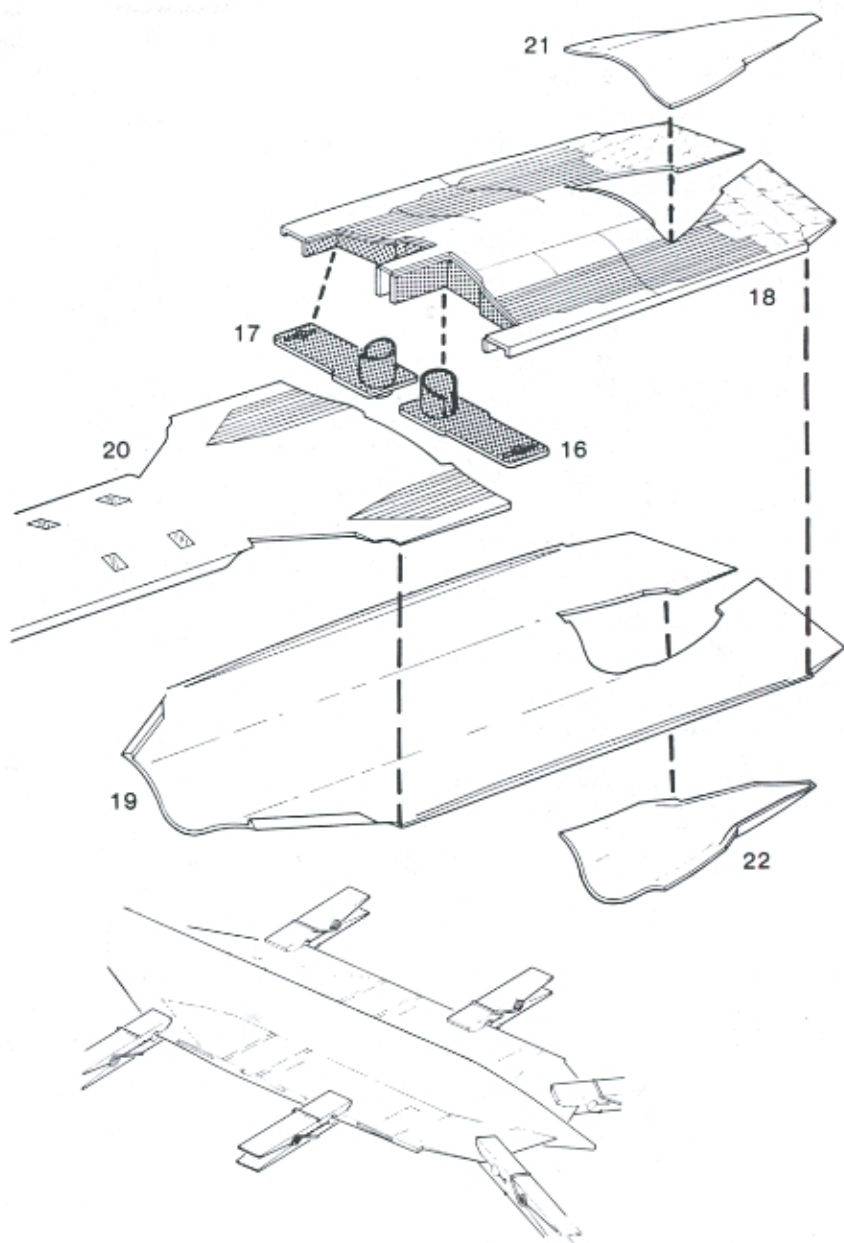

7 Parts 25 through 31, 33, 34, 38

Preliminary Painting

28 outer surface:

Titanium mix, see Step 6

29, 30, 31 inside surface:

FS 36495 Light Gray with **FS 37038 Flat Black** streaking

Assembly

1. Glue upper and lower left nacelle halves, 25 and 26, together.
2. Glue fin outer surface, 33, to rudder and fin, 34, and glue to nacelle top.
3. If you are building an SR-71B, glue filler block, 38, into place on burner annular section, 29, exactly as shown. Then glue to back of nacelle.
4. If building SR-71A or A-12, glue, 29, to back of nacelle. Discard part 38.
5. Glue, 30 to 31, and then glue to 29.
6. Glue inlet spike forebody, 27, to inlet spike bleed, 28. Then glue spike unit into nacelle front butting against the wall inside the upper nacelle half.

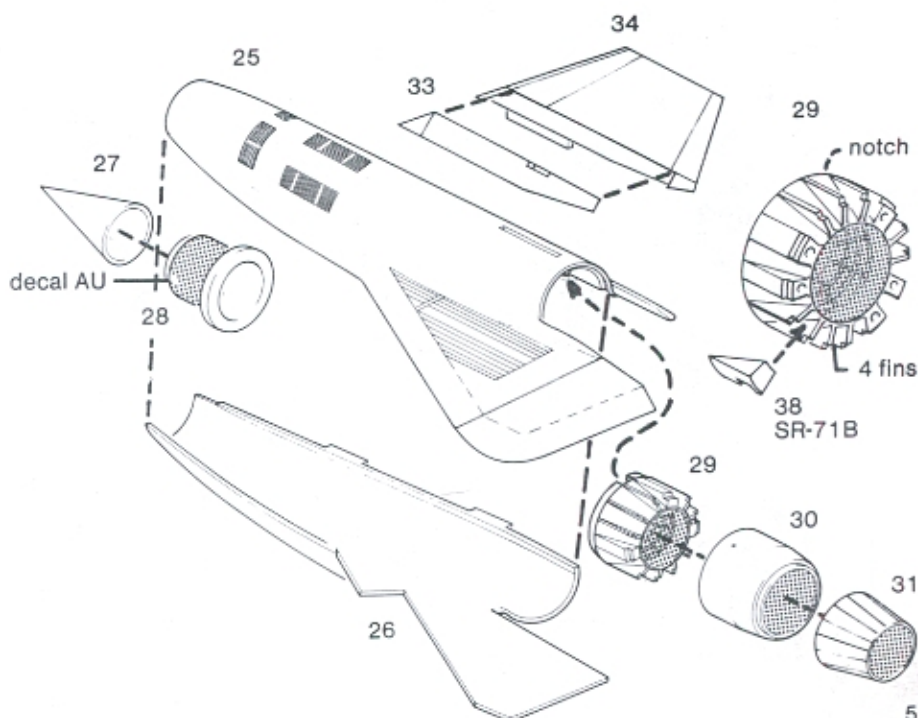

8

Parts 27, 28, 30-32, 35-37, 39, 40

Preliminary Painting

28 outer surface:

Titanium mix, see Step 6

30, 31, 37 inside surface:

FS 36495 Light Gray with

FS 37038 Flat Black streaking

Assembly

1. Glue upper and lower right nacelle halves, 35 and 36, together.
2. Glue fin outer surface, 39, to rudder and fin, 40, and glue to nacelle top.
3. If you are building an SR-71B, glue filler block, 32, into place on burner annular section, 37, exactly as shown. Then glue to back of nacelle.
4. If building SR-71A or A-12, glue, 37, to back of nacelle. Discard part 32.
5. Glue, 30 to 31, and then glue to 37.
6. Glue inlet spike forebody, 27, to inlet spike bleed, 28. Then glue spike unit into nacelle front butting against the wall inside the upper nacelle half.

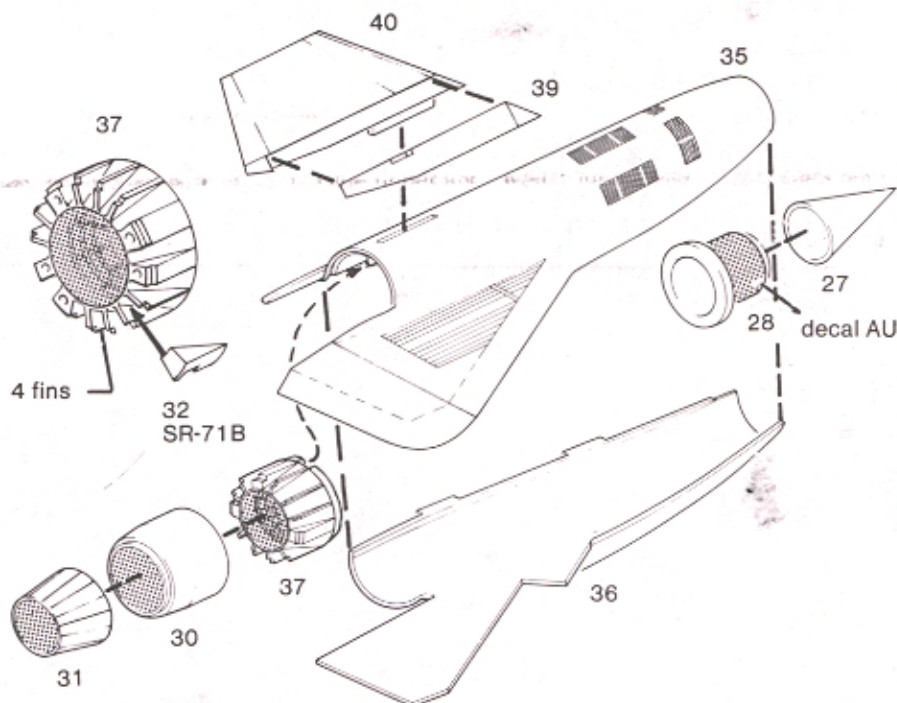

TECHNICAL NOTE

The engine nacelles are the key to the SR-71 performance. At cruise speed there is more pulling force created by the inlet than there is pushing force created by the engine. The airplane, literally, sucks it way through the air.

TECHNICAL NOTE

The numerous grille-like areas and doors on the SR-71 inlet help control bleed air flows in and out of the nacelle. The principal concern is to maintain proper positioning of the inlet spike shockwave so that airflow in the duct is not choked off.

9

Parts; Center Section, Right Wing and Nacelle, Left Wing and Nacelle

Preliminary Painting - none

Assembly

1. Glue right outer panel to center section.
2. Glue left outer panel to center section.
3. Watch alignment carefully. When viewed from the rear the wing panels should be straight out - no drooping, not angled upward. Set aside to dry. Overnight is wise.

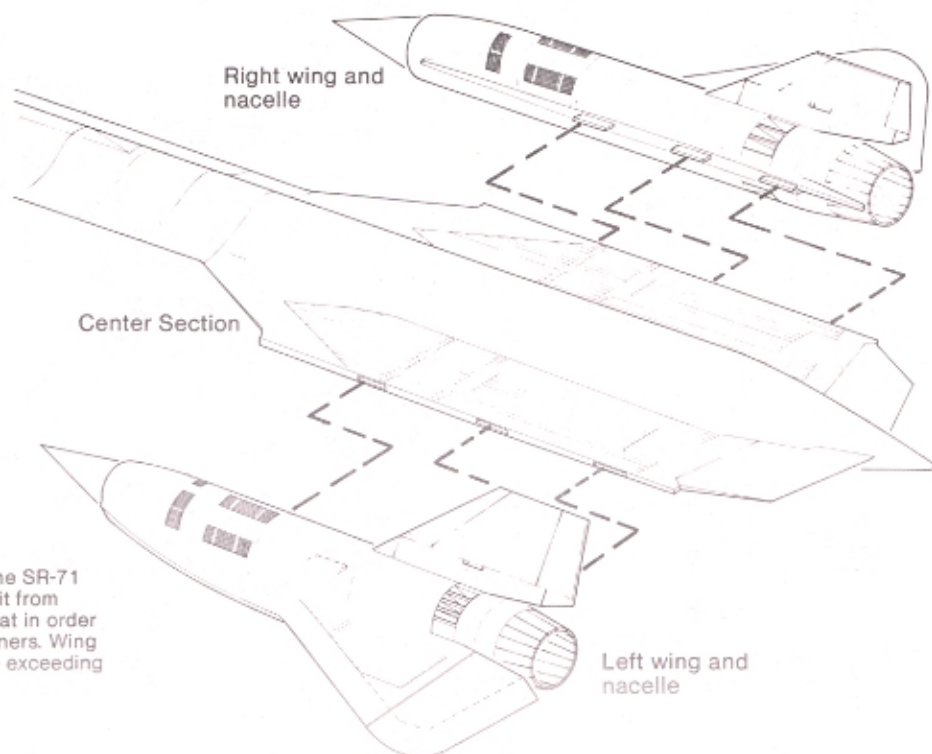

TECHNICAL NOTE

Corrugations are placed in the SR-71 wing sheet metal to prevent it from curling at high speed and heat in order to prevent popping the fasteners. Wing surfaces have a temperature exceeding 525°F at cruise airspeed.

10

Parts 67, 68, 69, 70 and 71 -
SR-71A

Preliminary Painting

71, 71:

No. 1146 **Chrome Silver**

67, 68, 69 inside surfaces but not window areas:

FS 36231 Dark Gull Gray

67, 68, 69 outside but not windows:

FS 37038 Flat Black

Assembly

1. Glue windshield, 68, to the fuselage.
2. Canopies can be glued in place either opened or closed. If closed, discard lift cylinders, 70, and 71, and glue 67 and 69 into place.
3. If canopies are to be opened cement, 70 and 71, into notches on backwalls and to steps inside canopies. Glue canopies to fuselage at rear.

TECHNICAL NOTE

At design cruise airspeed outside air striking the windshield heats it to 622°F.

SR-71A

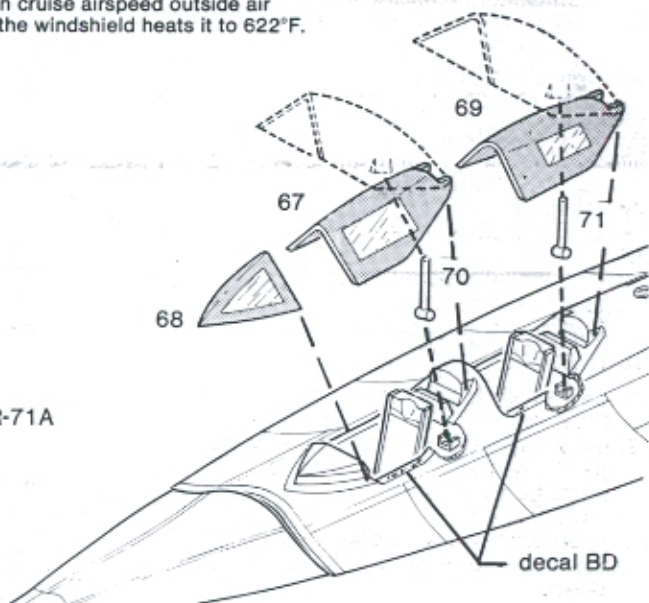

TECHNICAL NOTE

Air temperatures around the cockpit average about 500°F at cruise speed. Though the interior is air-conditioned, the various cockpit controls and switches get hot enough to burn an ungloved hand. Food can be warmed by merely holding it against the inside canopy glass.

HISTORICAL NOTE

17956 is the only SR-71B in the world. there were 2, but 17957 crashed at Beale AFB on January 12, 1968.

11

Parts 67, 68, 70, 72 and 73 -
SR-71B

Preliminary Painting

70, 73:

No. 1146 **Chrome Silver**

67, 68, 72 inside surfaces but not windows:

FS 36231 Dark Gull Gray

67, 68, 72 outside but not windows:

FS 37038 Flat Black

Assembly

1. Glue windshield, 68, to the fuselage.
2. Canopies can be glued in place either opened or closed. If closed, discard lift cylinders, 70, and 73, and glue 67 and 72 into place.
3. If canopies are to be opened cement, 70, and 73, into notches on backwalls and to steps inside canopies. Glue canopies to fuselage at rear.

SR-71B

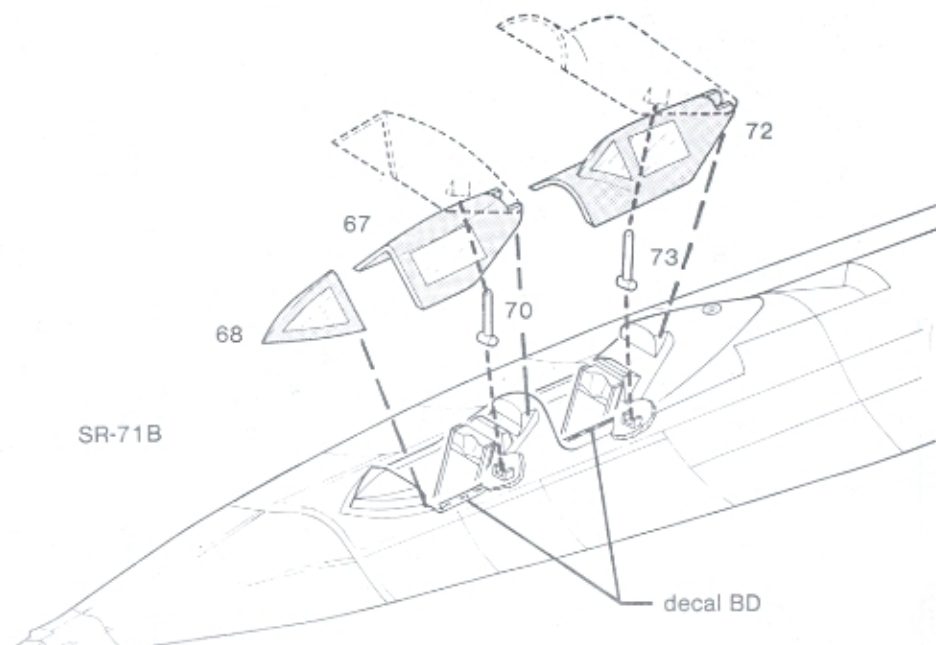

12

Parts 41, 58, 59, 60, 61 and 62

Note: If model is to be built with doors closed, glue retraction strut cover door, 60, and nosewheel well doors, 62, to fuselage.

Preliminary Painting

- 58:**
No. 1180 Steel
- 61/41 tires:**
No. 1183 Rubber
- 61/41 hubs:**
No. 1147 Gloss Black
- 59:**
No. 1146 Chrome Silver
- 60, 62** inside of doors:
Titanium mix - see Step 6

Assembly

1. Cement light, 59, to nose gear strut, 58. Glue strut into sockets in fuselage.
2. Glue wheel halves, 41 and 61, together, paint, and glue to strut axles. Glue retraction strut cover door, 60, to nose strut.
3. Glue nose gear well doors, 62, into place. The doors should hang straight down.

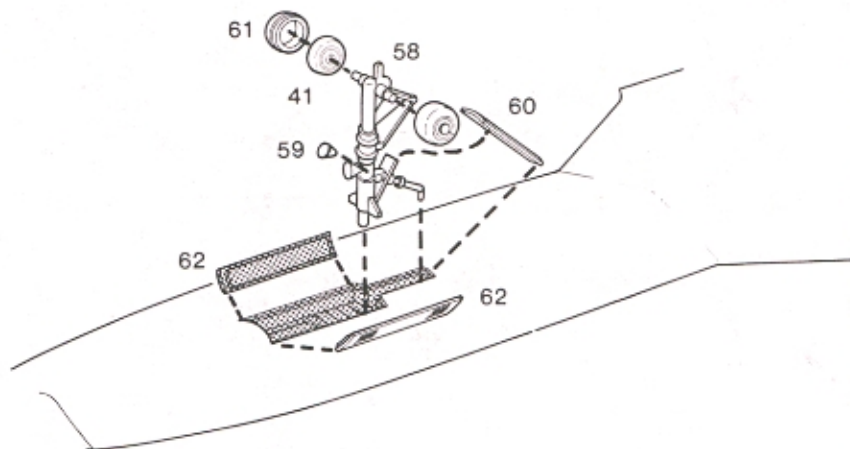

TECHNICAL NOTE

The special tires contain many layers of fabric and are rated at 22 ply. Aluminum particles are contained in the rubber to help solve heat problems. The main wheels retract into an explosion shield so that if a tire overheats and blows out it won't scatter rubber and rip up the delicate hydraulic lines inside the wheel well. All tires are filled with nitrogen rather than air. Inflation pressures are near 300 psi.

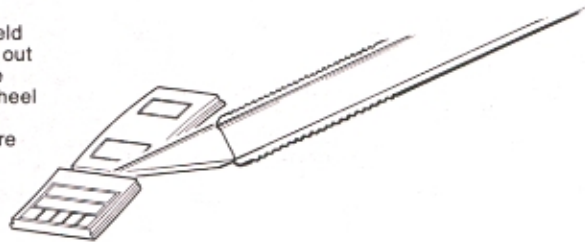

13

Parts 41 through 57

Note: If model is to be built with doors closed, glue main gear cover door units 47/49 and 54/56 over well without cutting apart.

Preliminary Painting

- 43, 44, 52, 53:**
No. 1180 Steel
- 46:**
No. 1146 Chrome Silver
- 48, 55** insides of **47, 49, 50, 51, 54, 56:**
Titanium mix - see Step 6
- 41/42, 41/45** hubs:
No. 1185 Rust
tires:
mix of No. 1146 Chrome Silver and No. 1138 Gray.

Assembly

1. Glue wheel halves, 41 and 42, together. Now glue main gear struts, 43/44 and 52/53, around wheels. Build four sets of wheels, 41/45, and glue to outside strut wheel axles. Cement struts into wheel wells.
2. Glue retraction cylinders, 46, to struts. Glue door links, 48 and 55, to struts.
3. Glue door actuators, 50 and 51, to wheel cover doors, 49 and 56. Glue doors in place.
4. Glue main strut doors, 47 and 54, in place. See helpful photos on back page.
5. If you are building the SR-71B, glue the ventral fins, 57, to the nacelles.

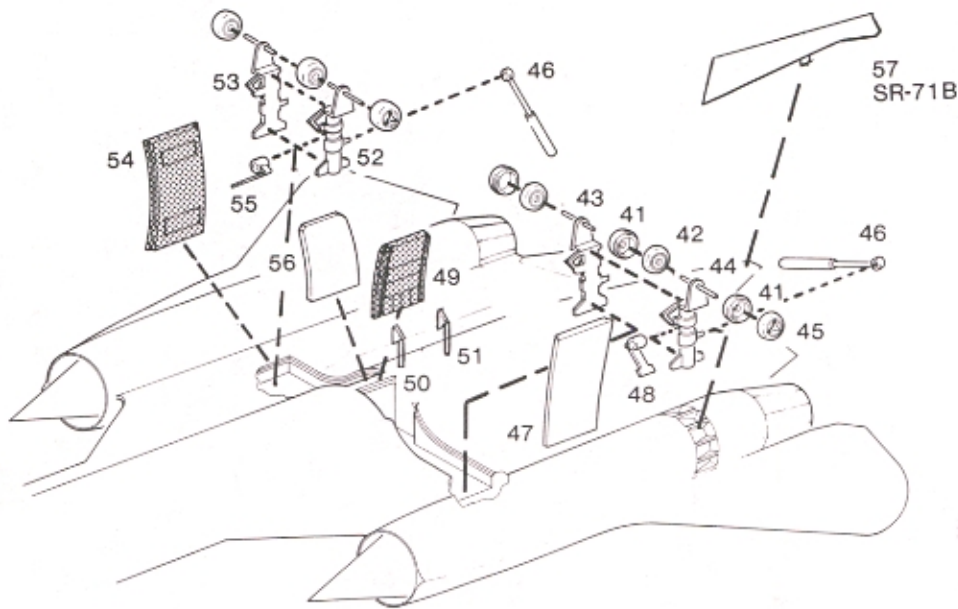

APPLYING DECALS

1. Decals adhere best to a smooth and shiny surface. If you have finished your model in a flat finish mask the clear areas - canopy glass, camera windows - and spray entire model with **Testor Glosscote** #1261. Let dry thoroughly.
2. Use the Decal Use Charts on page 9 or 12 and cut out the decals you will use.
3. Work with one decal at a time, dip in clear water for no more than 5 seconds, remove, place on dry paper towel for 1 minute.

4. When decal slides easily on backing paper, slide it onto surface of the model with soft paintbrush - the **Testor Model Master #2** is perfect for this. Remember: decals are thin and can be ripped. Work slowly and patiently.
5. Apply a small amount of **Testor Decal Set #8804** to each decal. Allow the decal to dry undisturbed.
6. When the decals are completely dry (usually overnight), apply a coat of **Testor Dullcote #1260** to the entire model. This will give an authentic dull finish and protect the decals. Remove masking from canopy and camera windows.

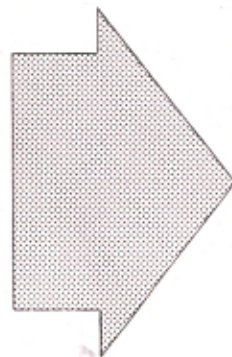

SR-71/B
Overall finish **FS 37038**
Flat Black

Paint titanium mix
from Step 6

DECAL USE CHARTS

Each decal element on the decal sheet has a letter key to identify it: A, AY, BH, for example. The following decal use charts show what decals are used on the various model choices.

- 1. Elements used on all SR-71 models:**
AA, AB, AC, AD, AE, AF, AU, AV, AY, AZ, BA, BB, BD, BE, BF, BM through BU.
- 2. SR-71A, tail number 17974:**
Elements in 1 plus CL, CR (see note on side views), E, G, H, J, L, N, O, S, T, U, V, W, X, Y, Z, AH, AK, AN, AR, AS, AW, AX, BH, BJ, BL.

- 3. SR-71A, 17974, Kadena-based:**
Elements in 1 and 2 above plus D, AJ.
- 4. Low Observable SR-71A, 17972; 1983:**
Elements in 1 above plus A, B, O, R, T, U, V, W, X, Y, Z, AG, AL, AP, AQ, AT, BI, BK.
- 5. SR-71B, 17956, standard markings:**
Elements in 1 above plus E, F, I, J, L, N, Q, S, T, U, V, W, X, Y, Z, AH, AK, AO, AR, AS, AW, AX, BC, BG, BJ, BL.

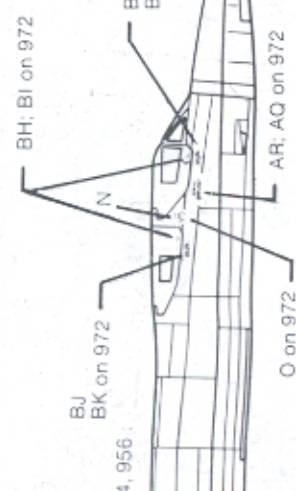
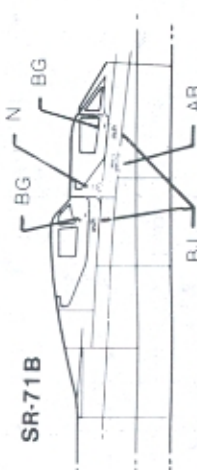
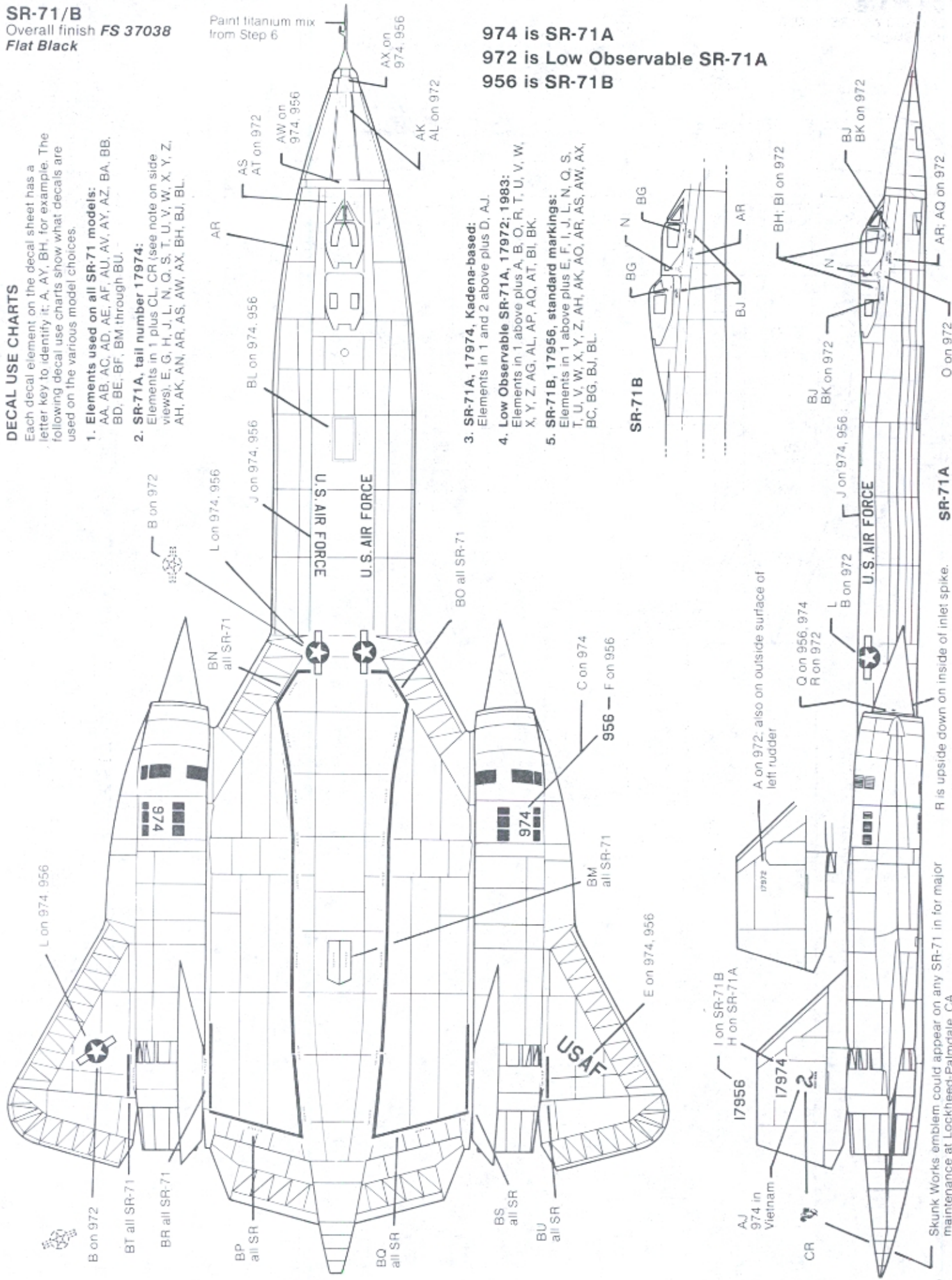

Skunk Works emblem could appear on any SR-71 in for major maintenance at Lockheed-Palmdate, CA.

R is upside down on inside of inlet spike.

A on 972, also on outside surface of left rudder

Q on 956, 974
R on 972

L on 974, 956
B on 972

SR-71A

SR-71B

Q on 972
AR, AQ on 972

BO all SR-71

C on 974
956 — F on 956

BM all SR-71

E on 974, 956

BU all SR

BS all SR

BC all SR

BP all SR

BR all SR-71

BT all SR-71

B on 972

L on 974, 956

B on 972

BN all SR-71

J on 974, 956

BL on 974, 956

AR

AS
AT on 972

AW on 974, 956

AX on 974, 956

AK
AL on 972

I on SR-71B
H on SR-71A

17956

17974

2

AJ 974 in Vietnam

CR

CIA A-12/M-12
Conversion for expert
builders only

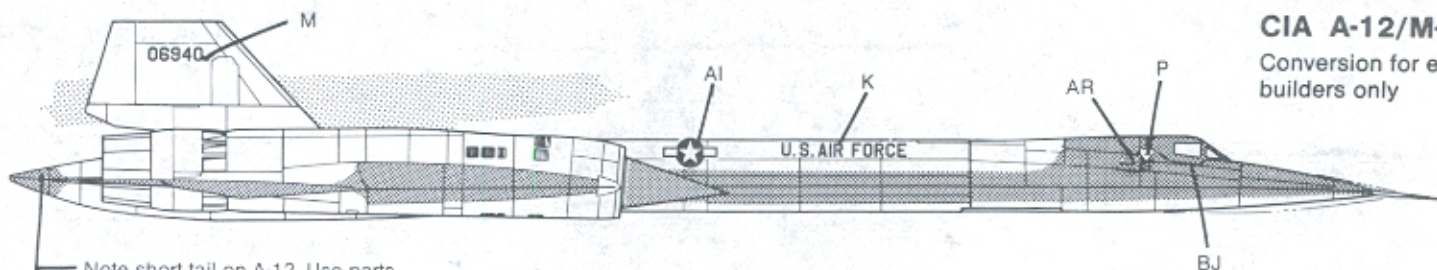

Note short tail on A-12. Use parts from **Testor YF-12** (Kit No. 588) or carve from wood or plastic.

DECAL USE CHART

6. CIA A-12/M-12, 06940:
Use only the following decal elements; K, M, P, AI, AM, AR, BC, BD, BJ.

PAINTING

 FS 37038 *Flat Black*

 *Titanium*

Mix 18 drops of **Testor No. 1127 Orange** in 1/4 oz. bottle of **Testor No. 1146 Chrome Silver**

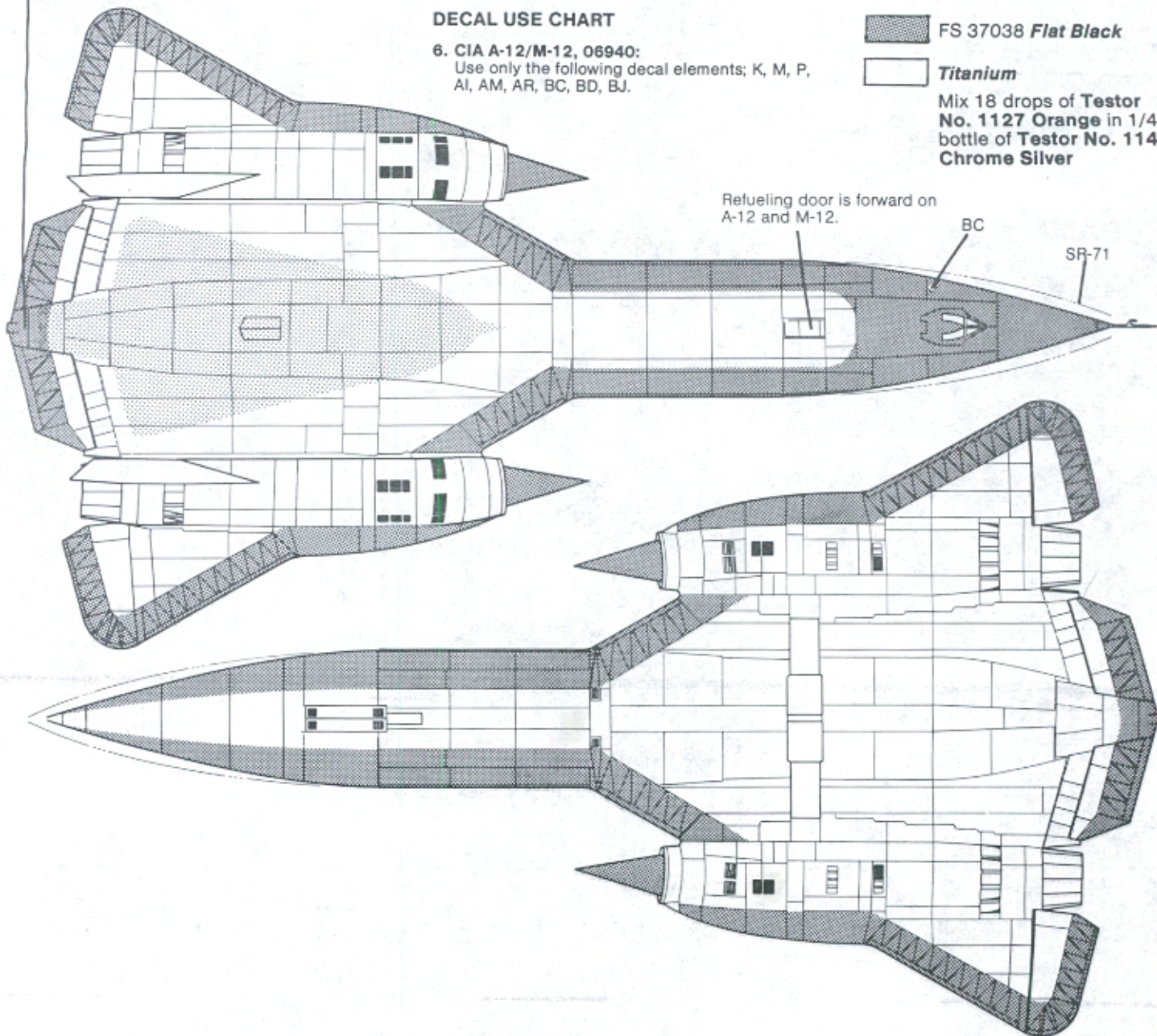

Refueling door is forward on A-12 and M-12.

No second seat or window on A-12 but there is window on M-12 (drone carrier).

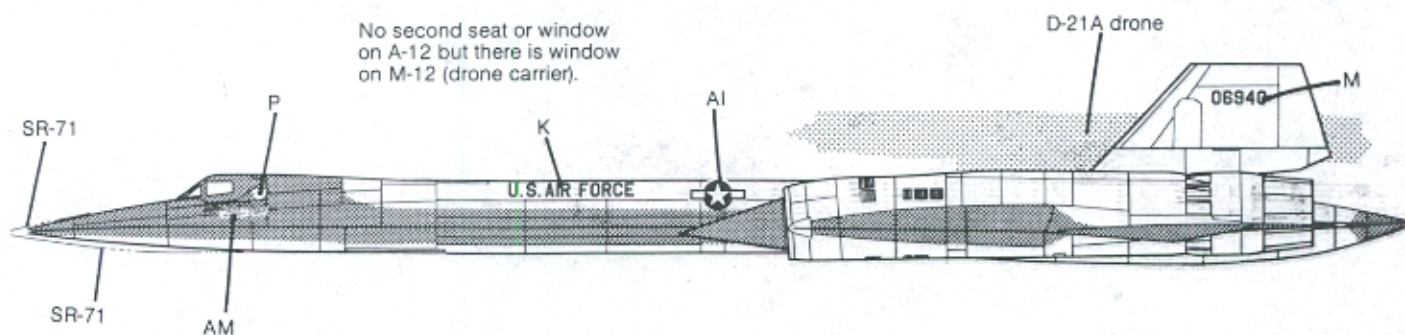

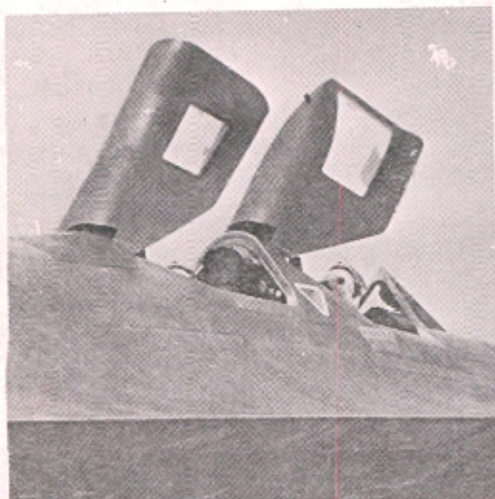

SR-71 taxiing. Bump on pilot's canopy is a retractable periscope. Note scopes in rear crew station and RCS's head way down in cockpit.



Pilot's station of SR-71A. Note seat, canopy lift cylinder. Note scuffed paint on cockpit sill edge.

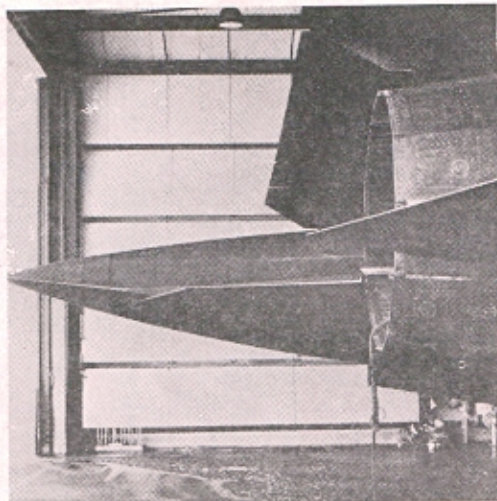

Boattail and nacelle outlet "feathers". Circled chalk marks are maintenance crew inspection marks made after a flight.

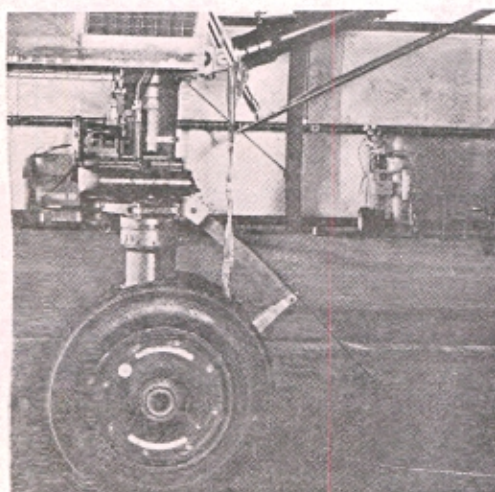

Left side of nose gear. Wheel hub is black as is retraction strut cylinder.

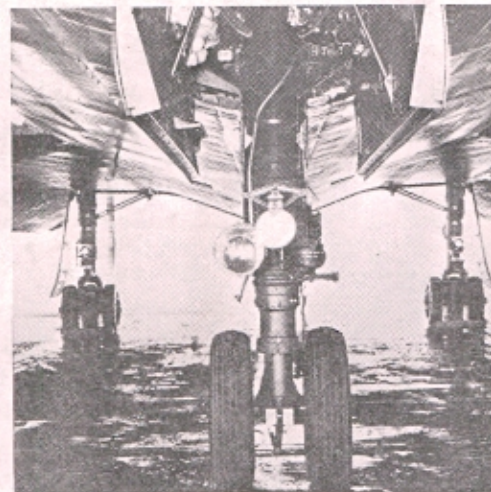

Front of nose gear. Note double landing light. Photo shows angles of various doors in normal ground position.



Outside surface of left fin and rudder. This is 17974 after major overhaul and repaint at Lockheed-Palmdale.

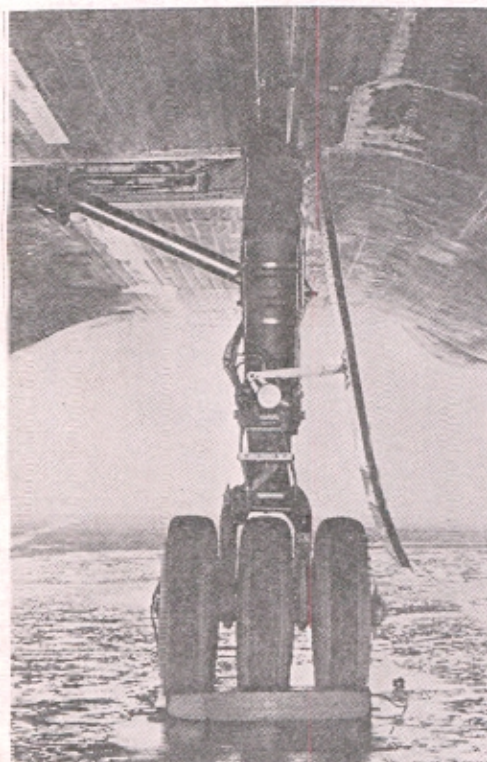

Front of left main gear. Note door angle and scuffed tires. Scuffed look is normal on SR-71 and does not indicate bad tires.

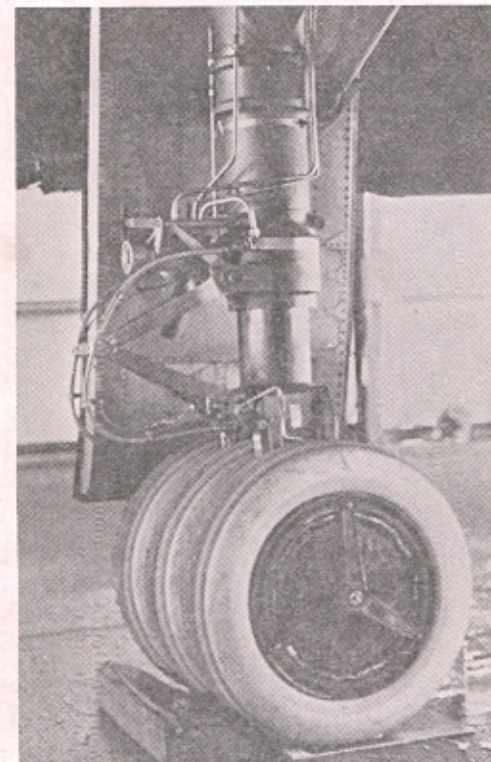

Inside of right main gear. Note silver "dust" look of tires. Hubs are an oxidized rust color from braking heat. Note hose lines.

This kit is dedicated to U.S. Air Force and civilian Lockheed maintenance personnel who keep a maintenance-intensive and aging reconnaissance system flying; to the flight crews - teams of two - who fly the ultimate in precision aircraft operation and navigation; to the American people - the true owners of the aircraft - who continue to give tax support to the program; to Clarence L. (Kelly) Johnson who, over many years, developed a design team and method at the Lockheed Skunk Works that has a tradition of producing aerodynamic miracles; to Ben Rich at Lockheed whose design skill in thermodynamics and powerplant/airframe integration brought a breakthrough in nacelle design that is the key to Blackbird performance; to the Central Intelligence Agency for funding the precedent setting A-12 effort - in 1959 a true technological gamble; to the men of the early flight test crew who pioneered in a speed regime with unknown problems - Lou Schalk, Jim Eastham, Bob Gilliland, Bill Park . . . to name a few; to Pratt & Whitney whose fantastic J-58 engines get Mach 3+ turned on; to Minneapolis Honeywell for automatic on-board systems that ease pilot workload; to the many small firms who built parts of excellence when they didn't know what they were being built for; to the many gutsy foreign nations who share a desire for freedom and allow the airplane to operate from their soil; and, lest we forget, we dedicate this kit to the young people who build this model and in the process learn and touch history, develop an appreciation of American technical competence and, perhaps, are turned on to careers in aerospace. Last, but not least, to the Russian government who, by refusing to consider the 1950's Open Skies Proposal offered by then U.S. President Dwight Eisenhower, made the need for the U-2 A-12, and SR-71 an absolute necessity and thereby guaranteed their production. 0798

MONTAGEM DE KITS PLÁSTICOS ADVERTÊNCIA

- Pode conter peças muito pequenas.
- Não estão incluídas colas e tintas.
- Não é um brinquedo. Não é indicado para crianças menores de 10 anos.
- Leia as instruções antes de começar a montagem.
- Como você estará utilizando colas e tintas, lembre-se de trabalhar em local bem ventilado. Esses produtos produzem vapores perigosos à saúde.

INSTRUÇÕES DE MONTAGEM

MANUSEIO DE PEÇAS:

- Cada peça é identificada individualmente por um número/letra.
- Estude atentamente e siga a sequência de montagem seguindo as ilustrações.
- Antes de começar laves as peças com água morna e detergente, retirando assim resíduos de óleo. Seque-as evitando tocá-las com os dedos. As peças muito pequenas são mais facilmente pintadas quando mantidas na árvore. Use uma pinça para segurá-las.
- Devido a grande quantidade de peças não as destaque da árvore até que tenha que usá-las. Evitando assim confusões e possíveis perdas.
- Para remover as peças da árvore, utilize um pequeno alicate de corte de bico fino ou estilete.
- Algumas peças necessitam ser lixadas para melhorar o acabamento ou seu encaixe.

APLICAÇÃO DE COLAS:

- Use pouca quantidade de cola.
- Cheque o encaixe de cada peça antes de colar. Evite surpresas.
- Você pode usar colas líquidas ou de bastão. As colas de bastão oferecem vários tipos de pontas. As pontas podem ser afiadas. Imediatamente após o uso tampe-as de novo. Pressione a ponta para provocar a saída da cola. Teste inicialmente o fluxo de cola num pedaço de papel.
- As peças transparentes devem ser coladas com cola branca ou colas especiais para tal fim.
- Colas não aderem bem sobre tintas. Retire a tinta onde deverá ser aplicada cola.

PINTURA:

- As peças podem ser pintadas para que seu modelo se torne mais autêntico.
- Misture a tinta antes de usá-la. Retire da embalagem apenas a quantidade que vai utilizar. Mantenha a tampa fechada.
- Esmaltes (enamel): dilua gradualmente a tinta escolhida com thinner. Vá testando a consistência passo a passo. Deixe as peças pintadas secar por 3 a 4 horas antes de tocá-las. Lixe ou raspe a tinta aplicada nas superfícies que serão coladas.
- A fidelidade e a exatidão do seu modelo dependerá da documentação e ilustrações que você poderá obter.
- Bons pincéis são essenciais para se obter um bom acabamento. Tenha disponíveis todos os tipos que você irá precisar. Limpe-os com thinner e após lave-os com água e sabão. Mantenha-os sempre guardados com os pelos para cima.
- Pinte sempre na mesma direção. Usando pincéis da espessura correta, as marcas dos pelos desaparecerão assim que a tinta secar.
- Rodas podem ser destacadas da árvore. Coloque um palito de dentes como eixo e para pintá-las gire-as segurando pelo eixo.

APLICAÇÃO DE DECAIS:

- Aplique os decais apenas após ter certeza da tinta estar totalmente seca.
- Selecione o decal que você pretende utilizar e destaque-o da folha com uma tesoura. Trabalhe com apenas um decal de cada vez. Mergulhe-o em água limpa por não mais de 5 segundos. Retire-o da água e coloque-o sobre uma toalha de papel seca por um minuto. Assim que você perceber que o decal desliza facilmente sobre o papel suporte, arraste-o para a borda e aplique-o sobre o local indicado, usando uma pinça ou pinçal. Lembre-se que o decal é muito fino e pode ser rasgado com facilidade. Manuseie-o com todo cuidado. Use um pincel para que o decal se adapte as formas da superfície onde foi aplicado. Deixe-o secar sem tocá-lo.

Importado e Distribuído no Brasil por

